

Charles Retrofit Kit

97-002494-A

General Description and Installation

1. GENERAL INTRODUCTION	1
1.1. Document Purpose	1
1.2. Product Purpose.....	1
2. INSTALLATION	2
2.1. Inspecting the Product.....	2
2.2. Following and Using Safety Precautions.....	2
2.3. Obtaining Tools and Equipment.....	2
2.4. Mounting the Kit.....	2
3. TECHNICAL ASSISTANCE AND REPAIR SERVICE	10
4. WARRANTY & CUSTOMER SERVICE	10
5. SPECIFICATIONS.....	10

1. GENERAL INTRODUCTION

1.1. Document Purpose

This document provides general information for the 97-002494-A retrofit kit for the Charles Industries SH60-702018 radio shroud. Figure 1 shows the kit components. Mounting hardware is not shown.

-NOTE-

Hereafter, the Charles 97-002494-A retrofit kit will be referred to as the "kit." The SH60-702018 radio shroud will be referred to as the "SHRD60."

1.2. Product Purpose

The kit consists of a set of brackets to be installed in the SHRD60. The brackets support (1) Ericsson 8863 radio, (1) Ericsson 4455 radio, (1) Ericsson 6304 power supply, (2) CommScope CBC1726T-4310 diplexers, and (1) Nokia POD-8 multiplexer. All equipment is customer supplied.

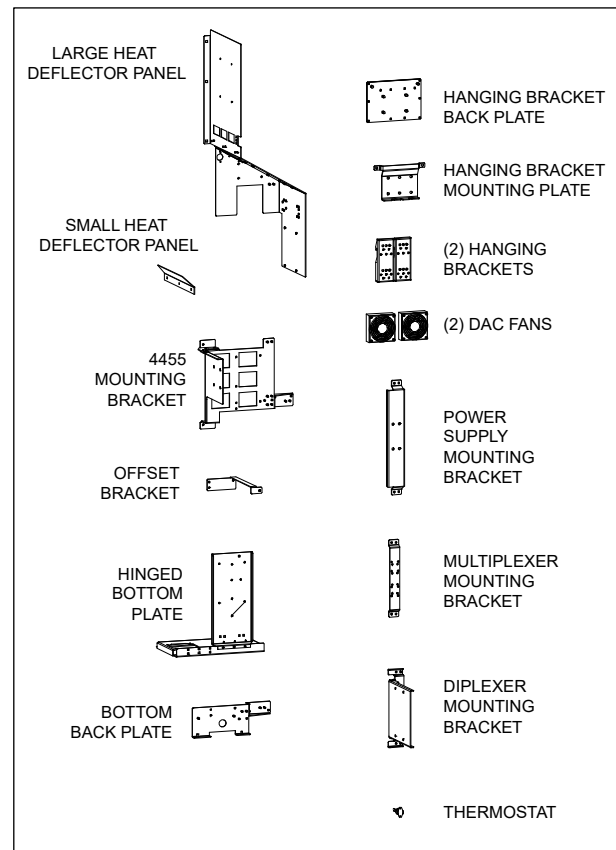

Figure 1 Kit Components

2. INSTALLATION

2.1. Inspecting the Product

The kit is shipped in a carton. Unpack the unit and dispose of the packaging material.

-INSPECTION NOTE-

Visually inspect the unit for damages prior to installation. If the equipment was damaged in transit, immediately report the extent of the damage to the transportation company.

2.2. Following and Using Safety Precautions

Read the following site and safety tips, cautions, and warnings, then proceed with the paragraphs that follow.

- Read all instructions, warnings and cautions on the equipment and in the documentation shipped with the product.
- Do not place this product on weak or unstable surfaces which may allow the product to fall, resulting in potentially serious damage(s) to persons or product.
- Only authorized trained personnel shall install the kit.
- In windy conditions, be sure to engage the wind latch to secure the door in a stationary position.

2.3. Obtaining Tools and Equipment

Obtain the following recommended or needed items for installing the kit.

- Protective and/or insulated work gloves
- Safety glasses
- Can wrench (216 type tool)
- Tape measure
- Marking utensil
- Drill with 5/16" bit
- Hex screwdriver
- Torque wrench
- Level

2.4. Mounting the Kit

In all images in this section, the SHRD60 door is hidden for clarity.

Prior to mounting the kit, remove all radio equipment and brackets from the SHRD60.

Figure 2 shows the SHRD60 prepared for the kit installation.

Hardware for mounting the kit brackets into the SHRD60 is supplied with the kit. Hardware for mounting the radio equipment is customer supplied.

2.4.1. Torque Requirements

Torque all hardware as shown below (unless otherwise noted). These values apply to SAE Grade 1 & 2 Low Carbon Steel, ASTM A307 Low Carbon Steel, and Stainless Steel Grade 18-8.

Thread Size	In-lbs	Ft-lbs
4-40	4±10%	
6-32	8±10%	
8-32	16±10%	
10-32	26±10%	
12-24	50±10%	
1/4-20/M6	60±5%	5±5%
5/16-18	125±5%	10.4±5%
3/8-16	180±5%	15.0±5%
1/2-13	500±2%	41.7±2%
5/8-11	1000±1%	83.3±1%

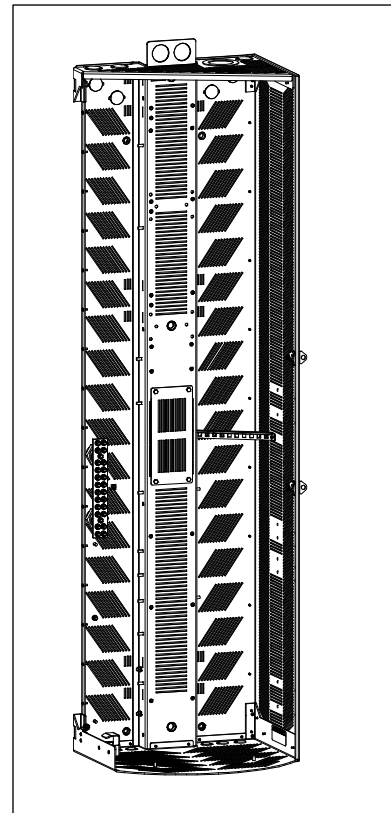

Figure 2 Empty SHRD60

2.4.2. Remove Ground Bar

The new configuration requires moving the ground bar to a new location. At this time, remove the ground bar and set aside, saving the mounting hardware for later installation (Figure 3).

2.4.3. Bottom Back Plate

1. Place the bottom back plate against the central spine. The bottom flange of the back plate rests on the bottom of the SHRD60, and the right edge of the plate is against the right side of the SHRD60 frame. There are several studs on the SHRD60 rear panel that align with holes in the bottom back plate to ensure correct positioning.
2. Mark the locations of the three holes indicated in Figure 4
3. Use a 5/16" drill bit to drill holes at the marked locations. Use touch-up paint on the insides of these holes to prevent corrosion.
4. Secure the bottom back plate in position using 1/4-20 hex screws with lock washers and flat washers through the front and 1/4-20 Keps nuts on the rear of the SHRD60.

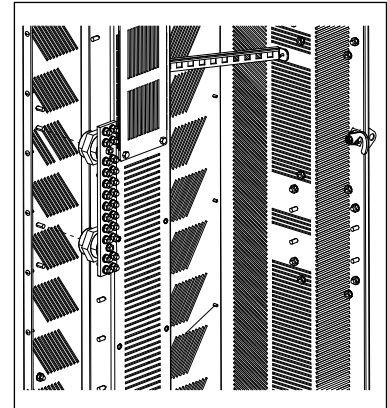

Figure 3 Remove Ground Bar

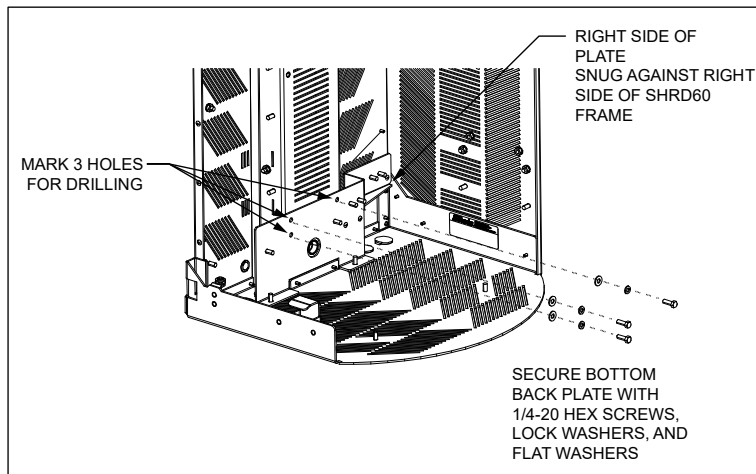

Figure 4 Mount Diplexers

2.4.4. Hinged Bottom Plate

Secure the hinged bottom plate to the SHRD60 bottom plate using four existing studs. Use four 1/4-20 Keps nuts (Figure 5). At this time, the hinged leg should remain in its downward position. Use care not to step on or otherwise damage this leg.

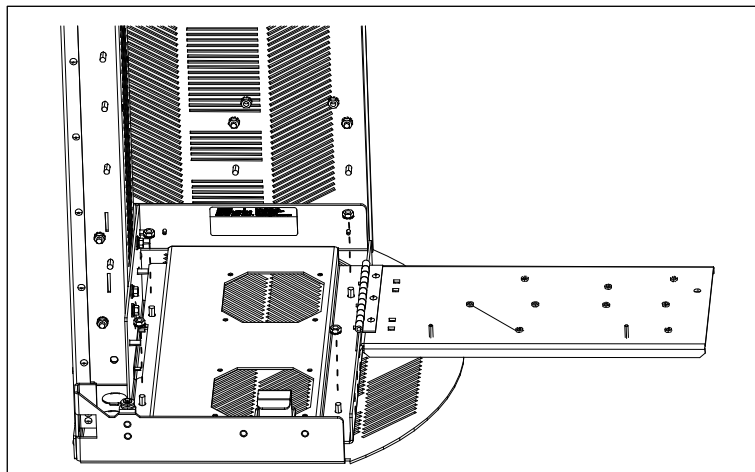

Figure 5 Hinged Bottom Plate

2.4.5. 4455 Mounting Bracket

1. Position the 4455 mounting bracket as shown in Figure 6 (12.50" from the bottom of the SHRD60, 2.20" from the left side flange).
2. Mark the locations of the three holes indicated in Figure 6
3. Use a 5/16" drill bit to drill holes at the marked locations. Use touch-up paint on the insides of these holes to prevent corrosion.
4. Install the 4455 mounting bracket using 1/4-20 hex screws with lock washers and flat washers through the front and 1/4-20 Keps nuts on the rear of the SHRD60.

2.4.6. Ground Bar

Mount the ground bar on the bottom back plate using the hardware removed previously (Figure 7).

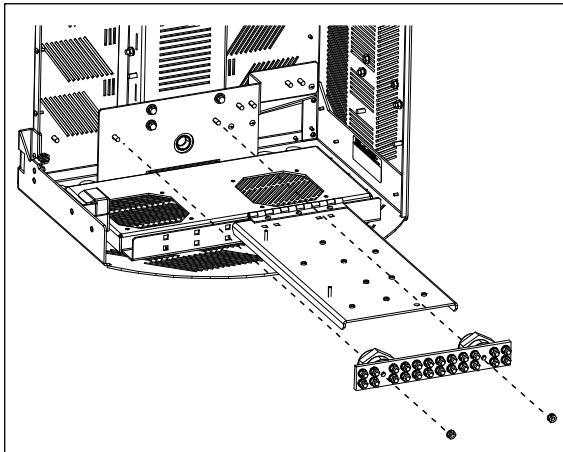

Figure 7 Replace Ground Bar

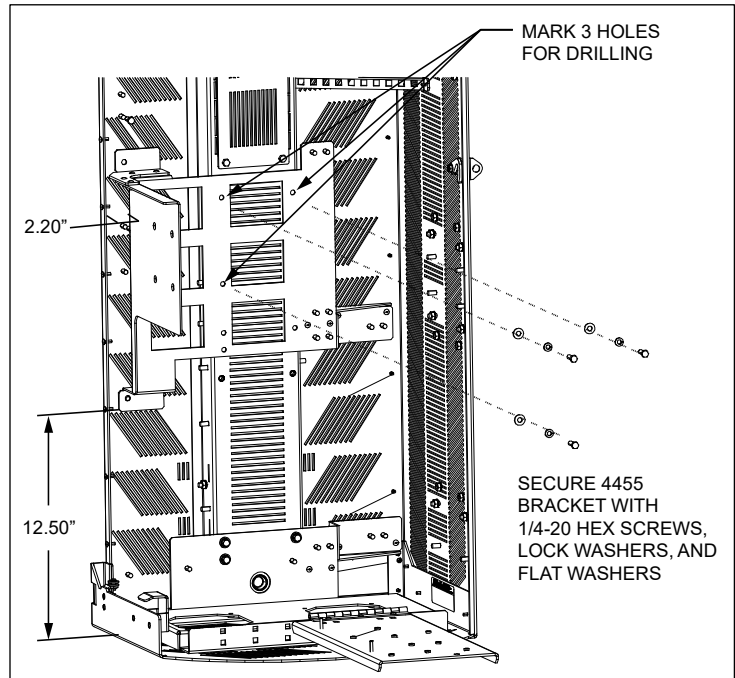

Figure 6 4455 Mounting Bracket

2.4.7. Offset Bracket

Install the offset bracket onto the available holes in the 4455 mounting bracket.

1. If there are no corresponding holes in the SHRD60 central spine, then use a drill with a 5/16" bit to create these holes.
2. Use touch-up paint on the insides of these holes to prevent corrosion.
3. Install the offset bracket using 1/4-20 hex screws with lock washers and flat washers through the front and 1/4-20 Keps nuts on the rear of the SHRD60.

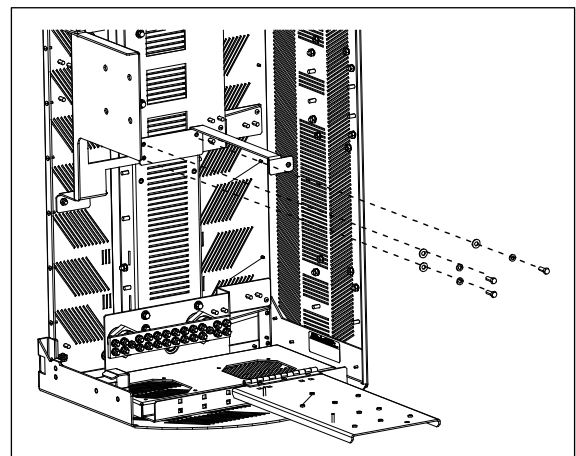

Figure 8 Offset Bracket

2.4.8. Fans

The kit includes two direct air cooling (DAC) fans with finger guards. Install the fans on the bottom plate using the long screws provided (four screws per fan, Figure 9).

2.4.9. Lower Diplexer

Attach one of the diplexers to the diplexer mounting bracket as shown in Figure 10.

Install this diplexer/bracket assembly onto the studs as shown in Figure 11 (rightmost set of studs, two studs on the 4455 bracket, two studs on the bottom back plate). Secure using four 1/4-20 Keps nuts.

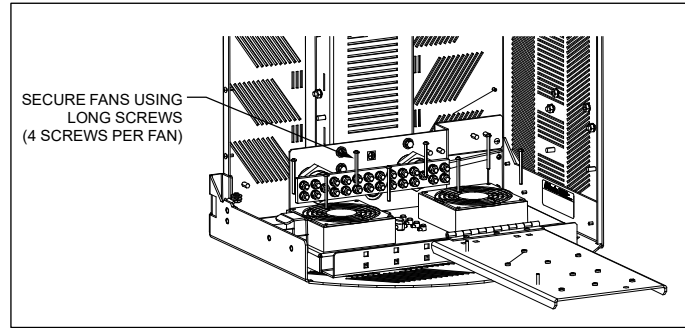

Figure 9 DAC Fans

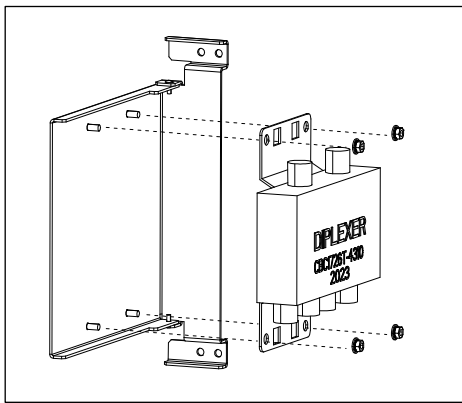

Figure 10 Attach Diplexer to Diplexer Mounting Bracket

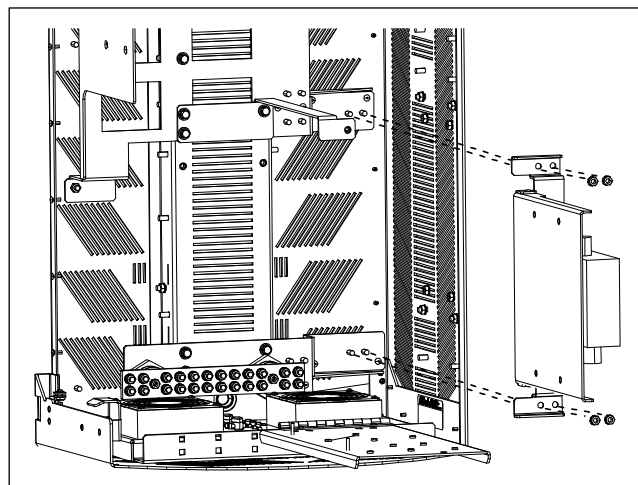

Figure 11 Install Lower Diplexer

2.4.10. Multiplexer

Attach the multiplexer to the multiplexer mounting bracket. Then install this assembly onto the studs as shown in Figure 12 (next set of studs to the left of the diplexer bracket, two studs on the 4455 bracket, two studs on the bottom back plate). Secure using four 1/4-20 Keps nuts.

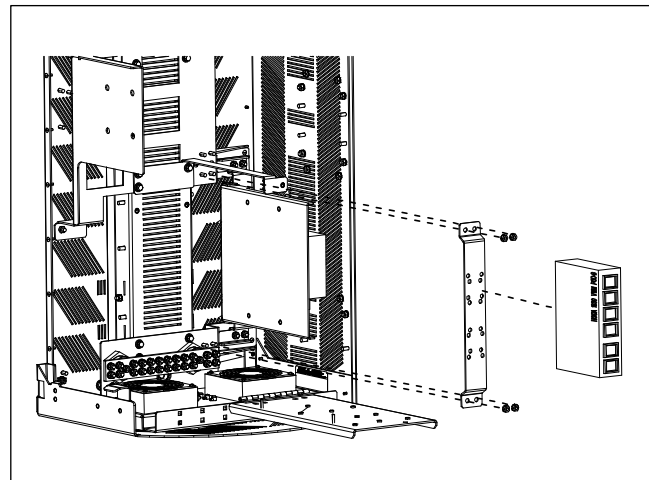

Figure 12 Install Multiplexer

2.4.11. Secure Hinged Leg

Pivot the hinged leg of the bottom plate into its vertical position. Secure in place using one 1/4-20 hex screw, lock washer, and flat washer (Figure 13).

2.4.12. Large Heat Deflector Panel

1. Position the large heat deflector panel as shown in Figure 14.
 - The large cutout on the lower half of the panel fits around the removable cover panel on the SHRD60 central spine.
 - The rightmost vertical leg on the panel also has a small cutout. Position this cutout so it sits on top of the diagonal strengthening bar in the SHRD60.
2. Mark the locations of the six holes indicated in Figure 14
3. Use a 5/16" drill bit to drill holes at the marked locations. Use touch-up paint on the insides of these holes to prevent corrosion.
4. Install the large deflector panel using 1/4-20 hex screws with lock washers and flat washers through the front and 1/4-20 Keps nuts on the rear of the SHRD60.

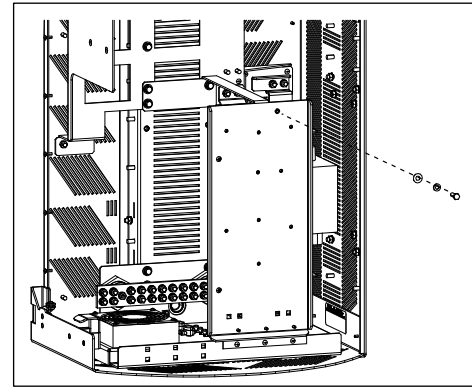

Figure 13 Secure Hinged Leg

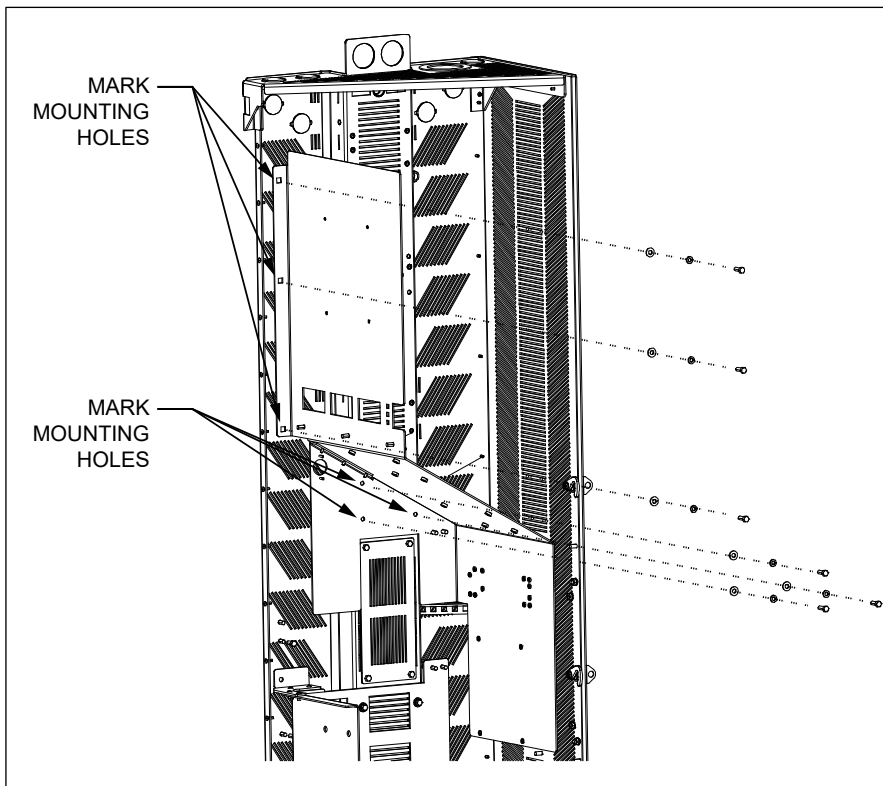

Figure 14 Install Large Heat Deflector Panel

2.4.13. Power Supply

Attach the power supply to the power supply mounting bracket. Then install this assembly onto the studs as shown in Figure 15. The upper holes on the bracket use the studs on the bottom of the deflector panel, and the lower holes use the studs on the 4455 bracket. Secure using four 1/4-20 Keps nuts.

2.4.14. 4455 Radio

Install the 4455 radio on the right side of the front-facing leg on the 4455 bracket. Secure from behind the leg with customer supplied hardware (Figure 16).

2.4.15. Thermostat

1. Locate the large circular hole underneath the angled section of the large heat deflector panel.
2. Drill out the section of the SHRD60 rear panel behind this hole. Use touch-up paint on this hole to prevent corrosion.
3. Install the thermostat onto the studs above and below this hole using two 1/4-20 Keps nuts (Figure 17).

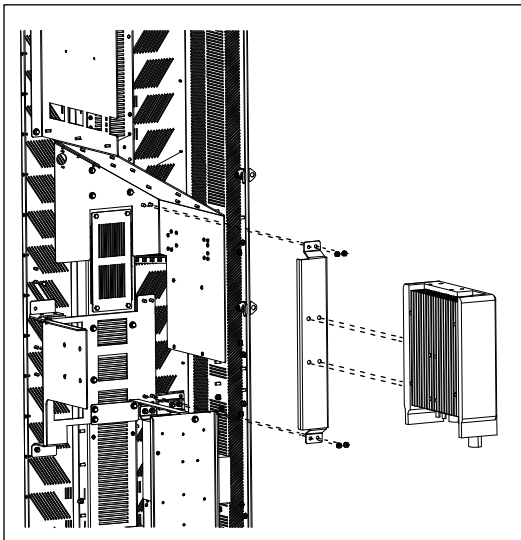

Figure 15 Install Power Supply

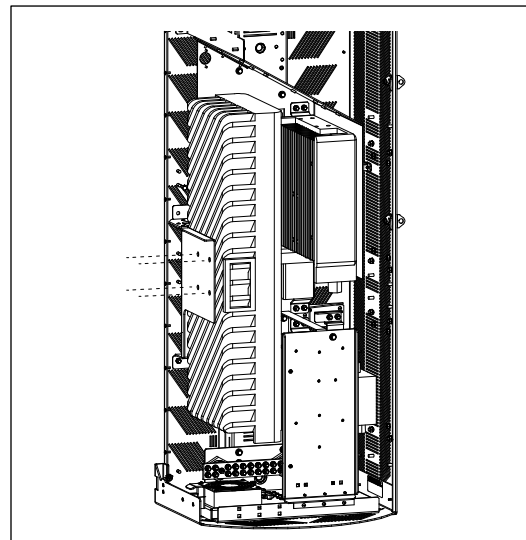

Figure 16 Install 4455 Radio

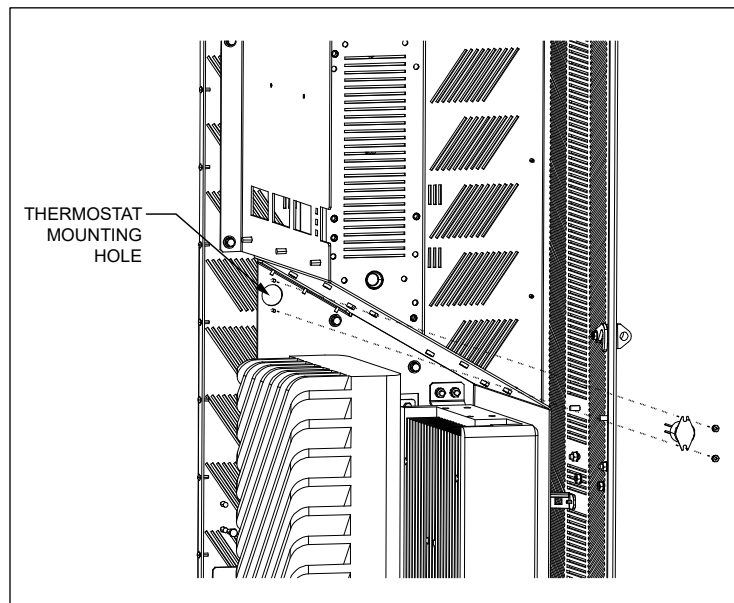

Figure 17 Install Thermostat

2.4.16. Small Heat Deflector Panel

Install the small deflector panel on the leftmost section of the large deflector panel (Figure 18). Secure using three 1/4-20 Keps nuts.

2.4.17. Upper Diplexer

Install the remaining diplexer on the angled section of the large heat deflector panel. Secure using four 1/4-20 hex screws with flat washers (Figure 19).

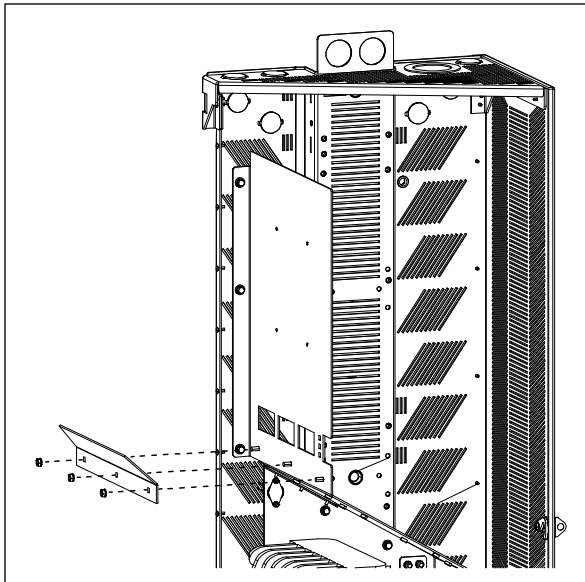

Figure 18 Install Small Heat Deflector Panel

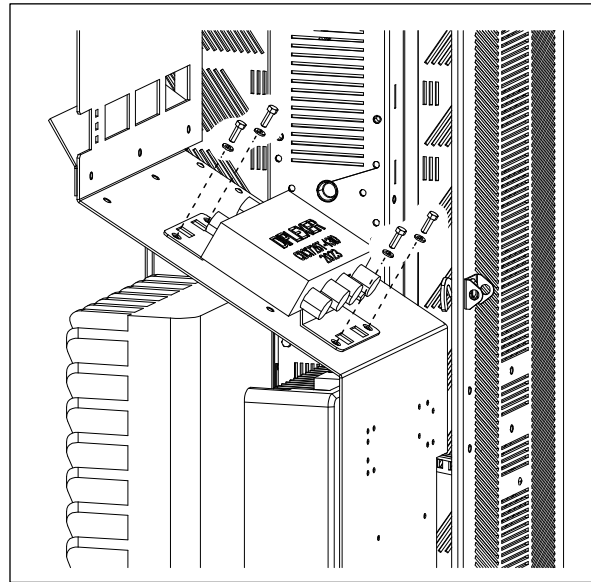

Figure 19 Install Upper Diplexer

2.4.18. Hanging Bracket and 8863 Radio

The hanging bracket assembly has four components: the back plate, the mounting plate, and the two hanging brackets.

1. Place the back plate against the central spine, aligning the upper left mounting hole with the hole in the SHRD60 central spine (approx. 14" from the top of the SHRD60).
2. Ensure that the back plate is level. Mark the locations of the four mounting holes indicated in Figure 20. Set the back plate aside.
3. Use a 5/16" drill bit to drill holes at the marked locations. Use touch-up paint on the insides of these holes to prevent corrosion.
4. Install the back plate using 1/4-20 hex screws with lock washers and flat washers through the front and 1/4-20 Keps nuts on the rear of the SHRD60.

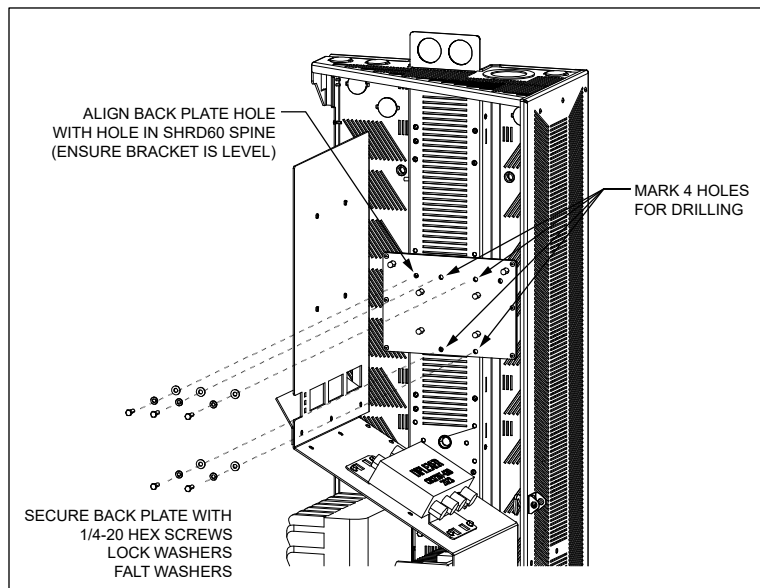

Figure 20 Hanging Bracket Back Plate

5. Attach the mounting plate to the studs on the back plate using five 1/4-20 Keps nuts (Figure 21).
6. Attach the two hanging brackets to the back of the 8863 radio using customer supplied hardware.
7. Hang the hanging brackets from the mounting plate. Secure the brackets in place by tightening the 10-32 screws on the bottom of each hanging bracket (Figure 22).

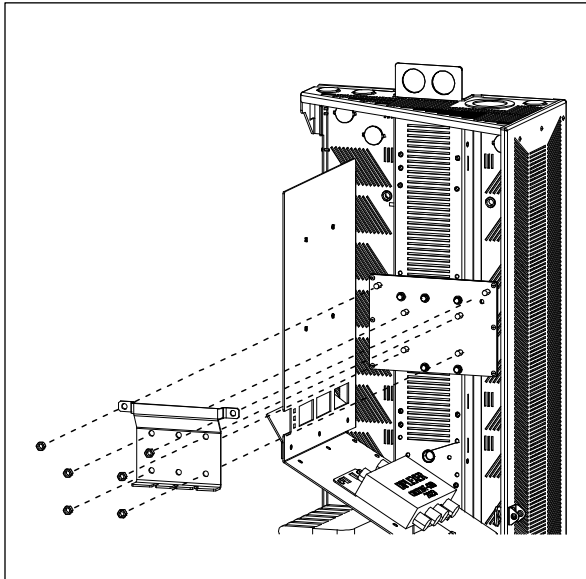

Figure 21 Hanging Bracket Mounting Plate

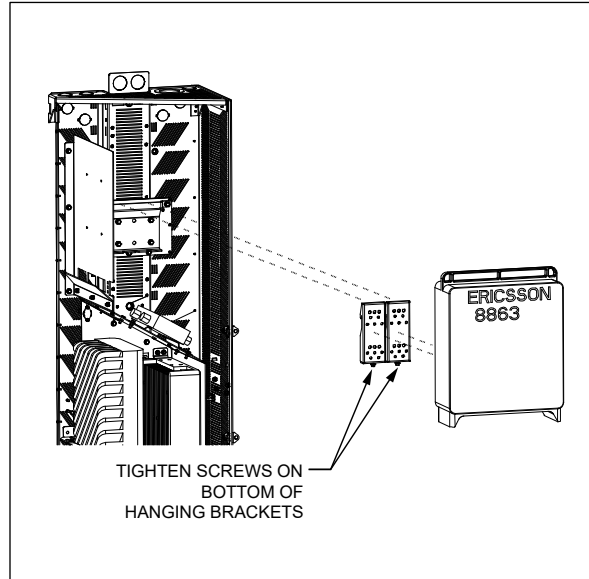

Figure 22 Install 8863 Radio

2.4.19. Wiring the Fans

Wire the fans to a customer supplied 48VDC power system as shown in Figure 23. The Scotchlok connectors are included with the kit.

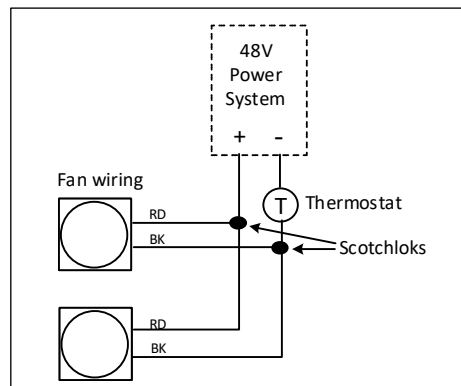

Figure 23 Fan Wiring

2.4.20. Complete the Installation

The complete kit installation is shown in Figure 24.

3. TECHNICAL ASSISTANCE AND REPAIR SERVICE

For questions on product repair or if technical assistance is required, contact Charles Technical Support.

847-806-8500
 (email)
<http://www.charlesindustries.com/techserv.htm>

4. WARRANTY & CUSTOMER SERVICE

Charles Industries LLC offers a one-year warranty on the kit product. The Charles warranty is limited to the operation of the kit hardware as described in this documentation and does not cover equipment that may be integrated by a third party. The terms and conditions applicable to any specific sale of product shall be defined in the resulting sales contract. For questions on warranty or other customer service assistance, contact your Charles Customer Service Representative.

847-806-6300
mktserv@charlesindustries.com (email)

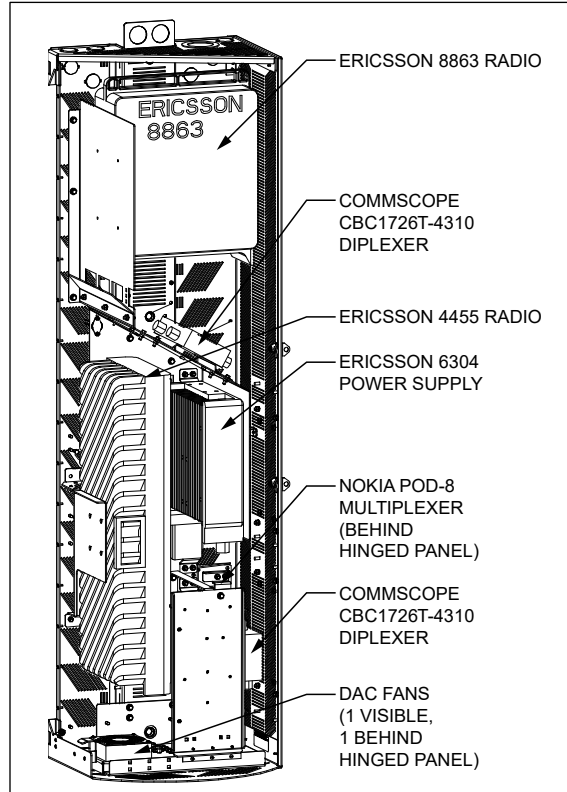

Figure 24 Complete Installation

http://www.charlesindustries.com/main/telecom_sales_support.htm

5. SPECIFICATIONS

Physical	
Weight	Approx. 60 lbs. as shipped
Materials	Steel
Color	Off-white
Touch-up Paint	02-000290-0
216 Type Security Tool	07-002070-0

Table 1 Kit Specifications