

Charles Universal Broadband Enclosure

CUBE-RL1003FA-A

General Description and Installation

1. GENERAL INTRODUCTION	1
1.1. Document Purpose	1
1.2. Product Purpose	1
1.3. Product Mounting and Location	1
2. PRODUCT DESCRIPTION	2
3. INSTALLATION	4
3.1. Inspecting the Product	4
3.2. Following and Using Safety Precautions	4
3.3. Obtaining Tools and Equipment	4
3.4. Preparing the Installation Site	4
3.5. Lifting the CUBE	5
3.6. Mounting the CUBE	5
3.7. CUBE Wiring and Equipment	5
3.8. Conduit Seals	6
3.9. Verifying the Installation	6
4. PERIODIC MAINTENANCE	7
5. TECHNICAL ASSISTANCE AND REPAIR SERVICE	7
6. WARRANTY & CUSTOMER SERVICE	7
7. SPECIFICATIONS	7

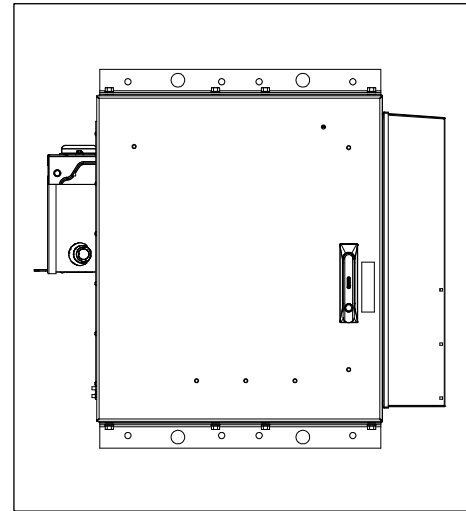

Figure 1 Front View of the CUBE

1. GENERAL INTRODUCTION

1.1. Document Purpose

This document provides general information for the CUBE-RL1003FA-A of the Charles Industries' Universal Broadband Enclosure (CUBE) product line. Figure 1 shows a closed front view of the enclosure.

-NOTE-

Hereafter, the Charles Universal Broadband Enclosure CUBE-RL1003FA-A will be referred to as the "CUBE."

1.2. Product Purpose

The CUBE consists of a protective enclosure for an integrated system of electronic components and equipment that can serve fiber and copper interfaces.

1.3. Product Mounting and Location

This enclosure is suitable for outside plant-type (OSP) locations and those that may require NEC compliance. The outdoor, weather-resistant CUBE is to be mounted on a wall. The installer connects the power, fiber, and copper connections. Detailed mounting and installation information is covered in Section 3.

2. PRODUCT DESCRIPTION

The CUBE consists of a single compartment with 13RU of 19" horizontal rack space, a 4-position AC load center, a 750W heat exchanger, and a 10-position fuse panel.

Figure 2 shows the CUBE dimensions. Figure 3 shows the main components of the CUBE.

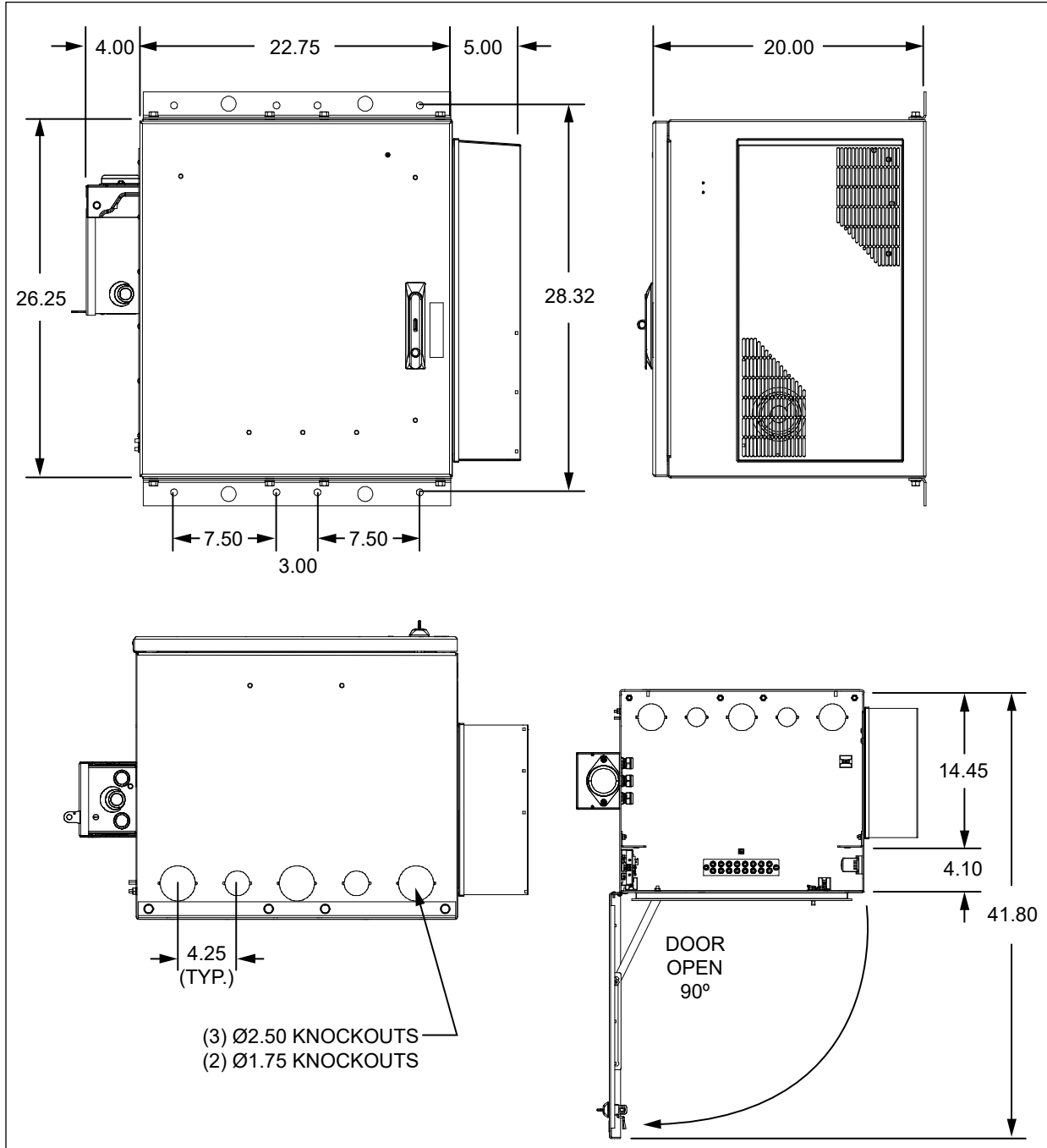

Figure 2 CUBE Dimensions (in inches)

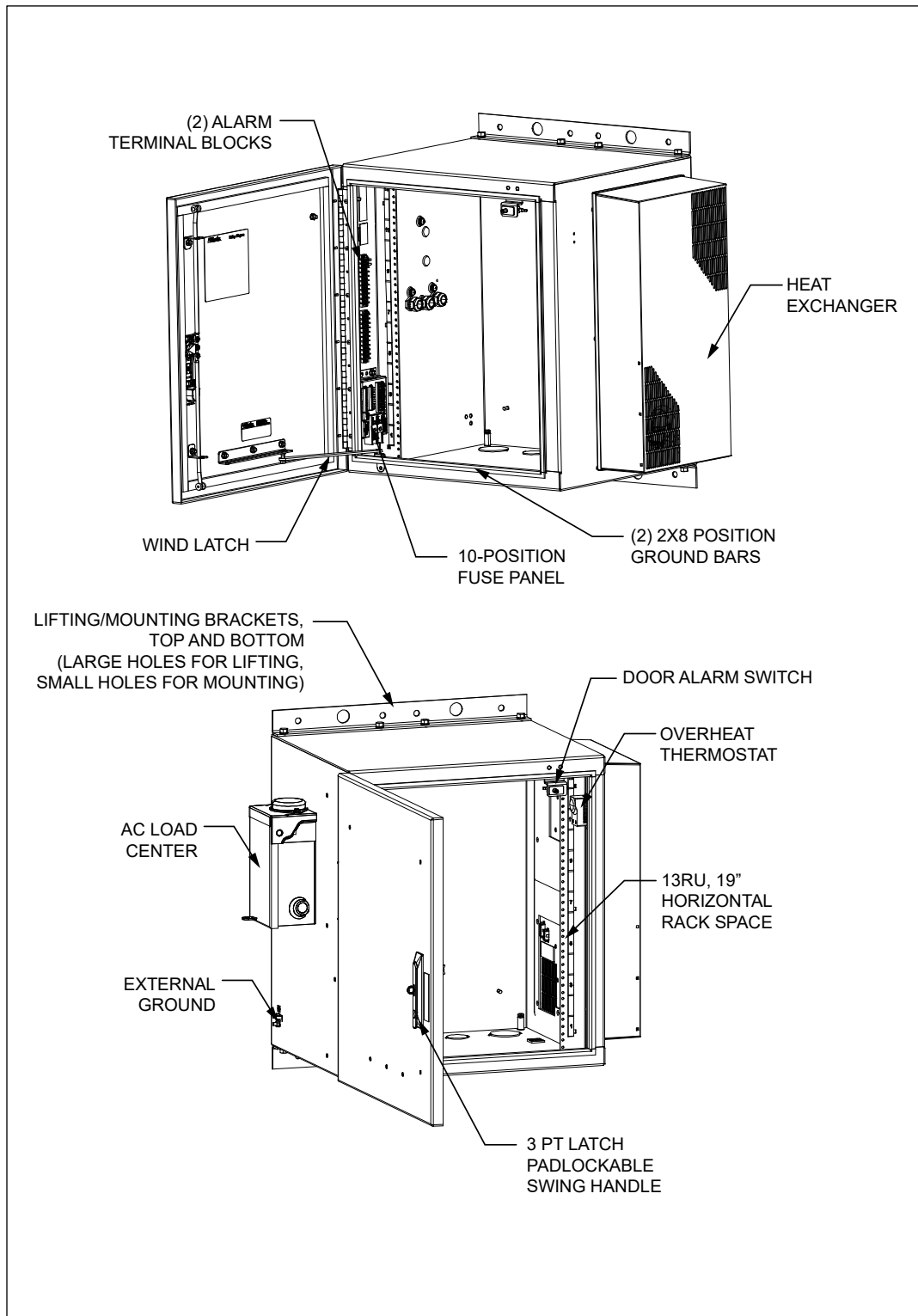

Figure 3 CUBE Components

3. INSTALLATION

3.1. Inspecting the Product

The CUBE is shipped mounted upright on a skid. Remove the bolts, unpack the unit, and dispose of the packaging material.

-INSPECTION NOTE-

Visually inspect the unit for damages prior to installation. If the equipment was damaged in transit, immediately report the extent of the damage to the transportation company.

3.2. Following and Using Safety Precautions

Read the following site and safety tips, cautions, and warnings, then proceed with the paragraphs that follow.

- For installation, follow all National Electrical Codes (NEC) ANSI/NFPA 70, local, environmental, workplace, and company codes, safety procedures, and practices.
- Minimum spacing between the accessories and components and the housing for ITE equipment shall be maintained for safe operation of the equipment when installed in accordance with NEC ANSI/NFPA 70.
- Read all instructions, warnings and cautions on the equipment and in the documentation shipped with the product.
- Always connect ground connections first.
- Do not place this product on weak or unstable surfaces which may allow the product to fall, resulting in potentially serious damage(s) to persons or product.
- Only authorized trained personnel shall install the CUBE.
- In windy conditions, be sure to engage the door latches to secure the door in a stationary position.

3.3. Obtaining Tools and Equipment

Obtain the following recommended or needed items for installing the CUBE.

- Sufficient length and quantities of fiber cable (or pigtails)
- Cable scoring, opening, and cutting tools for cable sheathing, shields, wrappings, strength members and buffer tubes
- Wire strippers
- Crimpers
- Cable, tube, wire, and fiber cleaning materials
- Protective and/or insulated work gloves
- Safety glasses
- Tape measure
- Marking utensil
- #6 ground wire or rod and earth ground materials
- Bond strap (optional, from cable bond clamp to bond post)
- Any exterior cable strain relief, per company practice
- Slotted, hex, and Phillips screwdrivers
- Torque wrench
- Assorted cable ties, clips, or fasteners (optional)
- Can wrench (216 type tool)
- Derrick for lifting
- Level

3.4. Preparing the Installation Site

Observe the following site preparation recommendations.

- Leave adequate horizontal and vertical space between multiple installations to allow for proper cable access, as well as enough room around the enclosure to open the door(s).
- The site must meet minimal personnel and equipment safety requirements.
- The distance from the cable entry point should be consistent with local installation practices.
- The wall must be able to support the weight of the CUBE.
- Run all fiber and copper facilities to the site.

3.5. Lifting the CUBE

See Table 1 for CUBE weight. Use appropriate lifting equipment (hand truck or dolly) to move the CUBE into position.

3.6. Mounting the CUBE

Mount the CUBE on a wall. Refer to Figure 2 for dimensions for positioning mounting hardware. Charles recommends using a minimum SAE Grade 2, corrosion-resistant 3/8" diameter bolts, washers and nuts. Bolts need to be of sufficient length depending on the wall. A minimum of 3/4" thick plywood or similar surface is required. Ensure that the unit is level.

3.6.1. Torque Requirements

Torque all hardware as shown below (unless otherwise noted). These values apply to SAE Grade 1 & 2 Low Carbon Steel, ASTM A307 Low Carbon Steel, and Stainless Steel Grade 18-8.

Thread Size	In-lbs	Ft-lbs
4-40	4±10%	
6-32	8±10%	
8-32	16±10%	
10-32	26±10%	
12-24	50±10%	
1/4-20/M6	60±5%	5±5%
5/16-18	125±5%	10.4±5%
3/8-16	180±5%	15.0±5%
1/2-13	500±2%	41.7±2%
5/8-11	1000±1%	83.3±1%

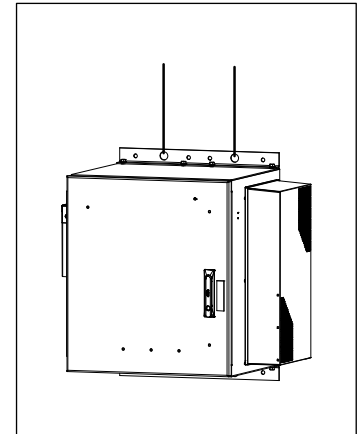

Figure 4 Lifting the CUBE

3.7. CUBE Wiring and Equipment

After the CUBE is properly mounted in the desired location, apply No-Ox where bus bar and other 2-hole lug connections will be made. Install ground and power connections. Always ground the equipment first, before making any other connections.

	WARNING	Perform all bonding and grounding connections prior to any electrical and communications connections.
--	----------------	--

In order to prevent condensation prior to being placed in service, do not remove the desiccant until the CUBE is sealed and power is applied. A basic electrical diagram is shown in Figure 5.

3.7.1. Ground Connection

Use the two 2x8 position ground bars provided in the CUBE for all grounding of internal equipment. Stack hardware as shown in Figure 6. An external ground lug is available on the side for connecting a site ground wire.

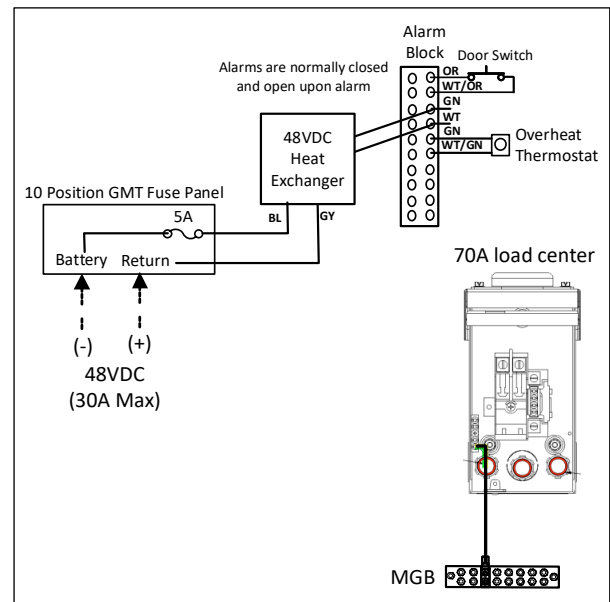

Figure 5 Electrical Diagram

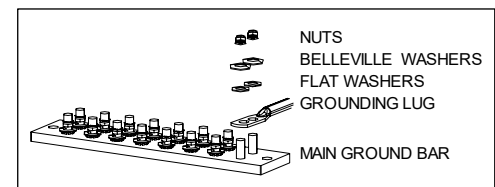

Figure 6 Ground Bar Hardware Stack

3.7.2. Heat Exchanger Operation

The 750W DC powered heat exchanger in the equipment compartment has a fan speed controller and includes an internal and an external fan. Both fans’ speed increases with increasing internal cabinet temperature. Fans and heat exchanger settings are defined below, and are based off of the cabinet interior temperature. The maximum airflow amount supplied to the equipment by the heat exchanger is 147CFM.

Setting	Internal	External
Turn-on Setting (5°C Differential)	0°C	30°C
Medium Temp Setting	30°C	35°C
High Temp Setting	45°C	50°C
High Temp Alarm Setting	70°C	N/A
Low Temp Alarm Setting	-40°C	N/A

For more information, refer to the heat exchanger documentation found inside the CUBE.

-NOTE-

Changing the speed controller default factory set points can lead to system performance issues, such as equipment failures, increased power use, unnecessary alarms, noise, condensation build up, fan failure caused by excessive runtimes and vibration. Avoid placing items in front of the heat exchanger’s return and supply vents. Maintain a minimum of 6” clearance to enable proper air flow.

3.7.3. Overheat Thermostat

The CUBE is equipped with an overheat (high temperature) alarm thermostat in the equipment compartment that provides a normally closed connection. The overheat alarm is factory set at 60°C and opens the connection if this temperature is exceeded.

-NOTE-

Changing the overheat (high-temp) thermostat default factory set points can lead to unnecessary alarms or system performance issues, such as equipment failures as a result of unreported alarms.

3.7.4. Alarm Block Connections

Two 10-position, labeled alarm blocks monitor components in the CUBE. See the electrical diagram for information about alarm connections. All connections are normally closed and will open upon alarm.

3.7.5. Fiber and Copper Entry

The CUBE bottom panel has Ø1.75” and Ø2.50” knockouts that accommodate Ø1.25” and Ø2.00” conduit fittings, respectively. See Figure 2 for knockout locations.

3.8. Conduit Seals

All internal and external conduit openings on the CUBE must be completely sealed with a duct seal compound to prevent moisture from entering the equipment compartment. Use a moldable, flame-retardant putty style duct seal material. Do not use an expanding foam seal. Mold the putty so that the open space around the wire or conduit is completely sealed, as shown in Figure 7. If the openings must be accessed at any time, remove the putty and set it aside. When work is complete, re-mold the putty to re-seal the opening.

3.9. Verifying the Installation

Verify that earth ground and all grounding and bonding is complete and functional. After verifying that all installer connections are secure and complete, apply voltage.

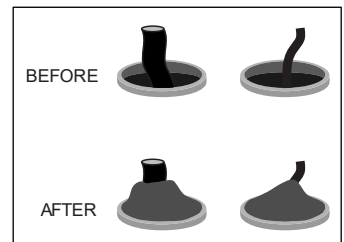

Figure 7 Applying Putty Seal

4. PERIODIC MAINTENANCE

In the event that the enclosure must be opened in freezing conditions, use a narrow, pointed metallic object such as a screwdriver or chisel, along with a non-metallic device like a rubber mallet, to remove excessive ice buildup around the door and locking mechanism. A commercial aerosol de-icer spray can be used to free up locks and latches if needed. Use protective gloves and safety glasses when applying de-icer sprays.

The heat exchanger requires no scheduled maintenance other than cleaning the fans and heat exchanger core if they become contaminated with dust or residue. Remove the cover by removing the screws on the outside. Examine periodically to determine the required cleaning periods based on the installed environmental conditions.

5. TECHNICAL ASSISTANCE AND REPAIR SERVICE

For questions on product repair or if technical assistance is required, contact Charles Technical Support.

847-806-8500
techserv@charlesindustries.com (email)
<http://www.charlesindustries.com/techserv.htm>

6. WARRANTY & CUSTOMER SERVICE

Charles Industries LLC offers a one-year warranty on the CUBE product. The Charles warranty is limited to the operation of the CUBE hardware as described in this documentation and does not cover equipment that may be integrated by a third party. The terms and conditions applicable to any specific sale of product shall be defined in the resulting sales contract. For questions on warranty or other customer service assistance, contact your Charles Customer Service Representative.

847-806-6300
mktserv@charlesindustries.com (email)
http://www.charlesindustries.com/main/telecom_sales_support.htm

7. SPECIFICATIONS

Physical	
Dimensions	26"Hx23"Wx20"D
Weight	Approx. 90 lbs. as shipped
19" Equipment Rack Space and Hole Spacing	22.75" (13RU) rack spacing with tapped EIA #12-24 mounting holes
Maximum Supported Weight	Rack Rails: 143 lbs.
Materials	0.125" aluminum
Color	Off-white
Electrical	
AC Load Center	Square D QO24L 70RB
Fuse Panel	Trimm Inc. 7473121031
Bonding and Grounding	(2) 2x8 position ground bars in CUBE, one external ground
Cable Entry	See Figure 2 and section 3.7.5
Thermal	
Heat Exchanger	750W, 48VDC, Vikinor VHc-030-DC
Maximum Heat Dissipation	710W@19°C above ambient with solar
Environmental	
Operating Temp. Range, Outside Enclosure	-40° to +115°F, -40° to 46°C
Operating Temp Range, Inside Enclosure	-40° to +149°F, -40° to 65°C
Humidity	0 to 95% (non-condensing)
Altitude	Up to 2,000 meters (6560 feet)
Kits and Replacement Parts	
Touch-up Paint	02-000290-0
Swing Handle	39-000148-0
2-Wire Door Alarm Switch	17-400314-0
Overheat Thermostat	99-004548-0

Table 1 CUBE Specifications