

# Charles Universal Broadband Enclosure

## CUBE-PM62422MN3 and CUBE-PM62422MN4

### General Description and Installation

<b>1. GENERAL INTRODUCTION .....</b>	<b>1</b>
1.1. Document Purpose .....	1
1.2. Product Purpose .....	1
1.3. Product Mounting and Location .....	1
<b>2. PRODUCT DESCRIPTION.....</b>	<b>2</b>
<b>3. INSTALLATION .....</b>	<b>4</b>
3.1. Inspecting the Product.....	4
3.2. Following and Using Safety Precautions.....	4
3.3. Obtaining Tools and Equipment.....	4
3.4. Preparing the Installation Site.....	4
3.5. Lifting the CUBE.....	5
3.6. Mounting the CUBE.....	5
3.8. CUBE Wiring and Equipment .....	7
3.9. Conduit Seals.....	11
3.10. Verifying the Installation .....	11
<b>4. PERIODIC MAINTENANCE.....</b>	<b>11</b>
<b>5. TECHNICAL ASSISTANCE AND REPAIR SERVICE .....</b>	<b>11</b>
<b>6. WARRANTY &amp; CUSTOMER SERVICE .....</b>	<b>11</b>
<b>7. SPECIFICATIONS.....</b>	<b>12</b>
7.1. Regulatory Specifications .....	12
7.2. Product Specifications.....	12

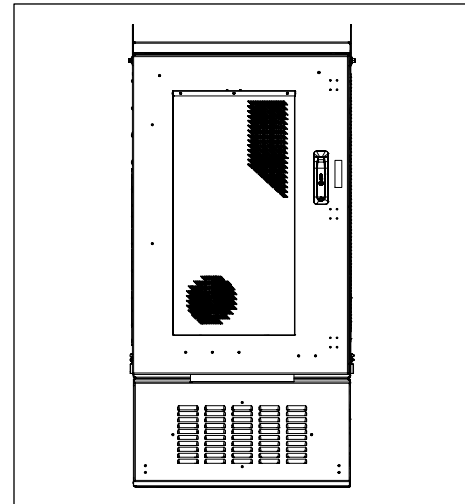

**Figure 1 Front View of the CUBE**

## 1. GENERAL INTRODUCTION

### 1.1. Document Purpose

This document provides general information for the CUBE-PM62422MN3 and CUBE-PM62422MN4 of the Charles Industries' Universal Broadband Enclosure (CUBE) product line. Figure 1 shows a closed front view of the enclosure.

*-NOTE-*  
*Hereafter, the Charles Universal Broadband Enclosure CUBE-PM62422MN3 and CUBE-PM62422MN4 will be referred to as the "CUBE."*

### 1.2. Product Purpose

The CUBE consists of a protective enclosure for an integrated system of electronic components and equipment that can serve fiber and copper interfaces.

### 1.3. Product Mounting and Location

This enclosure is suitable for outside plant-type (OSP) locations and those that may require NEC compliance. The outdoor, weather-resistant CUBE is to be mounted on a pad. The installer connects the power, fiber, and copper connections. Detailed mounting and installation information is covered in Section 3.

## 2. PRODUCT DESCRIPTION

The CUBE has two compartments. The equipment compartment includes 24RU of 23" horizontal rack space, an 1880W DC powered heat exchanger, a 16-position AC load center, and an ABB power shelf with two rectifiers. The MN4 model also includes a 5kBTU HVAC on the rear door. The battery compartment supports one string of 200Ah VRLA customer supplied batteries.

Figure 2 shows the CUBE dimensions. Figure 3 shows the main components of the CUBE.

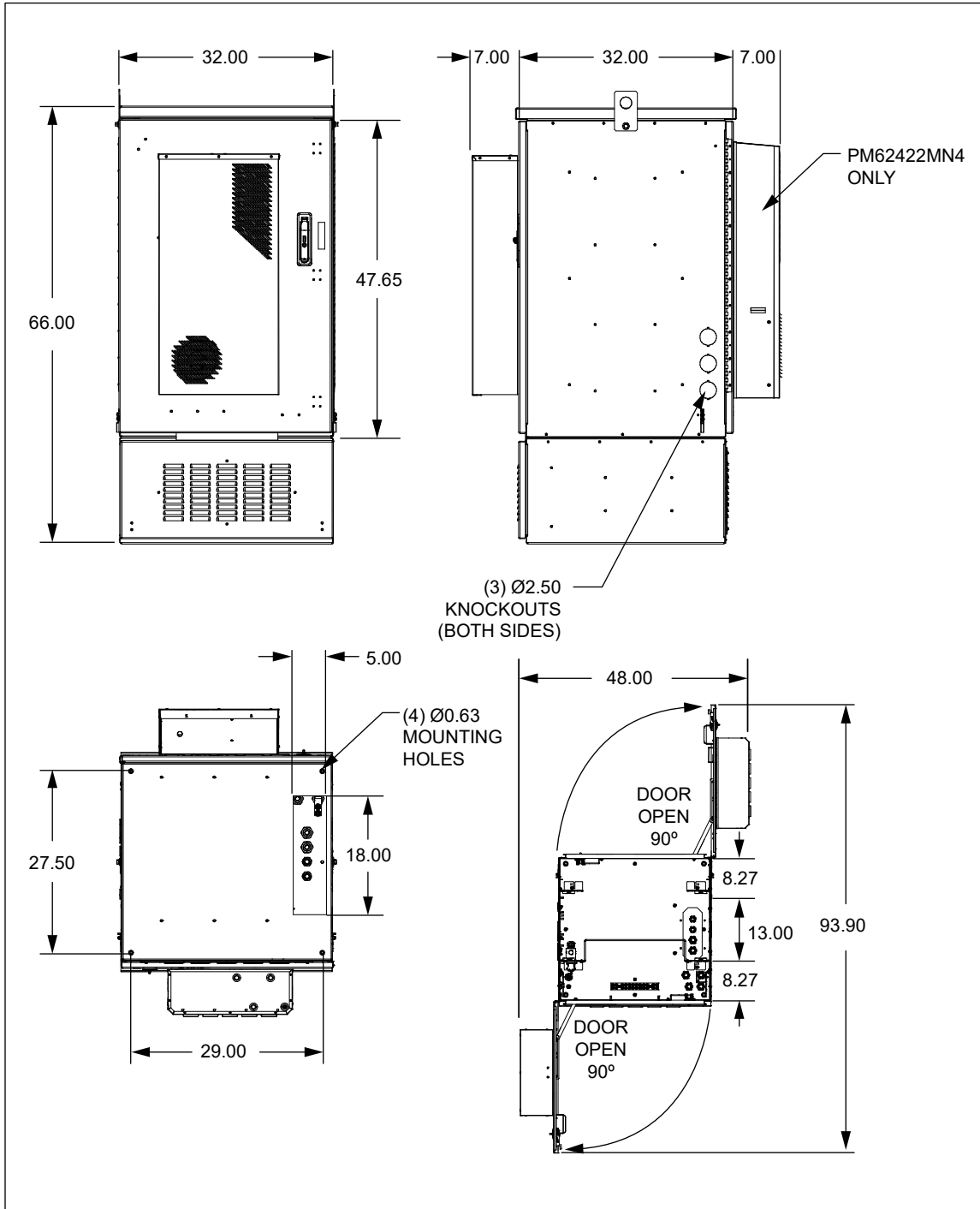
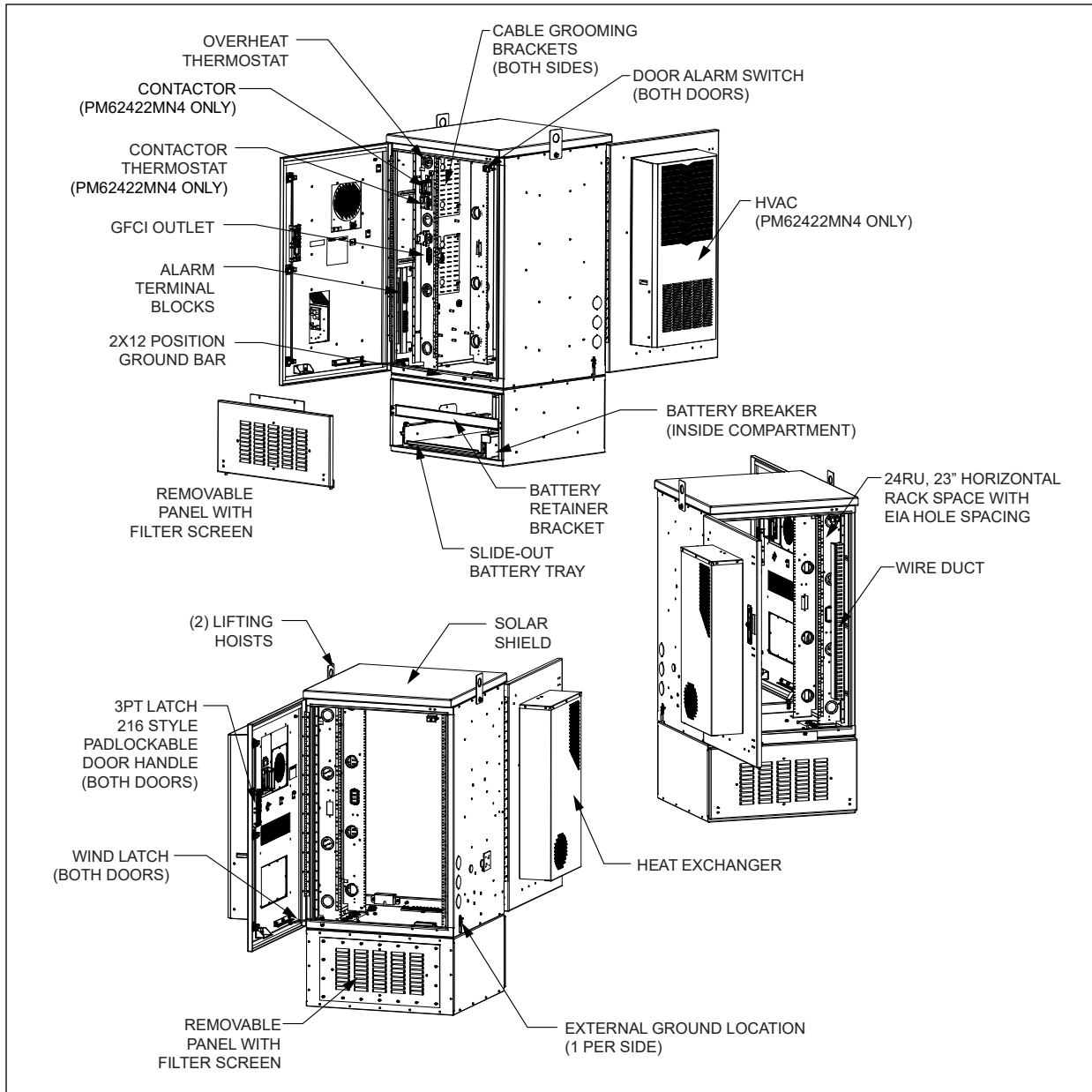

Figure 2 CUBE Dimensions (in inches)



**Figure 3 CUBE Components**  
Except where noted, all components are common to both models.

### 3. INSTALLATION

#### 3.1. Inspecting the Product

The CUBE is shipped mounted upright on a skid. Remove the bolts, unpack the unit, and dispose of the packaging material.

*-INSPECTION NOTE-*

*Visually inspect the unit for damages prior to installation. If the equipment was damaged in transit, immediately report the extent of the damage to the transportation company.*

#### 3.2. Following and Using Safety Precautions

Read the following site and safety tips, cautions, and warnings, then proceed with the paragraphs that follow.

- For installation, follow all National Electrical Codes (NEC) ANSI/NFPA 70, local, environmental, workplace, and company codes, safety procedures, and practices.
- Minimum spacing between the accessories and components and the housing for ITE equipment shall be maintained for safe operation of the equipment when installed in accordance with NEC ANSI/NFPA 70.
- Read all instructions, warnings and cautions on the equipment and in the documentation shipped with the product.
- Always connect ground connections first.
- Do not place this product on weak or unstable surfaces which may allow the product to fall, resulting in potentially serious damage(s) to persons or product.
- Only authorized trained personnel shall install the CUBE.
- In windy conditions, be sure to engage the door latches to secure the door in a stationary position.

#### 3.3. Obtaining Tools and Equipment

Obtain the following recommended or needed items for installing the CUBE.

- Sufficient length and quantities of fiber cable (or pigtails)
- Cable scoring, opening, and cutting tools for cable sheathing, shields, wrappings, strength members and buffer tubes
- Wire strippers
- Crimpers
- Cable, tube, wire, and fiber cleaning materials
- Protective and/or insulated work gloves
- Safety glasses
- Tape measure
- Marking utensil
- #6 ground wire or rod and earth ground materials
- Bond strap (optional, from cable bond clamp to bond post)
- Any exterior cable strain relief, per company practice
- Slotted, hex, and Phillips screwdrivers
- Torque wrench
- Assorted cable ties, clips, or fasteners (optional)
- Can wrench (216 type tool)
- Derrick for lifting
- Level

#### 3.4. Preparing the Installation Site

Observe the following site preparation recommendations.

- Leave adequate horizontal and vertical space between multiple installations to allow for proper cable access, as well as enough room around the enclosure to open the door(s).
- The site must meet minimal personnel and equipment safety requirements.
- The distance from the cable entry point should be consistent with local installation practices.
- The pad or platform must be able to support the weight of the CUBE.
- Run all fiber and copper facilities to the site.

### 3.5. Lifting the CUBE

See Table 1 for CUBE weight. Charles recommends the following procedure for lifting the CUBE.

	<b>WARNING</b>	<b>Prior to lifting, remove the lifting brackets that hold the mounting gasket in place. Set aside the gasket, and then replace the brackets. Failure to do so can result in a failure of the lifting bracket assembly.</b>
--	----------------	---

#### 3.5.1. Required Equipment

- One derrick (crane) capable of lifting the CUBE
- Spreader bar
- Two lifting slings or chains with each having a 2,500 lbs. capacity
- Connecting links to attach slings to the CUBE's lifting brackets
- 75-ft. long tagline rope

Insert the lifting sling connecting links securely through each of the lifting brackets as shown in Figure 4.

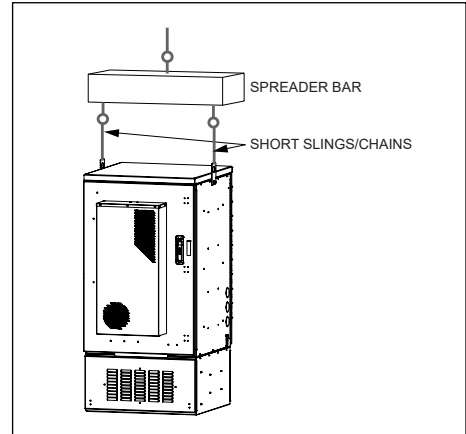

Figure 4 Lifting the CUBE

#### 3.5.2. Warnings and Specific Safety Precautions

	<b>WARNING</b>	<b>Improper hoisting equipment and unsafe lifting procedures can result in serious injury or death. Because of the added risk of injury or damage, do not lift enclosures with batteries installed.</b>
--	----------------	---

Observe the following local safety procedures when performing the tasks in this section.

- Keep the CUBE away from any power lines.
- Keep bystanders away from the work operations at all times.
- Only trained operators shall operate the crane for lifting and setting the CUBE.
- Do not suspend loads over people or equipment.
- All persons working with hoisting equipment shall wear standard safety gear according to local practices including safety helmets and steel-toed shoes.
- Do not operate the hoisting equipment until all stabilizers are extended and in firm contact with the ground or adequate support structure.
- Do not attempt to retract or extend the stabilizers while a load is suspended.

### 3.6. Mounting the CUBE

The CUBE can be mounted on a new or existing concrete pad. A loose gasket is provided for placing the CUBE on a concrete pad. If the gasket becomes damaged during installation, order a replacement under part number 39-000598-0. The gasket is not needed if mounting on a CPAD. Ensure that the unit is level.

#### 3.6.1. Torque Requirements

Torque all hardware as shown below (unless otherwise noted). These values apply to SAE Grade 1 & 2 Low Carbon Steel, ASTM A307 Low Carbon Steel, and Stainless Steel Grade 18-8.

Thread Size	In-lbs	Ft-lbs
4-40	4±10%	
6-32	8±10%	
8-32	16±10%	
10-32	26±10%	
12-24	50±10%	
1/4-20/M6	60±5%	5±5%
5/16-18	125±5%	10.4±5%
3/8-16	180±5%	15.0±5%
1/2-13	500±2%	41.7±2%
5/8-11	1000±1%	83.3±1%

**3.6.2. Constructing a New Pad**

- Use only concrete for new pad construction. Do not use substitute materials since they lack the rigidity for CUBE placement.
- Observe local building practices for pad construction. Charles recommends that the pad should extend a minimum of 8” beyond the CUBE base on all sides.
- Use a minimum of 6” of sand or gravel as a base for the pad for leveling purposes.
- Figure 5 shows the required conduit openings and mounting hole dimensions for entering/mounting the bottom of the CUBE. Use these dimensions when designing the pad.

	<b>WARNING</b>	<p><b>When pad mounting, the compression strength of the pad must be at least 4000 psi as determined by ASTM C39 test of compression strength of concrete cylinders.</b></p> <p><b>The slump of the concrete shall be 2” to 4” as determined by ASTM C143 test method.</b></p>
--	----------------	--

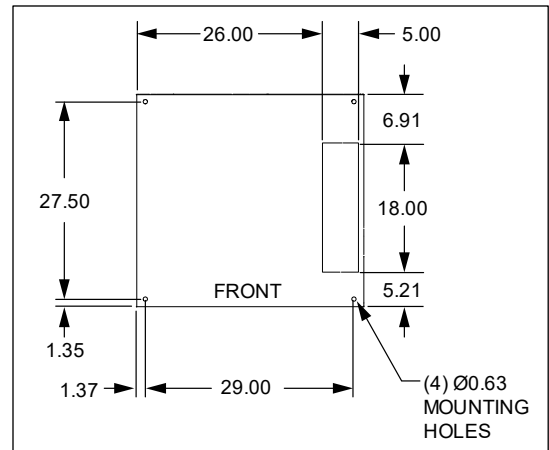
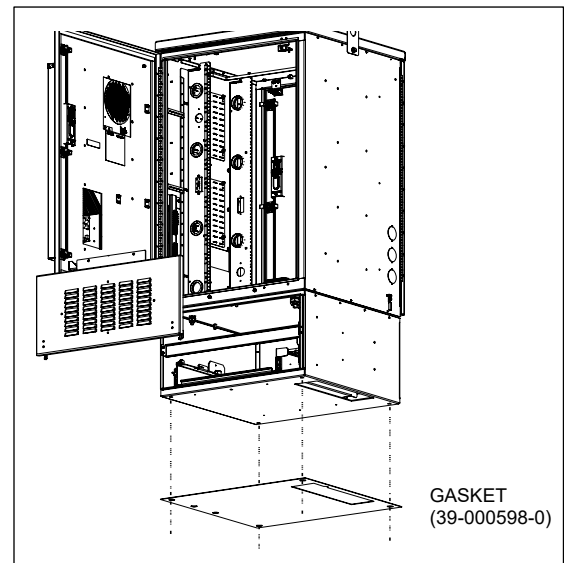

**Figure 5**  
**Mounting Hole Dimensions (in inches), Top View**

**3.6.3. Mounting the CUBE on a Pad**

Four customer supplied, corrosion resistant, 1/2”-13 hex head bolts with anchors are required for mounting the CUBE to the concrete pad. Use the following steps to mount the CUBE to a pad.

1. Layout, drill, and set the 1/2” anchors per manufacturer’s recommendations. The embedment depth is not to exceed 3.5”. Use the gasket as a mounting hole location template.
2. Clean any debris from the concrete pad.
3. Install the gasket by positioning it on the pad so that it is underneath the bottom of the CUBE when the cabinet is installed. Line up the gasket so that the cutouts are in proper position around the conduit opening and the bolt holes as shown in Figure 6.
4. Open the equipment chamber door and remove the screws at the top of the battery compartment cover. Open the battery compartment to allow access to mounting holes.
5. Ensure that the CUBE is parallel to the pad surface as it is placed onto the pad and that it aligns with the holes in the pad and the gasket. Dress the cable/conduit so that it aligns with the CUBE openings as it is lowered onto the pad.
6. Place the CUBE on the pad. Loosen the slings so that all the weight is on the pad. Check that the CUBE is properly aligned.
7. Secure the CUBE to the pad using the 1/2”-13 hex head bolts. Tighten all bolts securely.
8. Once the CUBE is secured, remove the slings and tagline. Replace any panels removed and close the equipment compartment door.



**Figure 6**      **Gasket Installation**

### 3.8. CUBE Wiring and Equipment

After the CUBE is properly mounted in the desired location, apply No-Ox where bus bar and other 2-hole lug connections will be made. Install ground and power connections. Always ground the equipment first, before making any other connections.

	<b>WARNING</b>	<b>Perform all bonding and grounding connections prior to any electrical and communications connections.</b>
---	----------------	--

In order to prevent condensation prior to being placed in service, do not remove the desiccant until the CUBE is sealed and power is applied. Basic electrical diagrams are shown in Figures 7 and 8.

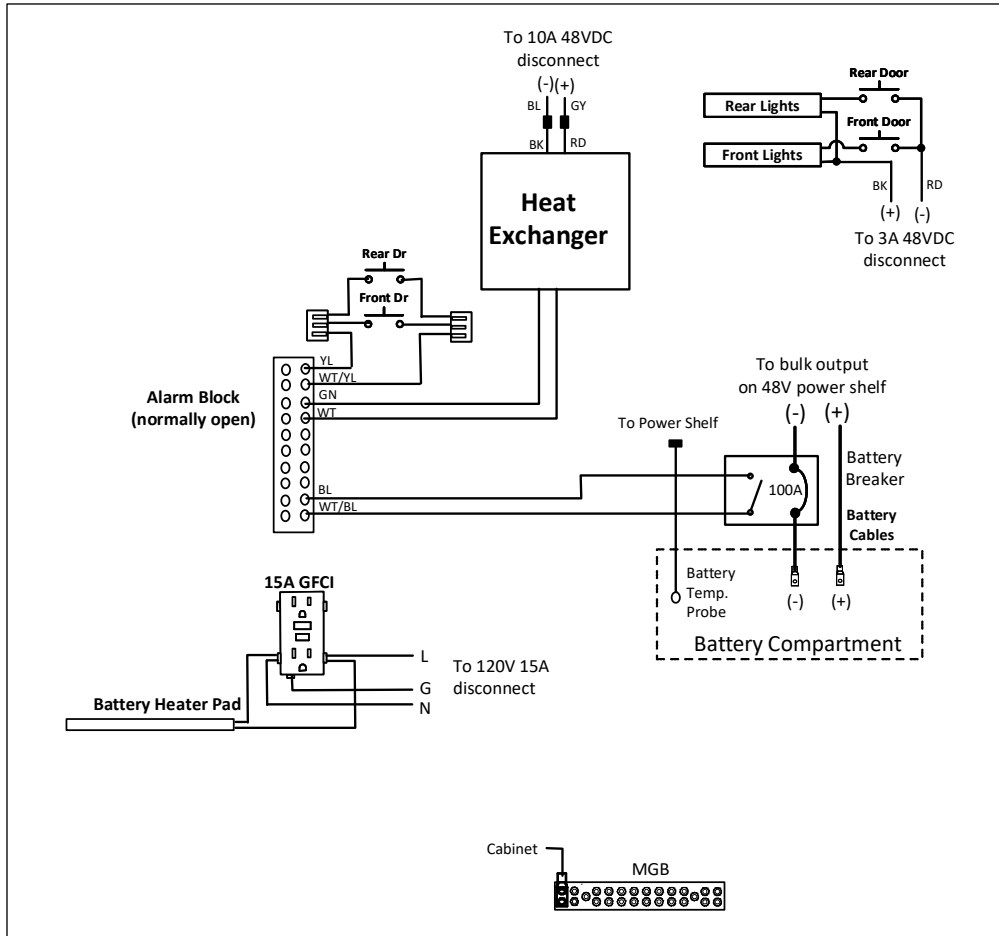

Figure 7 PM62422MN3 Electrical Diagram

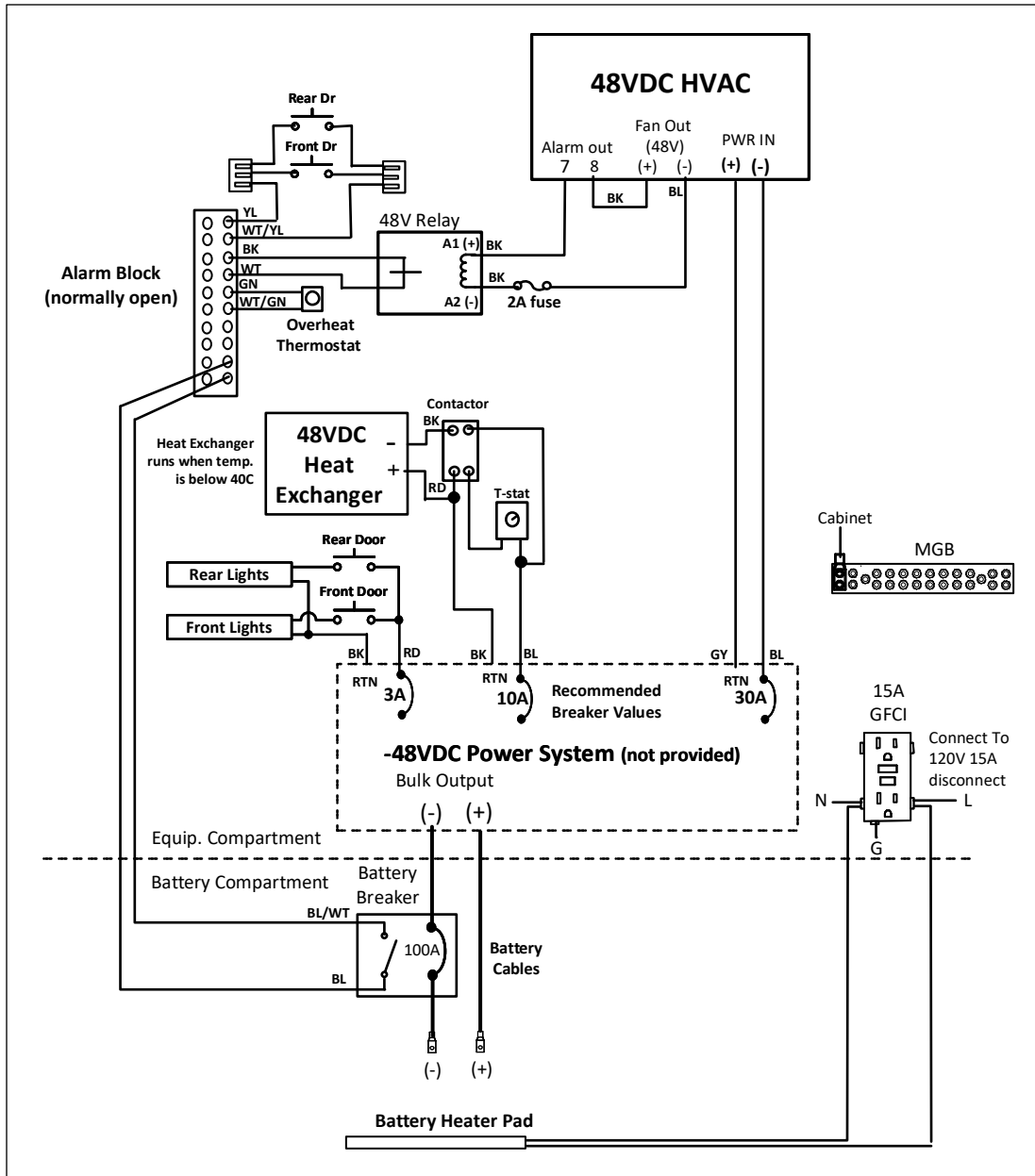



Figure 8 PM62422MN4 Electrical Diagram



### 3.8.1. Ground Connection

Use the 2x12 position ground bar provided in the equipment compartment for all grounding of internal equipment. Stack hardware as shown in Figure 9. External ground lugs are available on the sides of the CUBE for connecting a site ground wire.

### 3.8.2. Battery Connection

	<b>WARNING</b>	<p><b>Always turn off battery breakers prior to servicing batteries.</b></p> <p><b>If using VRLA batteries, ensure that the power system is set up for VRLA batteries with temperature compensation enabled.</b></p>
---	----------------	--

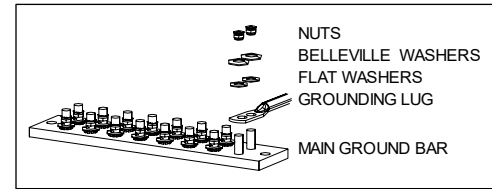

**Figure 9**  
**Ground Bar Hardware Stack**

Verify the polarity of the cables prior to terminating them to the batteries. Ensure the battery terminations are properly insulated to avoid shorting prior to terminating to the batteries.

1. Switch off the battery breaker located in the battery compartment.
2. Open the equipment chamber door and remove the two screws at the top of the battery compartment cover panel, then set aside the panel. Then remove the four screws on the retaining bracket in front of the battery tray and set the bracket aside. To unlock the battery tray, press down on the left side lever and slide the battery tray forward.
3. If replacing batteries, disconnect battery cables from terminals and loosen the battery retaining strap(s).
4. Remove the battery temperature probe.
5. Remove the interconnecting straps from the batteries. Remove batteries.
6. Carefully position the new batteries on the battery tray. Connect the interconnecting straps to each battery string. Slide the battery tray back into the locked position and replace the battery bracket using the four screws removed previously. Fasten the door back on using the two screws.
7. Replace battery temperature probe to the closest battery.
8. Connect the battery cables to the appropriate terminals.
9. Secure the battery retaining straps and reinstall the battery retainer brackets using hardware from step 2.
10. Properly manage the battery cables.
  - o Ensure that the bending radius does not exceed 5x the cable diameter (e.g. 4/0 battery cable = 4 inch bend radius).
  - o Use as few bends as possible between the two termination points.
  - o Do not bend the cable at the termination points.
11. Switch on the battery breaker.

Notes:

- Battery breakers terminate at the power shelf.
- Ensure temperature compensation probes are installed per power system guidelines.
- Ensure back up battery amperage is inputted into the power system controller per power system guidelines.
- Ensure float voltage is set per power system and battery guidelines.
- Ensure all battery terminations and bus bars have No Ox applied.
- Refer to the battery manufacturer’s documentation for proper battery installation and maintenance information.

### 3.8.3. Battery Temperature Probe

The CUBE includes a battery temperature probe, wired in series and connected to the power system. When the batteries are installed, connect the probe to the nearest battery on the battery tray. The probe monitors the temperature of the batteries and sends the information to the power system, which adjusts the voltage draw from the batteries in response to thermal changes.

### 3.8.4. Battery Heater Pad

The 100W heater pad in the bottom of the battery compartment is controlled by an internal thermostat that turns on at 15°C and turns off at 24°C. The heater pad is connected the GFCI outlet.

**3.8.5. Heat Exchanger Operation**

The 1880W DC powered heat exchanger in the equipment compartment has a fan speed controller and includes an internal and an external fan. The fans’ speed increases with increasing ambient temperature. Fan settings are defined below.

Fan Setting	Internal	External
Turn-on Setting	-40°C	30°C
Medium Temp Setting	30°C	40°C
High Temp Setting	45°C	55°C

For more information, refer to the heat exchanger documentation found inside the CUBE.

-NOTE-

*Changing the speed controller default factory set points can lead to system performance issues, such as equipment failures, increased power use, unnecessary alarms, noise, condensation build up, fan failure caused by excessive runtimes and vibration. Avoid placing items in front of the heat exchanger’s return and supply vents. Maintain a minimum of 6” clearance to enable proper air flow.*

**3.8.6. HVAC Operation (PM62422MN4 Only)**

The 5100BTU (5kBTU) DC powered HVAC compressor and fans are PID (proportional integral derivative) controlled. The compressor turns on at 33°C at low speed and will increase/decrease speed as needed to maintain this temperature. The compressor turns off when the internal temperature reaches 28°C. The internal fan is always on at low speed (30%) to continually circulate heat within the cabinet. The external fan turns on/off with the compressor. Both fans’ speed increase as needed with increasing internal cabinet temperature. In addition, the HVAC includes a built-in 1000W heater for cold temperature operation. HVAC settings for the compressor, fans, heater, and temperature alarms are defined below and are based off the cabinet’s interior temperature. The CUBE is equipped with a cutoff switch that shuts off the HVAC compressor when a door is opened to minimize condensation buildup on the coils.

The maximum airflow amount supplied to the equipment by the HVAC is 306CFM. For further information, refer to the HVAC documentation that ships with the CUBE.

HVAC Compressor/Fans/Heater/Alarms Setting	Internal	External
Compressor Turn-on Setting	33°C	N/A
Compressor Turn-off Setting	28°C	N/A
Fan Turn-on Setting	-40°C	33°C
Heater ON Setting (70% Fan Speed)	8°C	N/A
Heater OFF Setting	13°C	N/A
High Temp Alarm Setting	65°C	N/A
Low Temp Alarm Setting	0°C	N/A

-NOTE-

*Changing the cooling or heating cycles’ default factory set points can lead to system performance issues, such as equipment failures, increased power use, unnecessary alarms, noise, condensation build up, compressor or fan failure caused by excessive runtimes and vibration. Avoid placing items in front of the HVAC’s return and supply vents. Maintain a minimum of 6” clearance to enable proper air flow.*

**3.8.7. Contactor Operation (PM62422MN4 Only)**

The PM62422MN4 has a contactor controlled by a thermostat to shut off the heat exchanger when the CUBE’s internal temperature reaches 40°C ± 4°C, allowing the HVAC to operate alone. This protects the equipment from overheating. The contactor will turn the heat exchanger back on when the internal temperature drops below 33°C ± 4°C. Note that there at some moments between these ON/OFF cycles, both the HVAC and the heat exchanger operate simultaneously.

**3.8.8. Alarm Block Connections**

A pair of 10-position, labeled alarm block monitor components in the equipment compartment. See the electrical diagram for information about alarm connections. All connections are normally open and will close upon alarm.

**3.8.9. Fiber and Copper Entry**

The sides of the CUBE have Ø2.50” knockouts that accommodate Ø2.00” conduit fittings. See Figure 2 for knockout locations.

### 3.9. Conduit Seals

All internal and external conduit openings on the CUBE must be completely sealed with a duct seal compound to prevent moisture from entering the equipment compartment. The battery compartment (if present) must be internally sealed from the equipment compartment to prevent outgassing from the batteries into the equipment compartment. Use a moldable, flame-retardant putty style duct seal material. Do not use an expanding foam seal. Mold the putty so that the open space around the wire or conduit is completely sealed, as shown in Figure 10. If the openings must be accessed at any time, remove the putty and set it aside. When work is complete, re-mold the putty to re-seal the opening.

### 3.10. Verifying the Installation

Verify that earth ground and all grounding and bonding is complete and functional. After verifying that all installer connections are secure and complete, apply voltage.

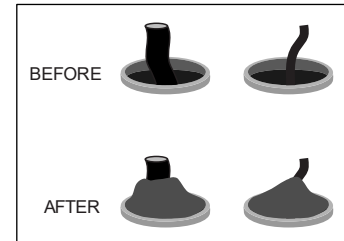

Figure 10 Applying Putty Seal

## 4. PERIODIC MAINTENANCE

In the event that the enclosure must be opened in freezing conditions, use a narrow, pointed metallic object such as a screwdriver or chisel, along with a non-metallic device like a rubber mallet, to remove excessive ice buildup around the door and locking mechanism. A commercial aerosol de-icer spray can be used to free up locks and latches if needed. Use protective gloves and safety glasses when applying de-icer sprays.

Periodic cleaning of the filter screens is important to maintain proper ventilation. To clean the filter screens, remove the four nuts on each screen and take out the screens. Use a soft brush or hose to remove any debris from the screen. Once clean, replace the screens using the four nuts removed previously.

Reset the GFCI duplex receptacle periodically to ensure it is working. The unit meets UL-943, which requires an auto-monitoring (self-testing) feature. A flashing or solid red LED indicates a fault. If the unit continues to show a fault after resetting, replace the unit.

The heat exchanger requires no scheduled maintenance other than cleaning the fans and heat exchanger core if they become contaminated with dust or residue. Remove the cover by removing the screws on the outside. Examine periodically to determine the required cleaning periods based on the installed environmental conditions.

Refer to the HVAC manual supplied with the HVAC for periodic maintenance requirements.

## 5. TECHNICAL ASSISTANCE AND REPAIR SERVICE

For questions on product repair or if technical assistance is required, contact Charles Technical Support.

847-806-8500

[techserv@charlesindustries.com](mailto:techserv@charlesindustries.com) (email)

<http://www.charlesindustries.com/techserv.htm>

## 6. WARRANTY & CUSTOMER SERVICE

Charles Industries LLC offers a one-year warranty on the CUBE product. The Charles warranty is limited to the operation of the CUBE hardware as described in this documentation and does not cover equipment which may be integrated by a third party. The terms and conditions applicable to any specific sale of product shall be defined in the resulting sales contract. For questions on warranty or other customer service assistance, contact your Charles Customer Service Representative.

847-806-6300

[mktserv@charlesindustries.com](mailto:mktserv@charlesindustries.com) (email)

[http://www.charlesindustries.com/main/telecom\\_sales\\_support.htm](http://www.charlesindustries.com/main/telecom_sales_support.htm)

## 7. SPECIFICATIONS

### 7.1. Regulatory Specifications

- Designed to meet GR-487
- GFCI: UL-943 Listed

If CUBE's are field-modified, a customer provided ETL field evaluation of the modified components may be required to re-establish ETL certification to UL standards. Consult local jurisdictions for guidance on a site-by-site basis.

### 7.2. Product Specifications

<b>Physical</b>	
Dimensions	66"Hx32"Wx32"D
Weight	PM62422MN3: Approx. 406 lbs. as shipped PM62422MN4: Approx. 480 lbs. as shipped
23" Equipment Rack Space and Hole Spacing	42" (24RU) rack spacing with tapped EIA #12-24 mounting holes
Battery Tray Size	12.75"Hx21"Wx24"D
Maximum Supported Weight	Rack Rails: 264 lbs. Battery Tray: 500 lbs.
Materials	0.125" aluminum
Color	Off-white
<b>Electrical</b>	
Supported Batteries	200Ah, VRLA
Contactors	PM62422MN4 Only: 48VDC, 50A, Gigavac P115FDA
Bonding and Grounding	One 2x12 position ground bar in equipment compartment, 2 external lugs
Cable Entry	See Figure 2 and section 3.8.8
<b>Thermal</b>	
Heat Exchanger	1880W, 48VDC, Dantherm 705882
Maximum Heat Capacity	1800W@19°C above ambient with solar
HVAC	PM62422MN4 Only: 48VDC Vikinor VAK-1500
Cooling Capacity	PM62422MN4 Only: 5000BTU
<b>Environmental</b>	
Operating Temp. Range, Outside Enclosure	-40° to +115°F, -40° to 46°C
Operating Temp Range, Inside Enclosure	-40° to +149°F, -40° to 65°C
Humidity	0 to 95% (non-condensing)
Altitude	Up to 2,000 meters (6560 feet)
<b>Kits and Replacement Parts</b>	
Touch-up Paint	02-000290-0
216 Type Security Tool	07-002070-0
Replacement Gasket	39-000598-0
Shim Kit for Leveling	97-000010-0
Lift-Up Handle	39-000335-0
Door Rod Latch	39-000336-0
4-Wire Door Alarm Switch (Black)	17-400329-0
GFCI Outlet	15A 04-100207-0
Overheat Thermostat	99-004548-0
Contactors Control Thermostat	PM62422MN4 Only: 99-0042354-0

Table 1 CUBE Specifications