

# Charles Replacement Door Kit

## 97-SS4C15FR4KDT

### General Description and Installation

- 1. GENERAL INTRODUCTION .....1
  - 1.1. Document Purpose .....1
  - 1.2. Product Purpose.....1
- 2. INSTALLATION .....2
  - 2.1. Inspecting the Product.....2
  - 2.2. Following and Using Safety Precautions.....2
  - 2.3. Obtaining Tools and Equipment.....2
  - 2.4. Mounting the Kit.....2
- 3. TECHNICAL ASSISTANCE AND REPAIR SERVICE .....5
- 4. WARRANTY & CUSTOMER SERVICE .....5
- 5. SPECIFICATIONS.....5

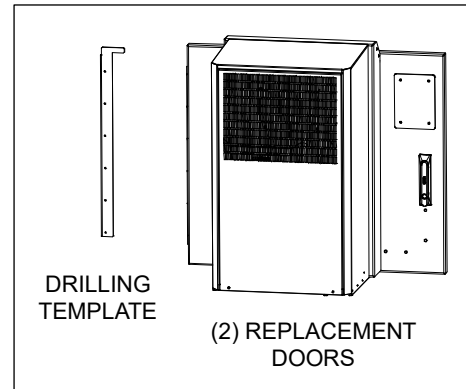

**Figure 1     Kit Components**

## 1. GENERAL INTRODUCTION

### 1.1. Document Purpose

This document provides general information for the 97-SS4C15FR4KDT replacement door kit for the CUBE-SS4C215XC2 cabinet. Figure 1 shows the kit components. Hardware is not shown.

*-NOTE-*

*Hereafter, the Charles 97-SS4C15FR4KDT replacement door kit will be referred to as the “kit.” The CUBE-SS4C215XC2 cabinet will be referred to as the “CUBE.”*

### 1.2. Product Purpose

The kit includes two replacement doors. One door replaces the CUBE’s existing front door. The other door replaces the CUBE’s rear panel. A drilling template is included to properly drill mounting holes on the rear of the CUBE.

## 2. INSTALLATION

### 2.1. Inspecting the Product

The kit is shipped mounted upright on a skid. Unpack the unit and dispose of the packaging material.

*-INSPECTION NOTE-*

*Visually inspect the unit for damages prior to installation. If the equipment was damaged in transit, immediately report the extent of the damage to the transportation company.*

### 2.2. Following and Using Safety Precautions

Read the following site and safety tips, cautions, and warnings, then proceed with the paragraphs that follow.

- For installation, follow all National Electrical Codes (NEC) ANSI/NFPA 70, local, environmental, workplace, and company codes, safety procedures, and practices.
- Minimum spacing between the accessories and components and the housing for ITE equipment shall be maintained for safe operation of the equipment when installed in accordance with NEC ANSI/NFPA 70.
- Read all instructions, warnings and cautions on the equipment and in the documentation shipped with the product.
- Do not place this product on weak or unstable surfaces which may allow the product to fall, resulting in potentially serious damage(s) to persons or product.
- Only authorized trained personnel shall install the kit.

### 2.3. Obtaining Tools and Equipment

Obtain the following recommended or needed items for installing the kit.

- Protective and/or insulated work gloves
- Safety glasses
- Marking utensil
- Slotted, hex, and Phillips screwdrivers
- Torque wrench
- Can wrench (216 type tool)

### 2.4. Mounting the Kit

#### 2.4.1. Torque Requirements

Torque all hardware as shown below (unless otherwise noted). These values apply to SAE Grade 1 & 2 Low Carbon Steel, ASTM A307 Low Carbon Steel, and Stainless Steel Grade 18-8.

Thread Size	In-lbs	Ft-lbs
4-40	4±10%	
6-32	8±10%	
8-32	16±10%	
10-32	26±10%	
12-24	50±10%	
1/4-20/M6	60±5%	5±5%
5/16-18	125±5%	10.4±5%
3/8-16	180±5%	15.0±5%
1/2-13	500±2%	41.7±2%
5/8-11	1000±1%	83.3±1%

**2.4.2. Replace the Front Door**

1. Remove the Keps nut that holds the ground strap to the door. Save the nut.
2. Remove the two Keps nuts that hold the wind latch fastened to the CUBE door frame. Save these nuts.
3. Drill out the rivets that hold the door in place (Figure 2). Remove the door. Store or discard the door per company practice.
4. Using the same mounting holes from the old door, mount one of the kit doors onto the front of the CUBE (Figure 3). Secure the door in place using the 5/32 rivets and 8-32 Keps nuts included with the kit.
5. Secure the wind latch and the ground strap using the Keps nuts removed previously.

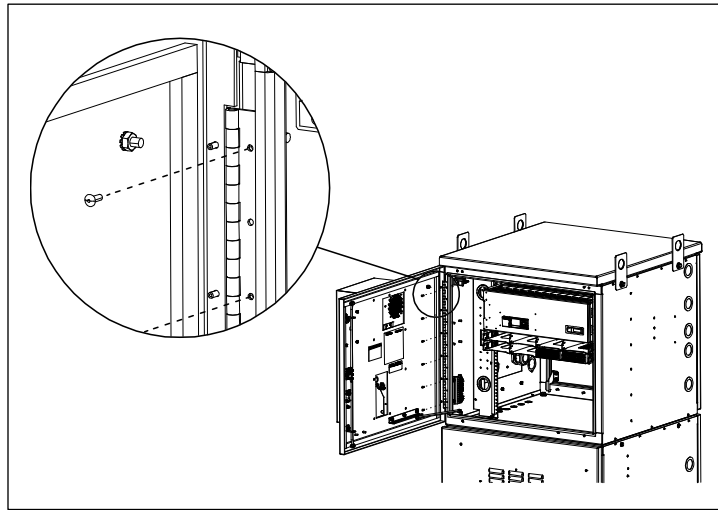

**Figure 2 Remove Rivets**

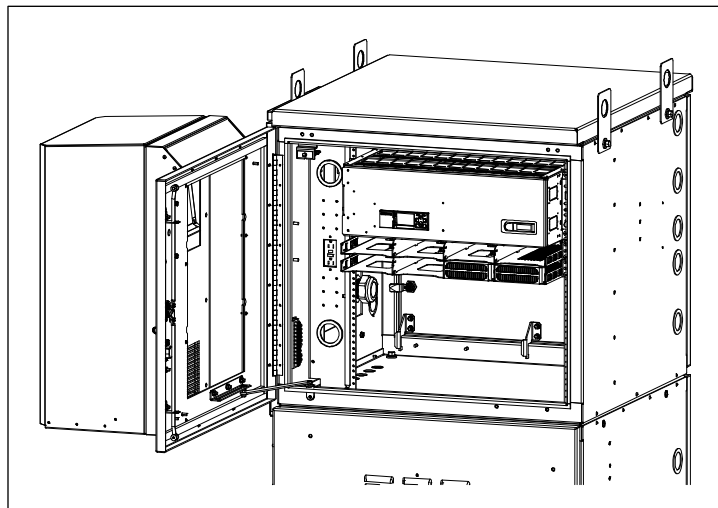

**Figure 3 New Front Door**

**2.4.3. Replace Rear Panel**

1. Remove the CUBE's rear panel. Store or discard the panel per company practice.
2. Place the drilling template so that the template flange fits snugly around the front left corner of the CUBE. Place the short arm around the door frame, flat against the CUBE (Figure 4, template is shaded in gray).
3. Mark the hole locations in the template. Remove the template and set aside.
4. Drill Ø0.172" holes at the marked locations. Apply touch-up paint inside the holes to prevent corrosion.
5. Install the kit door using the 5-32 rivets included with the kit.
6. Use two Keps nuts (included with kit) to secure the wind latch to the studs inside the bottom of the door frame.

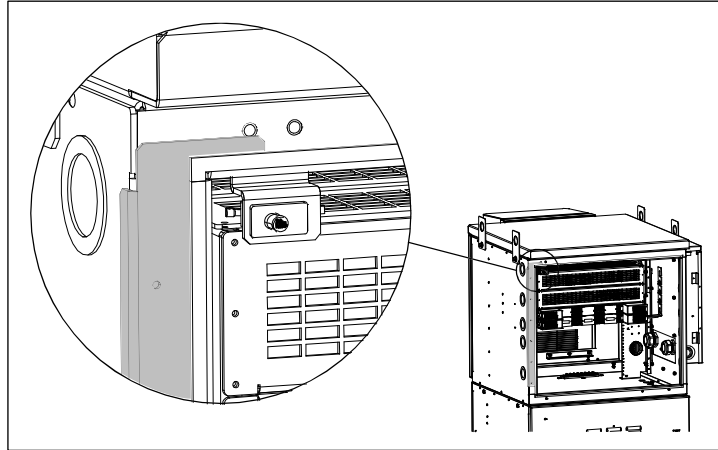

**Figure 4 Place Drilling Template**

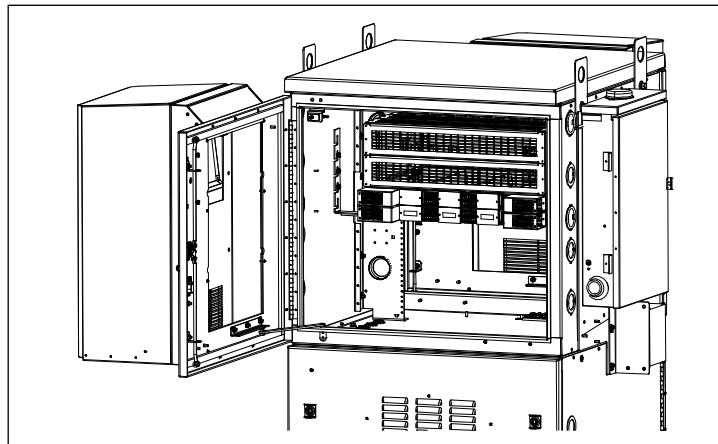

**Figure 5 New Rear Door**

### 3. TECHNICAL ASSISTANCE AND REPAIR SERVICE

For questions on product repair or if technical assistance is required, contact Charles Technical Support.

847-806-8500  
[techserv@charlesindustries.com](mailto:techserv@charlesindustries.com) (email)  
<http://www.charlesindustries.com/techserv.htm>

### 4. WARRANTY & CUSTOMER SERVICE

Charles Industries LLC offers a one-year warranty on the kit product. The Charles warranty is limited to the operation of the kit hardware as described in this documentation and does not cover equipment that may be integrated by a third party. The terms and conditions applicable to any specific sale of product shall be defined in the resulting sales contract. For questions on warranty or other customer service assistance, contact your Charles Customer Service Representative.

847-806-6300  
[mktserv@charlesindustries.com](mailto:mktserv@charlesindustries.com) (email)  
[http://www.charlesindustries.com/main/telecom\\_sales\\_support.htm](http://www.charlesindustries.com/main/telecom_sales_support.htm)

### 5. SPECIFICATIONS

<b>Physical</b>	
Weight	Approx. 110 lbs. as shipped (per door, total 220 lbs.)
Materials	0.125" aluminum
Color	Off-white
<b>Thermal</b>	
HVAC System	48VDC, Dantherm 708345
Cooling Capacity	4000BTU
<b>Environmental</b>	
Operating Temp. Range, Outside Enclosure	-40° to +115°F, -40° to 46°C
Operating Temp Range, Inside Enclosure	-40° to +149°F, -40° to 65°C
Humidity	0 to 95% (non-condensing)
Altitude	Up to 2,000 meters (6560 feet)
<b>Kits and Replacement Parts</b>	
Touch-up Paint	02-000290-0
216 Type Security Tool	07-002070-0

Table 1 CUBE Specifications