

# Charles Universal Broadband Enclosure

## CUBE-SS4B228LN1

### General Description and Installation

<b>1. GENERAL INTRODUCTION</b> .....	<b>1</b>
1.1. Document Purpose .....	1
<b>2. PRODUCT DESCRIPTION</b> .....	<b>1</b>
<b>3. CUBE WIRING AND EQUIPMENT</b> .....	<b>3</b>
3.1. HVAC Operation .....	4
3.2. DAC Operation .....	4
3.3. Alarm Terminal Panel .....	4
<b>4. SPECIFICATIONS</b> .....	<b>4</b>

## 1. GENERAL INTRODUCTION

### 1.1. Document Purpose

This document provides additional information for the CUBE-SS4B228LN1 of the Charles Industries' Universal Broadband Enclosure (CUBE) product line that is not included in the family document, LT-SSXX228XXX. Figure 1 shows a closed front view of the enclosure.

-NOTE-

*Hereafter, the CUBE-SS4B228LN1 Charles Universal Broadband Enclosure will be referred to as the "CUBE."*

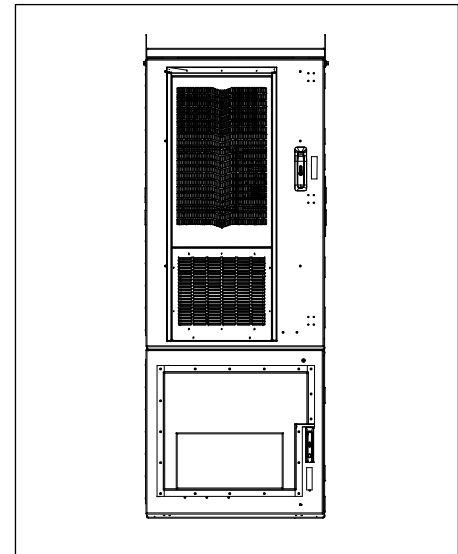

**Figure 1 Front View of the CUBE**

## 2. PRODUCT DESCRIPTION

The equipment compartment includes a 12k BTU DC powered HVAC system. The battery compartment supports two strings of -48VDC Saft NiCd batteries (customer supplied), and it is equipped with a -48VDC direct air cooling system (DAC). Figure 2 shows the components of the CUBE.

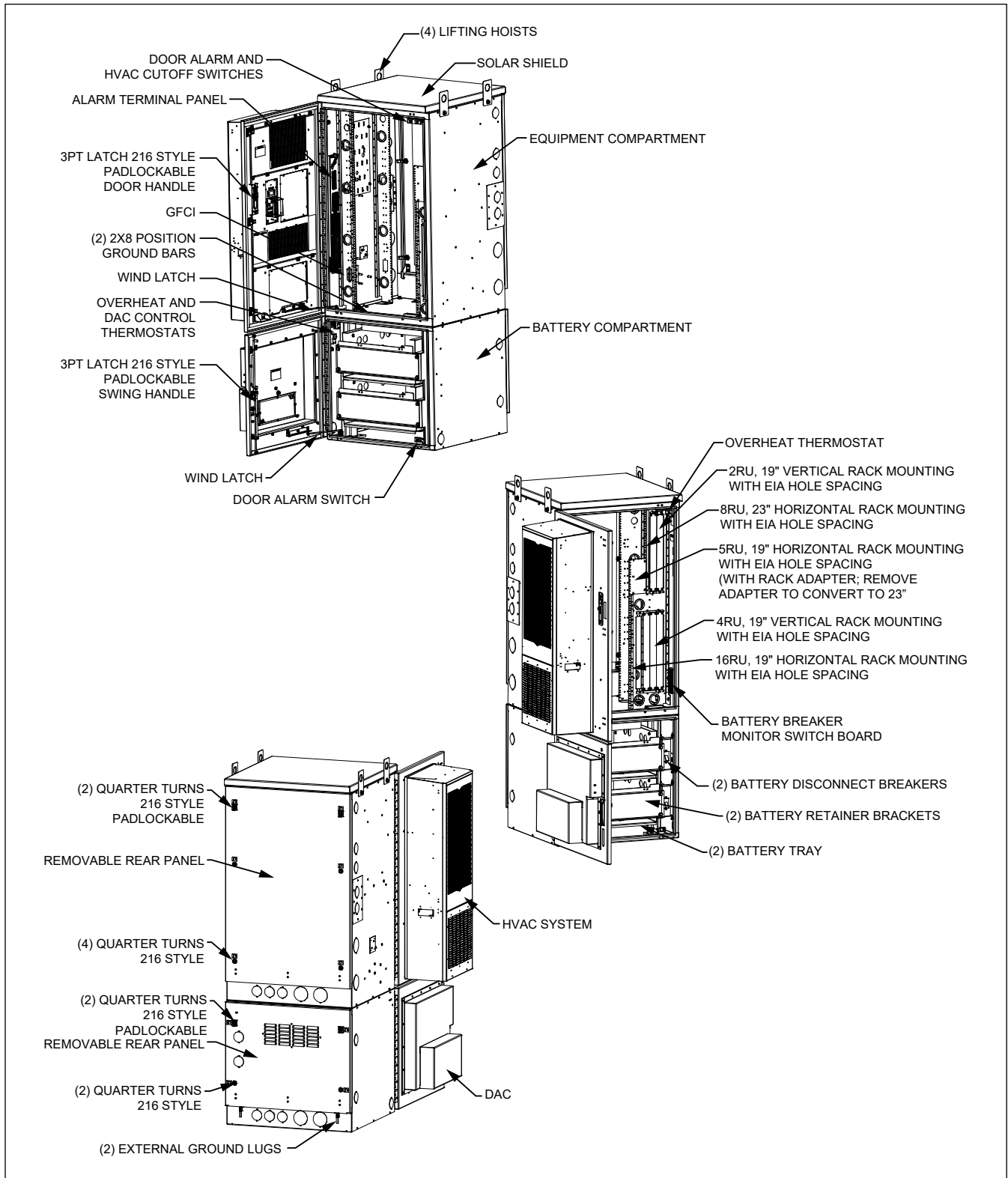

Figure 2 CUBE Components

### 3. CUBE WIRING AND EQUIPMENT

After the CUBE is properly mounted in the desired location, apply No-Ox where bus bar and other 2-hole lug connections will be made. Install ground and power connections. Always ground the equipment first, before making any other connections.

**WARNING** Perform all bonding and grounding connections prior to any electrical and communications connections.

In order to prevent condensation prior to being placed in service, do not remove the desiccant until power is applied to the CUBE. A basic electrical diagram is shown in Figure 3.

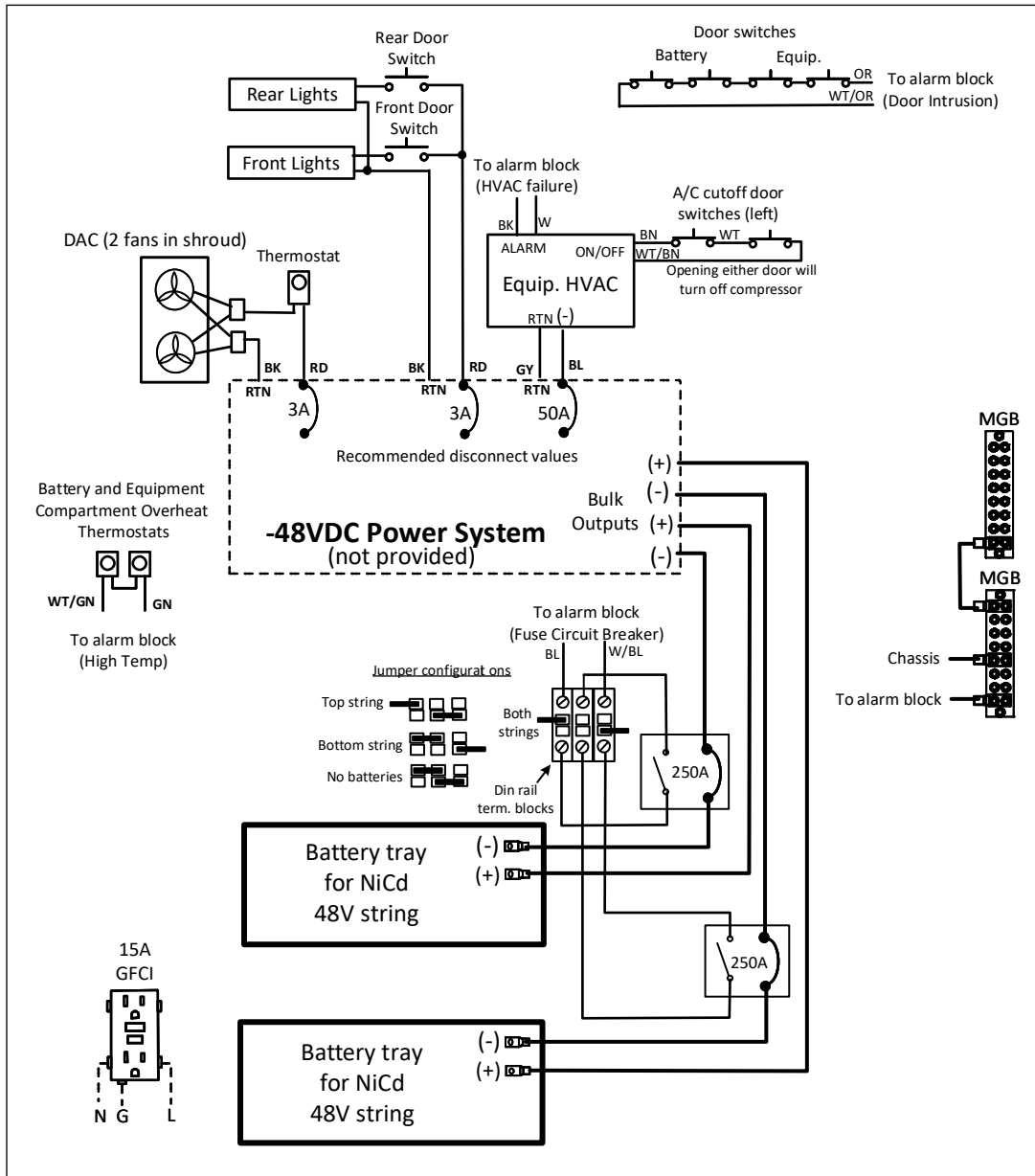

Figure 3 CUBE Electrical Diagram

### 3.1. HVAC Operation

The 12000BTU DC powered HVAC compressor and fans are PID (proportional integral derivative) controlled. The compressor turns on at 33°C at low speed and will increase/decrease speed as needed to maintain this temperature. The compressor turns off when the internal temperature reaches 28°C. The internal fan is always on at low speed (30%) to continually circulate heat within the cabinet. The external fan turns on/off with the compressor. Both fans’ speed increase as needed with increasing internal cabinet temperature. In addition, the HVAC includes a built-in 1000W heater for cold temperature operation. HVAC settings for the compressor, fans, heater, and temperature alarms are defined below and are based off the cabinet’s interior temperature. The CUBE is equipped with a cutoff switch that shuts off the HVAC compressor when a door is opened to minimize condensation buildup on the coils.

The maximum airflow amount supplied to the equipment by the HVAC is 500CFM. For further information, refer to the HVAC documentation that ships with the CUBE

HVAC Compressor/Fans/Heater/Alarms Setting	Internal	External
Compressor Turn-on Setting	33°C	N/A
Compressor Turn-off Setting	28°C	N/A
Fan Turn-on Setting	-40°C	33°C
Heater ON Setting (70% Fan Speed)	8°C	N/A
Heater OFF Setting	13°C	N/A
High Temp Alarm Setting	65°C	N/A
Low Temp Alarm Setting	0°C	N/A

**-NOTE-**

*Changing the cooling or heating cycles’ default factory set points can lead to system performance issues, such as equipment failures, increased power use, unnecessary alarms, noise, condensation build up, compressor or fan failure caused by excessive runtimes and vibration. Avoid placing items in front of the HVAC’s return and supply vents. Maintain a minimum of 6” clearance to enable proper air flow.*

### 3.2. DAC Operation

The DAC system consists of filtered louvers and a shroud with dual fans. The fans are connected to a control thermostat and power. The fan wiring is routed to the equipment compartment and connected to a circuit breaker on the -48VDC power system. The control thermostat is factory set at 30°C (±4°C). The thermostat turns the cooling fans on at the set point and turns them off when the temperature drops by 7°C.

**-NOTE-**

*Changing the thermostat set point from its factory default setting can lead to system performance issues, such as reduced battery life, condensation buildup, excessive runtimes, premature fan failure, and filter clogging, in addition to unnecessary power use, noise, and vibration.*

### 3.3. Alarm Terminal Panel

All alarm wiring is connected to the 40-position alarm panel. Refer to the family practice LT-SSxx228xxx for more information about the panel. The following table shows the macro alarm block wiring for this unit.

Alarm ID	Color	POS	Color	POS2
Door Intrusion	ORG	CC1	WHT/ORG	RET1
HVAC Failure	BLK	CC12	WHT	RET12
High Temp	GRN	CC13	WHT/GRN	RET13
Battery Breaker Alarm	BLU	CC23	BLU/WHT	RET23

## 4. SPECIFICATIONS

Physical	
Weight	Approx. 576 lbs. as shipped
Electrical	
Battery Disconnect Breakers	18-908176-0
Thermal	
HVAC System	48VDC, Vikinor VAK-3000-DC
Cooling Capacity	12000BTU
DAC	243CFM, Delta PFB1248UHE-EP

**Table 1 CUBE Specifications (see family documentation for full list)**