

# Charles Universal Broadband Enclosure

## Site Support Family CUBE-SSxx215xx

### General Description and Installation

<b>1. GENERAL INTRODUCTION .....</b>	<b>1</b>
1.1 Document Purpose .....	1
1.2 Product Purpose.....	1
1.3 Product Mounting and Location.....	1
<b>2. PRODUCT DESCRIPTION.....</b>	<b>2</b>
<b>3. INSTALLATION .....</b>	<b>4</b>
3.1 Inspecting the Product.....	4
3.2 Following and Using Safety Precautions.....	4
3.3 Obtaining Tools and Equipment.....	4
3.4 Preparing the Installation Site.....	4
3.5 Lifting the CUBE.....	5
3.6 Mounting the CUBE.....	5
3.7 CUBE Wiring and Equipment .....	7
3.8 Conduit Seals.....	8
3.9 Verifying the Installation.....	8
<b>4. PERIODIC MAINTENANCE.....</b>	<b>8</b>
<b>5. TECHNICAL ASSISTANCE AND REPAIR SERVICE.....</b>	<b>8</b>
<b>6. WARRANTY &amp; CUSTOMER SERVICE .....</b>	<b>9</b>
<b>7. SPECIFICATIONS.....</b>	<b>9</b>
7.1 Regulatory Specifications.....	9
7.2 Product Specifications.....	9
7.3 CUBE Models and Individual Specifications.....	10
7.4 Supported Batteries .....	10

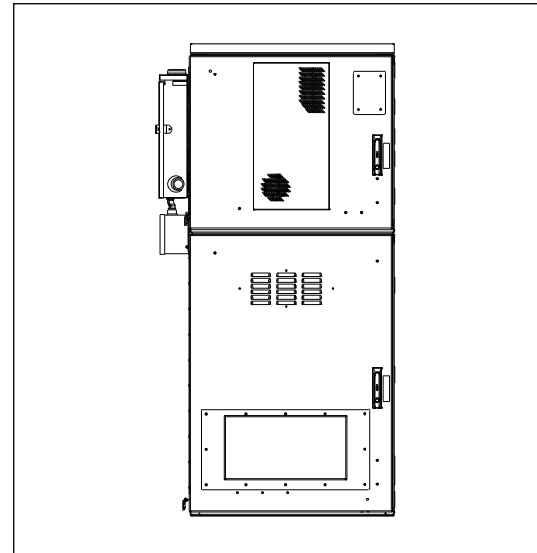

**Figure 1 Front View of the CUBE**

## 1. GENERAL INTRODUCTION

### 1.1 Document Purpose

This document provides general information for the CUBE-SSXX215XXX family of the Charles Industries' Universal Broadband Enclosure (CUBE) product line. Supplemental documentation that ships with the CUBE contains more detailed information about the models. Figure 1 shows a closed front view of the enclosure.

-NOTE-

*Hereafter, the CUBE-SSXX215XXX Charles Universal Broadband Enclosure will be referred to as the "CUBE."*

### 1.2 Product Purpose

The CUBE consists of a protective enclosure for an integrated system of electronic components and equipment that can serve fiber and copper interfaces.

### 1.3 Product Mounting and Location

This enclosure is suitable for outside plant-type (OSP) locations and those that may require NEC compliance. The outdoor, weather-resistant CUBE is to be mounted on a pad or platform. The installer connects the power, fiber and copper connections. Detailed mounting and installation information is covered in Section 3. Charles recommends the CPAD composite pad for pad mounting applications.

## 2. PRODUCT DESCRIPTION

The CUBE includes a battery compartment and an equipment compartment. The equipment compartment has 15RU of 23" rack mount spacing and a 750W DC powered heat exchanger. The battery compartment supports three strings of batteries. The differences among the various models are in the battery thermal devices, the AC load center, and the power shelf (see Table 2).

Figure 2 shows a dimensional drawing of the CUBEs. Figure 3 shows the added dimensions of the thermal units. Figure 4 shows the rear view. The supplemental documentation that ships with the CUBE includes a diagram of the CUBE components.

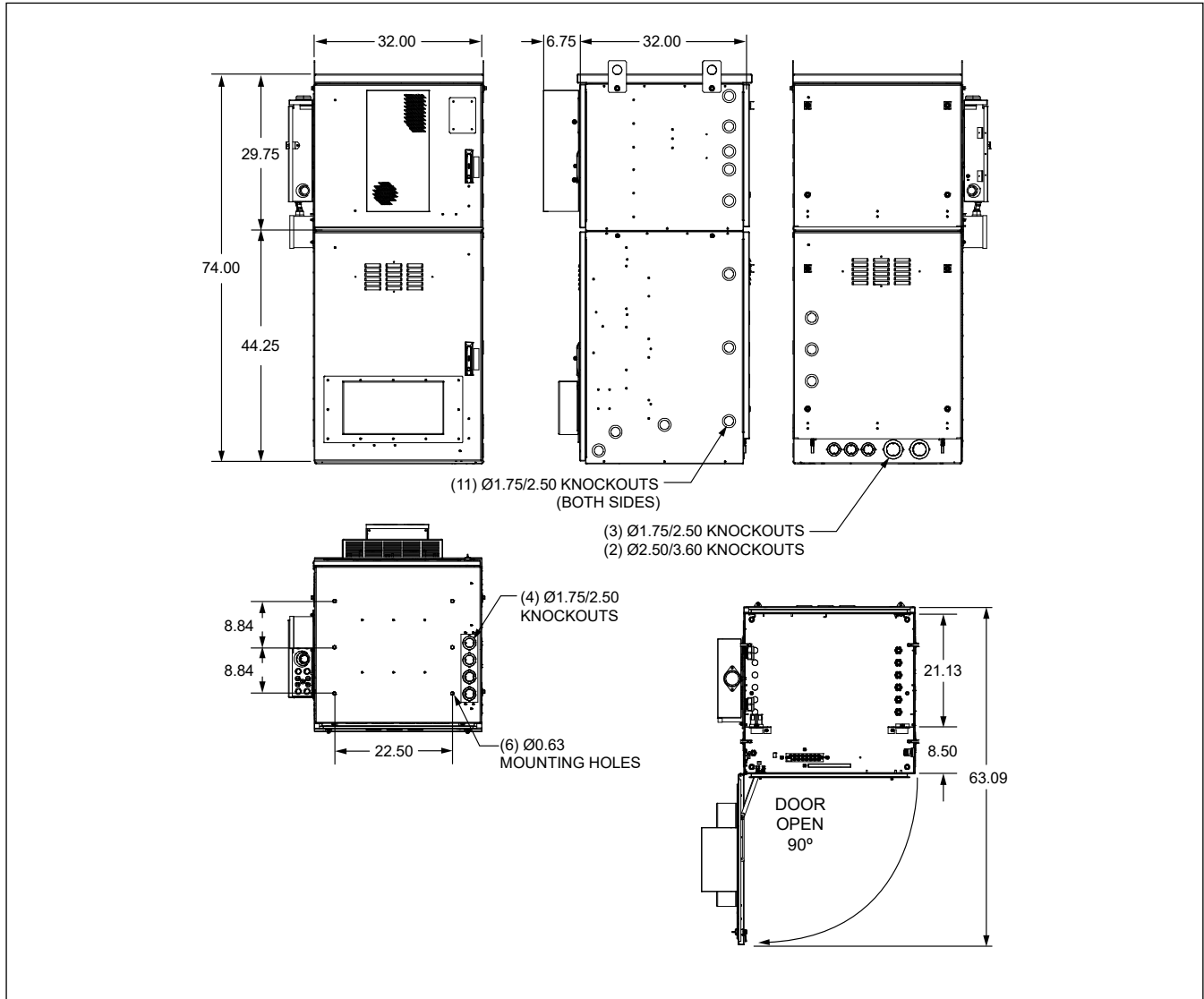
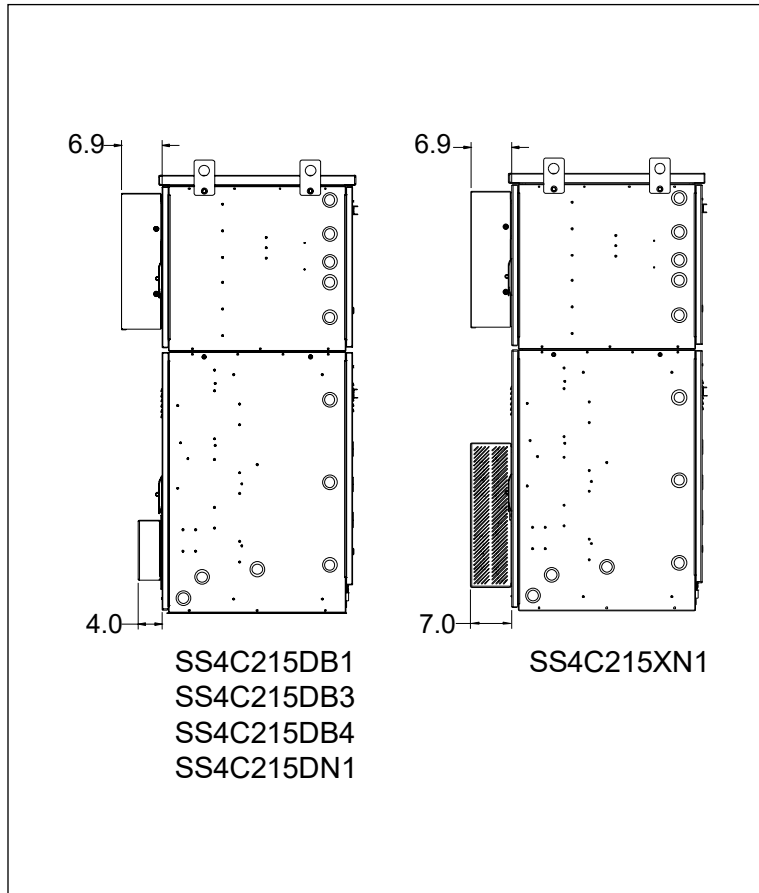
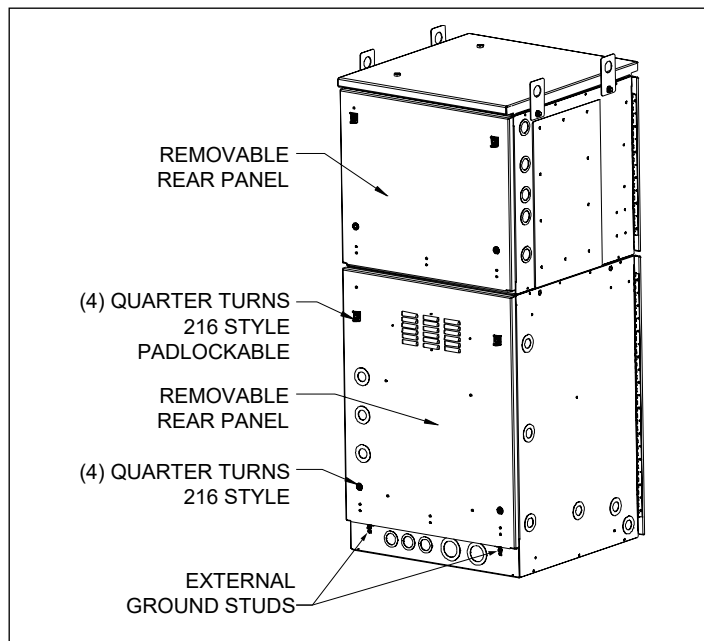

Figure 2 CUBE Dimensions (in inches)



**Figure 3 CUBE Dimensions (in inches) of Thermal Units**



**Figure 4 CUBE Rear View (all models)**

### 3. INSTALLATION

#### 3.1 Inspecting the Product

The CUBE is shipped mounted to a skid. Remove the bolts, unpack the unit, remove and dispose of the packaging material.

*-INSPECTION NOTE-*

*Visually inspect the unit for damages prior to installation. If the equipment was damaged in transit, immediately report the extent of the damage to the transportation company.*

#### 3.2 Following and Using Safety Precautions

Read the following site and safety tips, cautions, and warnings, then proceed with the paragraphs that follow.

- For installation, follow all National Electrical Codes (NEC) ANSI/NFPA 70, National Electrical Safety Codes (NEC), OSHA requirements, local, environmental, workplace, and company codes, safety procedures, and practices.
- Minimum spacing between the accessories and components and the housing for ITE equipment shall be maintained for safe operation of the equipment when installed in accordance with NEC ANSI/NFPA 70.
- Read all instructions, warnings and cautions on the equipment and in the documentation shipped with the product.
- Always connect ground connections first.
- Do not place this product on weak or unstable surfaces which may allow the product to fall, resulting in potentially serious damage(s) to persons or product.
- Only authorized trained personnel shall install the CUBE.
- In windy conditions, be sure to engage the door latch(es) to secure the door in a stationary position.

#### 3.3 Obtaining Tools and Equipment

Obtain the following recommended or needed items for installing the CUBE.

- Wire strippers
- Crimpers
- Cable, tube, wire, and fiber cleaning materials
- Protective and/or insulated work gloves
- Safety glasses
- Tape measure and marking utensil
- #6 ground wire or rod and earth ground materials
- Bond strap (optional, from cable bond clamp to bond post)
- Any exterior cable strain relief, per company practice
- Slotted, hex, and Phillips screwdrivers
- Torque wrench
- Assorted cable ties, clips, or fasteners (optional)
- Can wrench (216 type tool)
- 7/16" wrench
- Derrick (crane) for lifting
- Level

#### 3.4 Preparing the Installation Site

Observe the following site preparation recommendations:

- Leave adequate horizontal and vertical space between multiple installations to allow for proper cable access, as well as enough room to open the doors.
- The site must meet minimal personnel and equipment safety requirements.
- The distance from the cable entry point should be consistent with local installation practices.
- The pad or platform must be able to support the weight of the CUBE.

### 3.5 Lifting the CUBE

See the supplemental documentation for CUBE weight.

	<b>WARNING</b>	<b>Prior to lifting, remove the lifting brackets that hold the mounting gasket in place. Set aside the gasket, and then replace the brackets. Failure to do so can result in a failure of the lifting bracket assembly.</b>
--	----------------	---

#### 3.5.1 Required Equipment

- One derrick (crane) capable of lifting the CUBE
- Spreader bars
- Four lifting slings or chains with each having a 2,500 lbs. capacity
- Connecting links to attach slings to the CUBE's lifting brackets
- 75-ft. long tagline rope

Insert the lifting cable sling connecting links securely through each of the lifting brackets as shown in Figure 5.

#### 3.5.2 Warnings and Safety Precautions

	<b>WARNING</b>	<b>Improper hoisting equipment and unsafe lifting procedures can result in serious injury or death. Because of the added risk of injury or damage, do not lift enclosures with batteries installed.</b>
--	----------------	---

Observe the following local safety procedures when performing the tasks in this section:

- Keep the CUBE away from any power lines.
- Keep bystanders away from the work operations at all times.
- Only trained operators shall operate the crane for lifting and setting the CUBE.
- Do not suspend loads over people or equipment.
- All persons working with crane equipment shall wear standard safety gear according to local practices including safety helmets and steel-toed shoes.
- Do not operate the crane until all stabilizers are extended and in firm contact with the ground or adequate support structure.
- Do not attempt to retract or extend the stabilizers while a load is suspended.

### 3.6 Mounting the CUBE

The CUBE can be mounted on a new or existing precast concrete pad or steel grate platform directly or with optional plinth kit 97-002162-A. Charles recommends the CPAD-MM1EXX single bay pad with the optional CPAD-MM1EXXEXT extension. A gasket is provided for placing the CUBE on a concrete pad. If the gasket becomes damaged during installation, order a replacement under part number 39-000352-0. The gasket is not needed if mounting on a CPAD.

#### 3.6.1 Torque Requirements

Torque all hardware as shown below (unless otherwise noted). These values are appropriate for SAE Grade 1 & 2 Low Carbon Steel, ASTM A307 Low Carbon Steel, and Stainless Steel Grade 18-8.

Thread Size	In-lbs	Ft-lbs
4-40	4±10%	
6-32	8±10%	
8-32	16±10%	
10-32	26±10%	
12-24	50±10%	
1/4-20/M6	60±5%	5±5%
5/16-18	125±5%	10.4±5%
3/8-16	180±5%	15.0±5%
1/2-13	500±2%	41.7±2%
5/8-11	1000±1%	83.3±1%

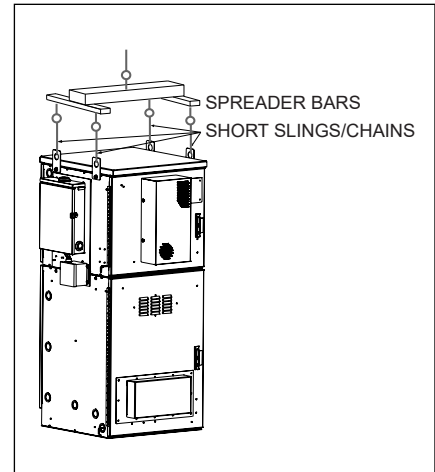
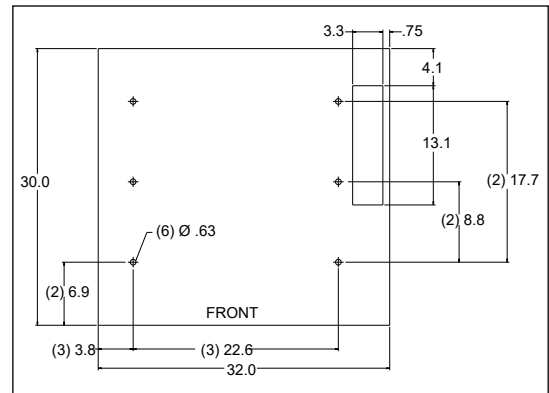

Figure 5 Lifting the CUBE

**3.6.2 Constructing a New Pad**

- Use only concrete for new pad construction. Do not use substitute materials since they lack the rigidity for CUBE placement.
- Observe local building practices for pad construction. Charles recommends that the pad should extend a minimum of 8” beyond the CUBE base on all sides.
- Use a minimum of 6” of sand or gravel as a base for the pad for leveling purposes.
- Figure 6 shows the required conduit openings and mounting hole dimensions for entering/mounting the bottom of the CUBE. Use these dimensions when designing the pad.

	<b>WARNING</b>	<p><b>When pad mounting, the compression strength of the pad must be at least 4000 psi as determined by ASTM C39 test of compression strength of concrete cylinders.</b></p> <p><b>The slump of the concrete shall be 2” to 4” as determined by ASTM C143 test method.</b></p>
--	----------------	--



**Figure 6 Mounting Hole Dimensions (in inches)**

**3.6.3 Mounting the CUBE on a Pad**

Six customer supplied corrosion resistant 1/2”-13 hex head bolts with anchors are required for mounting the CUBE to the concrete pad. Use the following steps to mount the CUBE.

1. Layout, drill, and set the 1/2”anchors per manufacturer’s recommendations. The embedment depth is not to exceed 3.5”. Use the gasket as a mounting hole location template. Remove the anchor bolts for later reuse.
2. Clean any debris from the concrete pad.
3. Install the gasket by positioning it on the pad so that it is underneath the bottom of the CUBE when the cabinet is installed. Line up the gasket so that the cutouts are in proper position around the conduit opening and over the anchor bolts as shown in Figure 7.
4. Open the battery compartment to allow access to mounting holes.
5. Ensure that the CUBE is parallel to the pad surface as it is placed onto the pad and that it aligns with the holes in the pad and the gasket. Dress the cable/conduit so that it aligns with the CUBE openings as it is lowered onto the pad.
6. Place the CUBE on the pad. Loosen the slings so that all the weight is on the pad. Check that the CUBE is properly aligned.
7. Secure the CUBE to the pad using the 1/2”-13 hex head bolts. Tighten all bolts securely.
8. To secure the CUBE to a steel grate platform, install 1/2” corrosion-resistant Grade 5 steel hardware through the cabinet and platform grate. Ensure that the bolts are long enough to extend past the nut on the bottom side of the platform grate. For all mounting applications, each bolted joint should have a minimum Ø1 inch fender washer on the inside of the cabinet (and underside of the platform grate for platform mounting) with a lock washer. The washer on the underside of the platform must be large enough to cover both adjacent bearing bars as shown in Figure 8.
9. Once the CUBE is secured, remove the slings and tagline. Replace any panels removed and close the battery or equipment compartment door.

**3.6.4 Mounting the CUBE on a CPAD**

First, follow the instructions that ship with the CPAD to ensure that the CPAD is securely installed in the ground. Then proceed to mount the CUBE on the CPAD. Six customer supplied, corrosion resistant, 1/2”-13, 2” long fully threaded hex head bolts are required for mounting the CUBE to the CPAD.

1. Clean any debris from the CPAD.
2. Open the battery compartment to allow access to mounting holes.
3. Ensure that the CUBE is parallel to the CPAD surface as it is placed onto the CPAD and that it aligns with the holes in the CPAD. Dress the cable/conduit so that it aligns with the CUBE openings as it is lowered onto the CPAD.
4. Place the CUBE on the CPAD. Loosen the slings so that all the weight is on the CPAD. Check that the CUBE is properly aligned.
5. Secure the CUBE to the CPAD using the 1/2”-13 hex head bolts. Tighten all bolts securely.
6. Once the CUBE is secured, remove the slings and tagline. Close the cabinet doors.

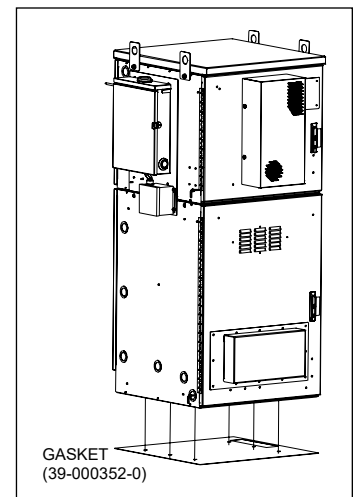

**Figure 7 Gasket Installation**

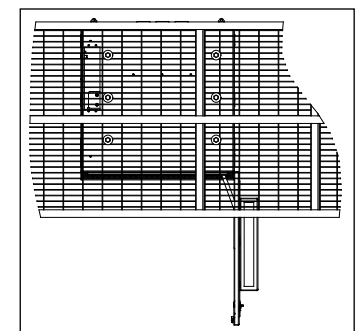

**Figure 8 Installing on a Platform**

### 3.7 CUBE Wiring and Equipment

After the CUBE is properly mounted in the desired location, apply No-Ox to all bus bar and other 2-hole lug connections. Install ground and power connections. Always ground the equipment first, before making any other connections.

	<b>WARNING</b>	<b>Perform all bonding and grounding connections prior to any electrical and communications connections.</b>
---	----------------	--

In order to prevent condensation prior to being placed in service, do not remove the desiccant until the CUBE is sealed and power is applied. Refer to supplemental documents for electrical diagrams for each CUBE.

#### 3.7.1 Ground Connections

Use the 2x8 position ground bars provided in the equipment compartment for grounding all internal equipment. Use the threaded studs available on the rear toward the bottom of the cabinet for connecting a site ground wire.

#### 3.7.2 AC Voltage Connections

The installer connects the two hot (line) wires to the breaker, the neutral wire to the neutral bus and the ground wire to the ground bus of the AC load center (if equipped). Use wire that is sized per National Electrical Code NFPA70 table 310.16.

#### 3.7.3 Battery Connections

	<b>WARNING</b>	<b>Always turn off battery breakers or disconnect blue Anderson connectors prior to servicing batteries. Disregard the (+) and (-) polarity markings on the blue Anderson connectors. The cable assemblies are used on both +24VDC and -48VDC products, so markings on the Anderson connectors are misleading.</b>
---	----------------	--

Verify the polarity of the cables prior to terminating them to the batteries. Ensure the battery terminations are properly insulated to avoid shorting prior to terminating to the batteries.

1. Disconnect the Anderson connector(s) or switch off the battery breaker located in the battery compartment.
2. Remove the battery retainer bracket by removing the hardware. Use the optional Charles 97-002145-A temporary shelf to allow easier disconnection of interconnecting straps. The shelf attaches to CUBE in front of the battery tray. Installers can then slide the batteries from the battery tray onto the shelf, disconnect the interconnecting straps, and remove the batteries (kit not compatible with slide-out battery trays).
3. If replacing batteries, disconnect battery cables from terminals and loosen the battery retaining strap(s).
4. Remove the interconnecting straps from the batteries. Remove batteries.
5. Carefully position the new batteries on the battery tray or temporary shelf. Connect the interconnecting straps to each battery string. If using the 97-002145-A temporary shelf, then slide the batteries onto the battery tray once the connection is complete. Remove the shelf.
6. Connect the battery cables to the appropriate terminals.
7. Secure the battery retaining straps and reinstall the battery retainer brackets using hardware from step 2.
8. Properly manage the battery cables.
  - Ensure that the bending radius does not exceed 5x the cable diameter (e.g. 4/0 battery cable = 4 inch bend radius).
  - Use as few bends as possible between the two termination points.
  - Do not bend the cable at the termination points.
9. Reconnect the Anderson connector(s) or switch on the battery breaker.

Notes:

- If using Anderson connectors, then all battery strings are terminated to the bus bars on the right side. The top bus bar is the power bus for -48VDC or +24VDC cabinets. The bottom bus bar is used for the return voltage. The bus bars have covers and use 1/4"-20 hex bolts for securing connections. If using battery breakers, then batteries are terminated at the power shelf.
- NiCd batteries require nickel plated lugs. Charles cables are equipped with the correct nickel plating.
- Ensure back up battery amperage is inputted into the power system controller per power system guidelines.
- Ensure float voltage is set per power system and battery guidelines.
- Ensure all battery terminations and bus bars have No Ox applied.
- Refer to the battery manufacturer's documentation for proper battery installation and maintenance information.

#### 3.7.4 Fiber and Copper Entry

There are multiple Ø1.75"/2.5" knockouts used for cable entry. There is also a cutout panel with four knockouts on the bottom of the CUBE. The Ø1.75" knockouts accommodate Ø1.25" conduit fittings, and the Ø2.5" knockouts accommodate Ø2.0" conduit fittings. Refer to Figure 2 for their locations.

**3.7.5 Overheat Thermostat**

The CUBE is equipped with an overheat (high temperature) alarm thermostat in the equipment and in the battery compartments. These overheat thermostats are wired in series and provide a normally closed connection. The equipment compartment overheat alarm is set for 60°C. The battery compartment overheat alarm is set for 60°C in units with DAC or 35°C in units with TEC. Either alarm will open the connection if its temperature set point is exceeded.

-NOTE-

*Changing the overheat (high-temp) thermostat default factory set points can lead to unnecessary alarms or system performance issues, such as equipment failures as a result of unreported alarms.*

**3.7.6 Alarm Block Connections**

A 10-position, labeled alarm block monitors components in the equipment compartment. See the electrical diagram for information about alarm connections. All alarm connections are normally closed and will open upon alarm.

**3.7.7 Masterlock Provision**

The cabinet has provisions for an optional Masterlock locking device. There are two kits necessary to complete a Masterlock cabinet door lock installation for an online system: a Network Controller kit (Charles 96-MLNTWKCTR-A) and a door kit. The door kit part number contains a door code and a region code (96-MLXDRX-XXX). Contact Charles for the appropriate part number for the installation. Refer to the documentation supplied with the Masterlock locking device for installation and use instructions.

**3.8 Conduit Seals**

All conduit openings on the CUBE must be completely sealed with a duct seal compound to prevent moisture from entering the CUBE. Use a moldable, flame-retardant putty style duct seal material. Do not use an expanding foam seal. Mold the putty so that the open space around the wire or conduit is completely sealed, as shown in Figure 9. If the openings must be accessed at any time, remove the putty and set it aside. When work is complete, re-mold the putty to re-seal the opening.

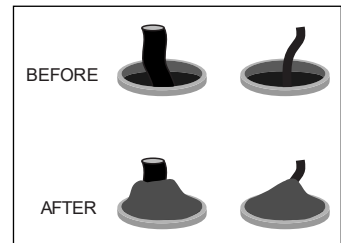

**Figure 9 Applying Putty Seal**

**3.9 Verifying the Installation**

Verify that the earth ground and all grounding and bonding are complete and functional. After verifying that all installer connections are secure and complete, connect power to the CUBE.

**4. PERIODIC MAINTENANCE**

In the event that the enclosure needs to be opened in freezing conditions, a narrow, blunt, metallic object such as a screwdriver or chisel, along with a non-metallic device such as a rubber mallet may be used to remove excessive ice build-up around the door and locking mechanism. A commercial aerosol de-icer spray can be used to free up locks and latches if needed.

Periodic cleaning of the filter screens is important to maintain proper ventilation. To clean the filter screens, remove the four nuts on each screen and take out the screens. Use a soft brush or hose to remove any debris from the screen. Once clean, replace the screens using the four nuts removed previously.

Reset the GFCI duplex receptacle periodically to ensure it is working. The unit meets UL-943, which requires an auto-monitoring (self-testing) feature. A flashing or solid red LED indicates a fault. If the unit continues to show a fault after resetting, replace the unit.

The heat exchanger (if equipped) requires no scheduled maintenance other than cleaning of the fans and the heat exchanger core if they become contaminated with dust or residue. Remove the cover by removing the screws on the outside. Examine periodically to determine the required cleaning periods based on the installed environmental conditions.

**5. TECHNICAL ASSISTANCE AND REPAIR SERVICE**

For questions on product repair or if technical assistance is required, contact Charles Technical Support.

847-806-8500  
[techserv@charlesindustries.com](mailto:techserv@charlesindustries.com) (email)  
<http://www.charlesindustries.com/techserv.htm>



## 6. WARRANTY & CUSTOMER SERVICE

Charles Industries, Ltd. offers a one-year warranty on the CUBE product. The Charles warranty is limited to the operation of the CUBE hardware as described in this documentation and does not cover equipment which may be integrated by a third party. The terms and conditions applicable to any specific sale of product shall be defined in the resulting sales contract. For questions on warranty or other customer service assistance, contact your Charles Customer Service Representative.

847-806-6300

[mktserv@charlesindustries.com](mailto:mktserv@charlesindustries.com) (email)

[http://www.charlesindustries.com/main/telecom\\_sales\\_support.htm](http://www.charlesindustries.com/main/telecom_sales_support.htm)

## 7. SPECIFICATIONS

### 7.1 Regulatory Specifications

- Designed to meet GR-487
- UL-60950 recognized
- GFCI: UL-943 listed

If CUBEs are field-modified, a customer provided ETL field evaluation of the modified components may be required to re-establish ETL certification to UL standards. Consult local jurisdictions for guidance on a site-by-site basis.

### 7.2 Product Specifications

<b>Physical</b>	
Dimensions	74"Hx32"Wx32"D (with no load center or thermal systems)
Equipment Rack Space and Hole Spacing	26.25" (15RU) rack spacing with tapped EIA #12-24 mounting holes
Battery Tray Size	12.75"Hx21"Wx27"D
Materials: Cabinet Battery Trays	.125 aluminum 10GA steel
Color	Off-white
Covered Bus Bar	2-hole on .625" spacing with 1/4"-20 threaded holes and hex-head screws
<b>Electrical</b>	
Bonding and Grounding	Two 2x8-position ground bars in equipment compartment
Supported Batteries	See Table 3
<b>Environmental</b>	
Operating Temp. Range, Outside Enclosure	-40° to +115°F, -40° to 46°C
Operating Temp Range, Inside Enclosure	-40° to +149°F, -40° to 65°C
Humidity	0 to 95% (non-condensing)
Altitude	Up to 2,000 meters (6560 feet)
<b>Kits and Replacement Parts</b>	
Replacement Gasket	39-000352-0
Touch-up Paint	02-000290-0
216 Type Security Tool	07-002070-0
Shim Kit for Leveling	97-000010-0
Swing Handle	39-000148-0
1/4 Turn Latch with Padlock Hasp	39-000311-0
1/4 Turn Latch	39-000269-0
4-Wire Door Alarm Switch (Black)	17-400319-0
15A GFCI Outlet	04-100207-0
Overheat Thermostat	99-004548-0

**Table 1 CUBE Specifications (all models)**

### 7.3 CUBE Models and Individual Specifications

Part Number	Thermal System	Battery Strings	AC Load Center	Power System
SS4C215DB1	750W heat exchanger, DAC for batteries	3 strings, -48VDC	12 position	None
SS4C215DB3	750W heat exchanger, DAC for batteries	3 strings, -48VDC	12 position	-48/+24VDC
SS4C215DB4	750W heat exchanger, DAC for batteries	3 strings, -48VDC	12 position	-48VDC
SS4C215DN1	750W heat exchanger, DAC for batteries	3 strings, -48VDC	None	None
SS4C215XN1	(2) 750W heat exchanger, 200W TEC for batteries	3 strings, -48VDC	None	None

**Table 2 CUBE Models and Individual Specifications**

### 7.4 Supported Batteries

Manufacturer	Model Number	Amp Hours
Northstar	NSB110FT	110
Northstar	NSB155FT	155
Northstar	NSB170FT	170
Energys	SBS112F	112
Energys	SBS170F	170
Energys	SBS190F	190
C&D	TEL12-155FNG	115
C&D	TEL12-155F	155
C&D	TLE12-170F	170
C&D	TEL12-190F	190
C&D	Tel12-210F	210
GNB Marathon	M12V125FT	125
GNB Marathon	M12V155FT	155
GNB Marathon	M12V180FT	180
Saft	Tel.X 150 (P/N 80-94691-02)	150
Saft	Tel.X 180 (P/N 80-94693-02)	180
Saft	Tel.X 180 (P/N 80-94865-02)	180
East Penn Deka	12AVR-150ET	150
East Penn Deka	12AVR-170ET	170

**Table 3 CUBE Supported Batteries**