

Charles Universal Broadband Enclosure

CUBE-SS4C228PX1

General Description and Installation

1. GENERAL INTRODUCTION	1
1.1. Document Purpose	1
2. PRODUCT DESCRIPTION	1
3. CUBE WIRING AND EQUIPMENT.....	3
3.1. HVAC Operation	4
3.2. TEC Operation	4
3.3. Alarm Terminal Panel.....	4
4. SPECIFICATIONS.....	4

1. GENERAL INTRODUCTION

1.1. Document Purpose

This document provides additional information for the CUBE-SS4C228PX1 of the Charles Industries' Universal Broadband Enclosure (CUBE) product line that is not included in the family document, LT-SSXX228XXX. Figure 1 shows a closed front view of the enclosure.

-NOTE-

Hereafter, the CUBE-SS4C228PX1 Charles Universal Broadband Enclosure will be referred to as the "CUBE."

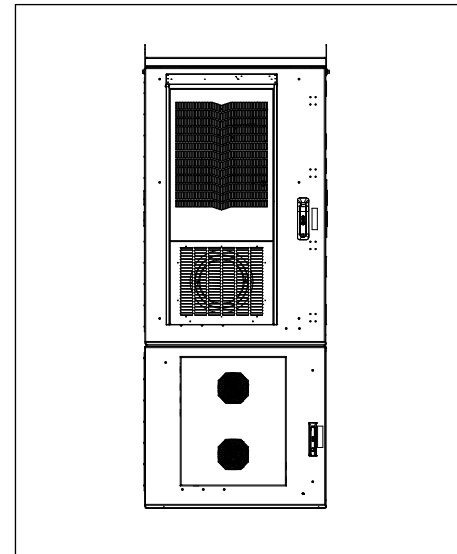

Figure 1 Front View of the CUBE

2. PRODUCT DESCRIPTION

The equipment compartment includes a 2250W 48VDC thermosiphon. The battery compartment supports three strings of -48VDC VRLA batteries (customer supplied), and it is equipped with a -48VDC thermoelectric cooling system (TEC). Figure 2 shows the components of the CUBE.

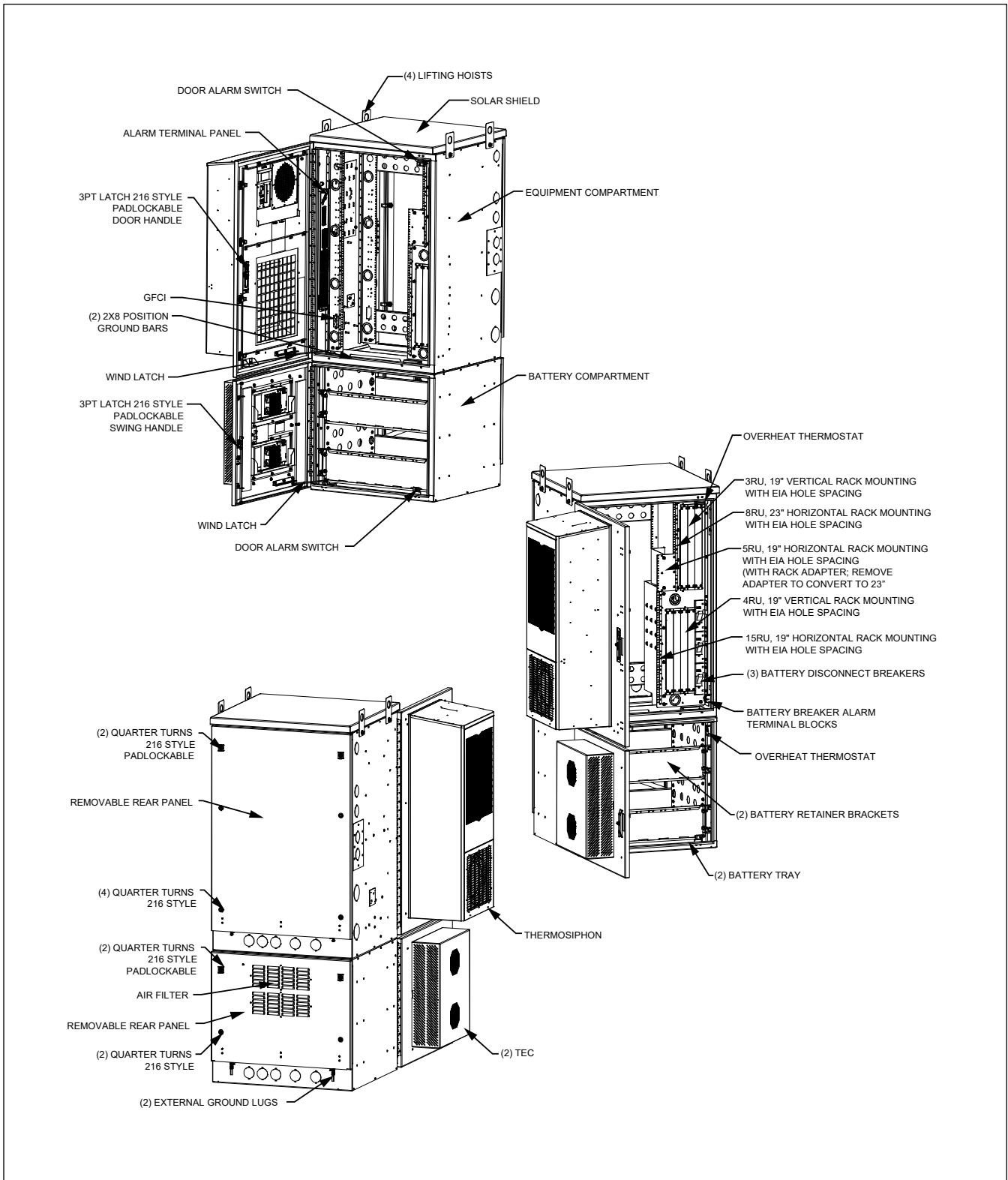

Figure 2 CUBE Components

3. CUBE WIRING AND EQUIPMENT

After the CUBE is properly mounted in the desired location, apply No-Ox where bus bar and other 2-hole lug connections will be made. Install ground and power connections. Always ground the equipment first, before making any other connections.

	WARNING	Perform all bonding and grounding connections prior to any electrical and communications connections.
--	----------------	--

In order to prevent condensation prior to being placed in service, do not remove the desiccant until power is applied to the CUBE. A basic electrical diagram is shown in Figure 3.

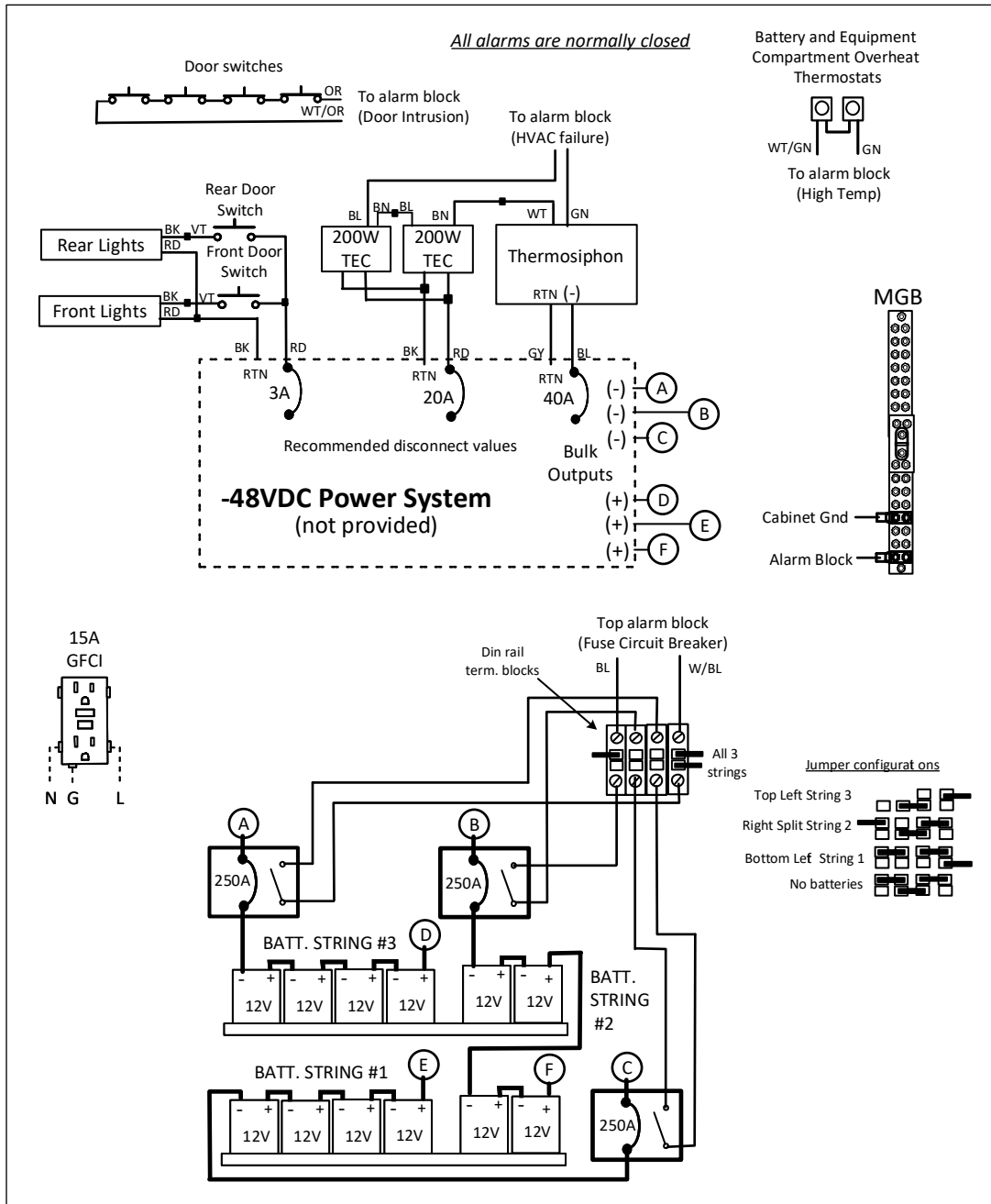

Figure 3 CUBE Electrical Diagram

3.1. Thermosiphon Operation

The DC powered thermosiphon in the equipment compartment has a speed controller and includes an internal and an external fan. The fans' speed increases with increasing ambient temperature. Fan settings are defined below.

Fan Setting	Internal	External
Turn-on Setting	-40°C	35°C
Medium Temp Setting	35°C	35°C
High Temp Setting	45°C	45°C

For more information, refer to the thermosiphon documentation found inside the CUBE.

-NOTE-

Changing the speed controller default factory set points can lead to system performance issues, such as equipment failures, increased power use, unnecessary alarms, noise, condensation build up, fan failure caused by excessive runtimes and vibration. Avoid placing items in front of the thermosiphon's return and supply vents. Maintain a minimum of 6" clearance to enable proper air flow.

3.2. TEC Operation

The TEC devices mounted on the door of the battery compartment are covered by an external shroud. On-board controllers allow both heating and cooling cycles. The cooling cycle turns on at 25°C and turns off at 20°C. The heating cycle turns on at 5°C and turns off at 10°C. Condensation build up on the heat sink of the TEC is normal.

The TEC has a built in low voltage disconnect that sends the unit into an idle state in order to extend battery life for customer loads when AC power is lost. The unit enters idle mode when the input voltage drops to 50.5VDC (±1VDC) and remains idle until the voltage reaches 52.25VDC (±0.75VDC). For more information, refer to the TEC documentation found inside the CUBE.

-NOTE-

It is not possible to change any of the TEC factory default set points.

3.3. Alarm Terminal Panel

All alarm wiring is connected to the 40-position alarm panel. Refer to the family practice LT-SSxx228xxx for more information about the panel. The following table shows the macro alarm block wiring for this unit.

Alarm ID	Color	POS	Color	POS2
Door Intrusion	ORG	CC1	WHT/ORG	RET1
HVAC Failure	BLU	CC12	WHT	RET12
High Temp	GRN	CC13	WHT/GRN	RET13
Battery Breaker Alarm	BLU	CC23	BLU/WHT	RET23

4. SPECIFICATIONS

Physical	
Weight	Approx. 770 lbs. as shipped
Electrical	
Battery Disconnect Breakers	18-908176-0
Thermal	
Thermosiphon	2250W, Vikinor VHT-225-DC
Maximum Heat Dissipation	2090W@19°C above ambient with solar
TEC	200W, 48VDC, Delta Products, HET200PB-007

Table 1 CUBE Specifications (see family documentation for full list)