

# Charles Universal Broadband Enclosure

## CUBE-RL22021QE2

### General Description and Installation

|   |          |
|---|----------|
| <b>1. GENERAL INTRODUCTION .....</b>                    | <b>1</b> |
| 1.1. Document Purpose .....                             | 1        |
| 1.2. Product Purpose .....                              | 1        |
| 1.3. Product Mounting and Location .....                | 1        |
| <b>2. PRODUCT DESCRIPTION .....</b>                     | <b>2</b> |
| <b>3. INSTALLATION .....</b>                            | <b>4</b> |
| 3.1. Inspecting the Product .....                       | 4        |
| 3.2. Following and Using Safety Precautions .....       | 4        |
| 3.3. Obtaining Tools and Equipment .....                | 4        |
| 3.4. Preparing the Installation Site .....              | 4        |
| 3.5. Lifting the CUBE .....                             | 5        |
| 3.6. Mounting the CUBE .....                            | 5        |
| 3.7. CUBE Wiring and Equipment .....                    | 6        |
| 3.8. Conduit Seals .....                                | 8        |
| 3.9. Verifying the Installation .....                   | 8        |
| <b>4. PERIODIC MAINTENANCE .....</b>                    | <b>8</b> |
| <b>5. TECHNICAL ASSISTANCE AND REPAIR SERVICE .....</b> | <b>8</b> |
| <b>6. WARRANTY &amp; CUSTOMER SERVICE .....</b>         | <b>9</b> |
| <b>7. SPECIFICATIONS .....</b>                          | <b>9</b> |
| 7.1. Regulatory Specifications .....                    | 9        |
| 7.2. Product Specifications .....                       | 9        |

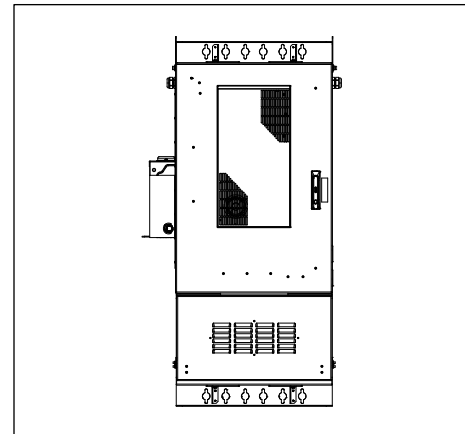

**Figure 1 Front View of the CUBE**

## 1. GENERAL INTRODUCTION

### 1.1. Document Purpose

This document provides general information for the CUBE-RL22021QE2 of the Charles Industries' Universal Broadband Enclosure (CUBE) product line. Figure 1 shows a closed front view of the enclosure.

-NOTE-

*Hereafter, the Charles Universal Broadband Enclosure CUBE-RL22021QE2 will be referred to as the "CUBE."*

### 1.2. Product Purpose

The CUBE consists of a protective enclosure for an integrated system of electronic components and equipment that can serve fiber and copper interfaces.

### 1.3. Product Mounting and Location

This enclosure is suitable for outside plant-type (OSP) locations and those that may require NEC compliance. The outdoor, weather-resistant CUBE is to be mounted on a pad, wall, pole, or H-frame. The installer connects the power, fiber and copper connections. Detailed mounting and installation information is covered in Section 3.

## 2. PRODUCT DESCRIPTION

The CUBE has an equipment compartment and a battery compartment. The equipment compartment has 20RU of 19" horizontal rack spacing, an 8-position AC load center, and a 750W DC powered heat exchanger. The battery compartment supports one string of customer supplied -48VDC Saft Tel.X 80 or Saft Tel.X 100 NiCd batteries.

Figure 2 shows the CUBE dimensions and Figure 3 shows the main components of the CUBE.

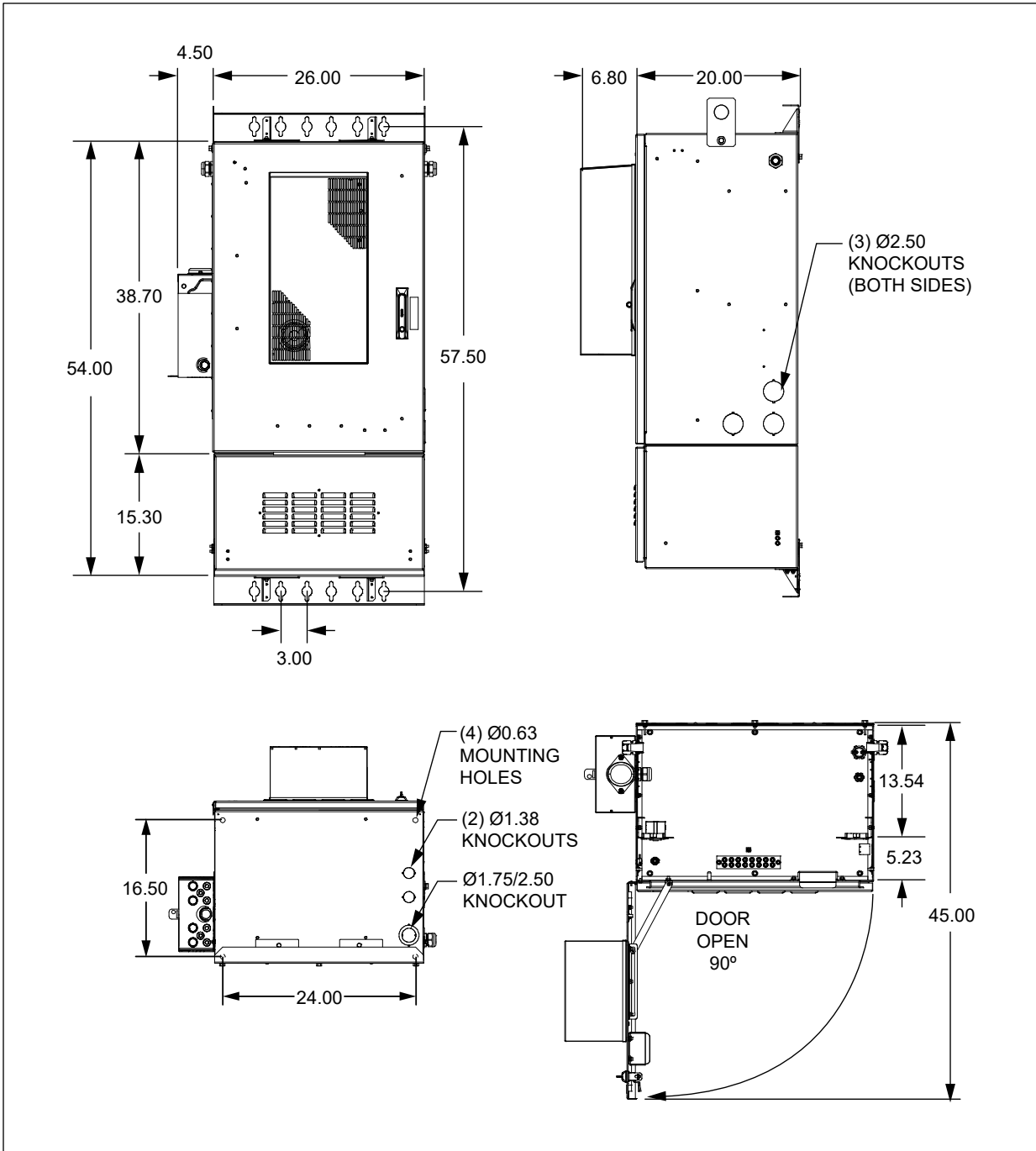
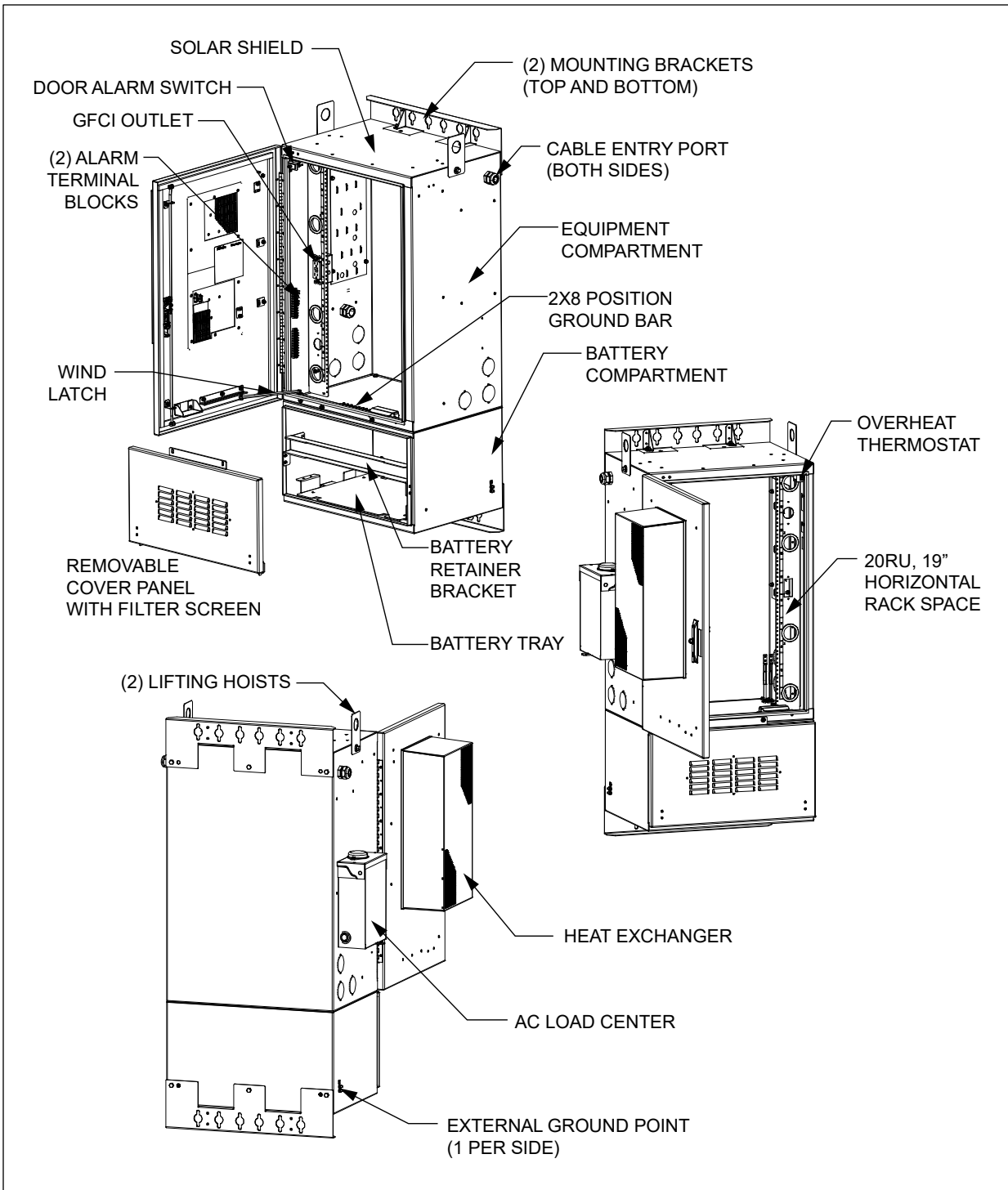

Figure 2 CUBE Dimensions (in inches)



**Figure 3 CUBE Components**

### 3. INSTALLATION

#### 3.1. Inspecting the Product

The CUBE is shipped mounted upright on a skid. Remove the bolts, unpack the unit, and dispose of the packaging material.

*-INSPECTION NOTE-*

*Visually inspect the unit for damages prior to installation. If the equipment was damaged in transit, immediately report the extent of the damage to the transportation company.*

#### 3.2. Following and Using Safety Precautions

Read the following site and safety tips, cautions, and warnings, then proceed with the paragraphs that follow.

- For installation, follow all National Electrical Codes (NEC) ANSI/NFPA 70, local, environmental, workplace, and company codes, safety procedures, and practices.
- Minimum spacing between the accessories and components and the housing for ITE equipment shall be maintained for safe operation of the equipment when installed in accordance with NEC ANSI/NFPA 70.
- Read all instructions, warnings and cautions on the equipment and in the documentation shipped with the product.
- Always connect ground connections first.
- Do not place this product on weak or unstable surfaces which may allow the product to fall, resulting in potentially serious damage(s) to persons or product.
- Only authorized trained personnel shall install the CUBE.
- In windy conditions, be sure to engage the door latches to secure the door in a stationary position.

#### 3.3. Obtaining Tools and Equipment

Obtain the following recommended or needed items for installing the CUBE.

- Sufficient length and quantities of fiber cable (or pigtails)
- Cable, tube, wire, and fiber cleaning materials
- Protective and/or insulated work gloves
- Safety glasses
- Tape measure
- Marking utensil
- #6 ground wire or rod and earth ground materials
- Bond strap (optional, from cable bond clamp to bond post)
- Any exterior cable strain relief, per company practice
- Slotted, hex, and Phillips screwdrivers
- Torque wrench
- Assorted cable ties, clips, or fasteners (optional)
- Can wrench (216 type tool)
- Derrick for lifting
- Level

#### 3.4. Preparing the Installation Site

Observe the following site preparation recommendations.

- Leave adequate horizontal and vertical space between multiple installations to allow for proper cable access, as well as enough room around the enclosure to open the door(s).
- The site must meet minimal personnel and equipment safety requirements.
- The distance from the cable entry point should be consistent with local installation practices.
- The pad, wall, H-frame, or pole must be able to support the weight of the CUBE.
- Run all fiber and copper facilities to the site.

### 3.5. Lifting the CUBE

See Table 1 for CUBE weight. Charles recommends the following procedure for lifting the CUBE.

#### 3.5.1. Required Equipment

- One derrick (crane) capable of lifting the CUBE
- Spreader bar
- Two lifting slings or chains with each having a 2,500 lbs. capacity
- Connecting links to attach slings to the CUBE's lifting brackets
- 75-ft. long tagline rope

Insert the lifting sling connecting links securely through each of the lifting brackets as shown in Figure 4.

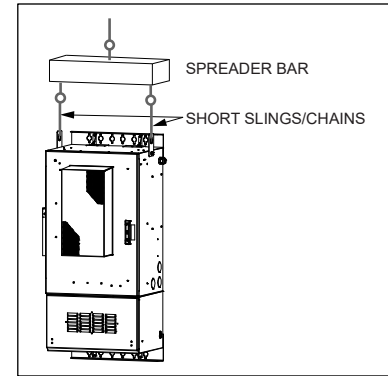

Figure 4 Lifting the CUBE

#### 3.5.2. Warnings and Specific Safety Precautions

|  |                |   |
|--|----------------|---|
|  | <b>WARNING</b> | <p><b>Improper hoisting equipment and unsafe lifting procedures can result in serious injury or death</b></p> <p><b>Because of the added risk of injury or damage, do not lift enclosures with batteries installed.</b></p> |
|--|----------------|---|

Observe the following local safety procedures when performing the tasks in this section.

- Keep the CUBE away from any power lines.
- Keep bystanders away from the work operations at all times.
- Only trained operators shall operate the crane for lifting and setting the CUBE.
- Do not suspend loads over people or equipment.
- All persons working with hoisting equipment shall wear standard safety gear according to local practices including safety helmets and steel-toed shoes.
- Do not operate the hoisting equipment until all stabilizer are extended and in firm contact with the ground or adequate support structure.
- Do not attempt to retract or extend the stabilizers while a load is suspended.

### 3.6. Mounting the CUBE

Charles recommends using a minimum SAE Grade 2 corrosion-resistant bolts, washers, and nuts for all mounting applications. Bolts need to be of sufficient length depending on which type of mounting is used. Use 3/8" diameter bolts for wall, pole, and H-frame mounting, and use 1/2" diameter bolts for pad mounting.

The CUBE ships with the mounting brackets facing toward the center. For wall, H-frame, or pole mounting, reorient the brackets prior to mounting as shown in Figure 2, and torque the mounting bracket screws to a value of 180 in-lbs.

A minimum of 3/4" thick plywood or similar surface is required for wall mounting

Charles kit 97-CABPMTKIT is available for pole-mount applications.

Charles kit 97-001971-A contains hardware for mounting to H-frame unistruts.

Charles kit 97-002176-A is available for mounting the CUBE to a pad.

#### 3.6.1. Torque Requirements

Torque all hardware as shown below (unless otherwise noted). These values apply to SAE Grade 1 & 2 Low Carbon Steel, ASTM A307 Low Carbon Steel, and Stainless Steel Grade 18-8.

| Thread Size | In-lbs  | Ft-lbs  |
|-------------|---------|---------|
| 4-40        | 4±10%   |         |
| 6-32        | 8±10%   |         |
| 8-32        | 16±10%  |         |
| 10-32       | 26±10%  |         |
| 12-24       | 50±10%  |         |
| 1/4-20/M6   | 60±5%   | 5±5%    |
| 5/16-18     | 125±5%  | 10.4±5% |
| 3/8-16      | 180±5%  | 15.0±5% |
| 1/2-13      | 500±2%  | 41.7±2% |
| 5/8-11      | 1000±1% | 83.3±1% |

### 3.7. CUBE Wiring and Equipment

After the CUBE is properly mounted in the desired location, apply No-Ox where bus bar and other 2-hole lug connections will be made. Install ground and power connections. Always ground the equipment first, before making any other connections.

|  |                |  |
|--|----------------|--|
|  | <b>WARNING</b> | <b>Perform all bonding and grounding connections prior to any electrical and communications connections.</b> |
|--|----------------|--|

In order to prevent condensation prior to being placed in service, do not remove the desiccant until the CUBE is sealed and power is applied. A basic electrical diagram is shown in Figure 5.

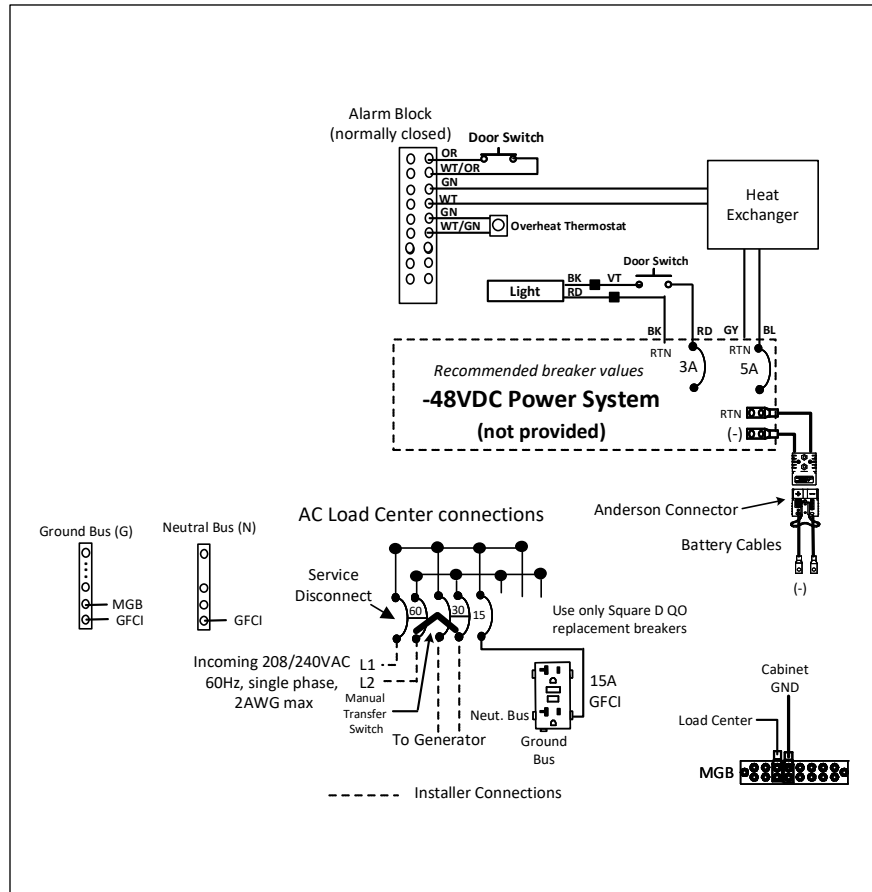

Figure 5 Electrical Diagram

#### 3.7.1. Ground Connection

Use the 2x8 position ground bar provided in the equipment compartment for all grounding of internal equipment. Stack hardware as shown in Figure 6. Use the two external two-conductor ground studs, one on the left side of the cabinet and one on the right, near the bottom, for connecting a site ground wire.

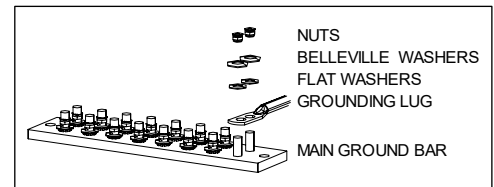



Figure 6 Ground Bar Hardware Stack

**3.7.2. AC Voltage Connection**

The incoming AC voltage is a single phase 208/240V at 60Hz and is connected to the 60A main circuit breaker in the 8-position AC load center. The maximum wire size is 2 AWG. The installer connects the two hot (line) wires to the breaker, the neutral wire to the neutral bus and the ground wire to the ground bus. Use wire that is sized per National Electrical Code NFPA70 table 310.16. A 15A circuit breaker is used for the GFCI outlet.

**3.7.3. Battery Connection**

|   |                |  |
|---|----------------|--|
|  | <b>WARNING</b> | <p><b>Always disconnect Anderson connectors prior to servicing batteries.</b></p> <p><b>Disregard the (+) and (-) polarity markings on the Anderson connectors. The cable assemblies are used on both +24VDC and -48VDC products, so markings on the Anderson connectors are misleading.</b></p> |
|---|----------------|--|

Verify the polarity of the cables prior to terminating them to the batteries. Ensure the battery terminations are properly insulated to avoid shorting prior to terminating to the batteries.

1. Disconnect the Anderson connector(s) located in the battery compartment.
2. Open the equipment compartment door, remove the two screws at the top of the battery compartment, and slide the cover off. Remove the battery retainer bracket from the front and loosen the provided battery straps.
3. If replacing batteries, disconnect battery cables from terminals and loosen the battery retaining strap(s).
4. Remove the interconnecting straps from the batteries. Remove batteries.
5. Carefully position the new batteries on the battery tray. Connect the interconnecting straps to each battery string.
6. Connect the battery cables to the appropriate terminals.
7. Secure the battery retaining straps and reinstall the battery retainer brackets using hardware from step 2.
8. Properly manage the battery cables.
  - o Ensure that the bending radius does not exceed 5x the cable diameter (e.g. 4/0 battery cable = 4 inch bend radius).
  - o Use as few bends as possible between the two termination points.
  - o Do not bend the cable at the termination points.
9. Reconnect the Anderson connector(s).

Notes:

- Anderson connectors and battery breakers terminate at the power shelf.
- NiCd batteries require nickel plated lugs. Charles cables are equipped with the correct nickel plating.
- Ensure back up battery amperage is inputted into the power system controller per power system guidelines.
- Ensure float voltage is set per power system and battery guidelines.
- Ensure all battery terminations and bus bars have no ox applied.
- Refer to the battery manufacturer’s documentation for proper battery installation and maintenance information.

**3.7.4. Heat Exchanger Operation**

The 760W DC powered heat exchanger in the equipment compartment has a fan speed controller and includes an internal and an external fan. Both fans’ speed increases with increasing internal cabinet temperature. Fans and heat exchanger settings are defined below, and are based off of the cabinet interior temperature. The maximum airflow amount supplied to the equipment by the heat exchanger is 147CFM.

| Setting                            | Internal | External |
|------------------------------------|----------|----------|
| Turn-on Setting (5°C Differential) | 0°C      | 30°C     |
| Medium Temp Setting                | 30°C     | 35°C     |
| High Temp Setting                  | 45°C     | 50°C     |
| High Temp Alarm Setting            | 70°C     | N/A      |
| Low Temp Alarm Setting             | -40°C    | N/A      |

For more information, refer to the heat exchanger documentation found inside the CUBE.

|   |
|---|
| <p><i>-NOTE-</i></p> <p><i>Changing the speed controller default factory set points can lead to system performance issues, such as equipment failures, increased power use, unnecessary alarms, noise, condensation build up, fan failure caused by excessive runtimes and vibration.</i></p> <p><i>Avoid placing items in front of the heat exchanger’s return and supply vents. Maintain a minimum of 6” clearance to enable proper air flow.</i></p> |
|---|

**3.7.5. Overheat Thermostat**

The CUBE is equipped with an overheat (high temperature) alarm thermostat in the equipment compartment that provides a normally closed connection. The overheat alarm is factory set at 60°C and opens the connection if this temperature is exceeded.

-NOTE-

*Changing the overheat (high-temp) thermostat default factory set points can lead to unnecessary alarms or system performance issues, such as equipment failures as a result of unreported alarms.*

**3.7.6. Alarm Block Connections**

Two 10-position, labeled alarm blocks monitor components in the equipment compartment. See the electrical diagram for information about alarm connections. All connections are normally closed and will open upon alarm.

**3.7.7. Fiber and Copper Entry**

The CUBE has three Ø2.50” knockouts on each side that accommodate Ø2.00” conduit fittings, as well as on cord grip fitting on each side. The bottom panel has two Ø1.38” knockouts that accommodate Ø1.00” fittings and one Ø1.75/2.50” knockout that accommodates Ø1.25/2.50” fittings. See Figure 2 for cable entry locations.

**3.8. Conduit Seals**

All internal and external conduit openings on the CUBE must be completely sealed with a duct seal compound to prevent moisture from entering the equipment compartment. The battery compartment must be internally sealed from the equipment compartment to prevent outgassing from the batteries into the equipment compartment. Use a moldable, flame-retardant putty style duct seal material. Do not use an expanding foam seal. Mold the putty so that the open space around the wire or conduit is completely sealed, as shown in Figure 8. If the openings must be accessed at any time, remove the putty and set it aside. When work is complete, re-mold the putty to re-seal the opening.

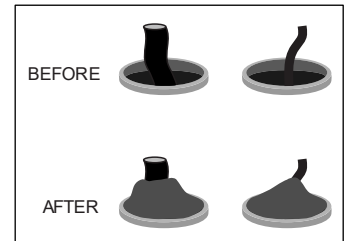

**Figure 8 Applying Putty Seal**

**3.9. Verifying the Installation**

Verify that earth ground and all grounding and bonding is complete and functional. After verifying that all installer connections are secure and complete, apply voltage.

**4. PERIODIC MAINTENANCE**

In the event that the enclosure must be opened in freezing conditions, use a narrow, pointed metallic object such as a screwdriver or chisel, along with a non-metallic device like a rubber mallet, to remove excessive ice buildup around the door and locking mechanism. A commercial aerosol de-icer spray can be used to free up locks and latches if needed. Use protective gloves and safety glasses when applying de-icer sprays.

Periodic cleaning of the filter screens is important to maintain proper ventilation. To clean the filter screens, remove the four nuts on each screen and take out the screens. Use a soft brush or hose to remove any debris from the screen. Once clean, replace the screens using the four nuts removed previously.

Reset the GFCI duplex receptacle periodically to ensure it is working. The unit meets UL-943, which requires an auto-monitoring (self-testing) feature. A flashing or solid red LED indicates a fault. If the unit continues to show a fault after resetting, replace the unit.

The heat exchanger requires no scheduled maintenance other than cleaning the fans and heat exchanger core if they become contaminated with dust or residue. Remove the cover by removing the screws on the outside. Examine periodically to determine the required cleaning periods based on the installed environmental conditions.

**5. TECHNICAL ASSISTANCE AND REPAIR SERVICE**

For questions on product repair or if technical assistance is required, contact Charles Technical Support.

847-806-8500  
[techserv@charlesindustries.com](mailto:techserv@charlesindustries.com) (email)  
<http://www.charlesindustries.com/techserv.htm>



## 6. WARRANTY & CUSTOMER SERVICE

Charles Industries LLC offers a one-year warranty on the CUBE product. The Charles warranty is limited to the operation of the CUBE hardware as described in this documentation and does not cover equipment which may be integrated by a third party. The terms and conditions applicable to any specific sale of product shall be defined in the resulting sales contract. For questions on warranty or other customer service assistance, contact your Charles Customer Service Representative.

847-806-6300

[mktserv@charlesindustries.com](mailto:mktserv@charlesindustries.com) (email)

[http://www.charlesindustries.com/main/telecom\\_sales\\_support.htm](http://www.charlesindustries.com/main/telecom_sales_support.htm)

## 7. SPECIFICATIONS

### 7.1. Regulatory Specifications

- Designed to meet GR-487
- GFCI: UL-943 Listed

If CUBE's are field-modified, a customer provided ETL field evaluation of the modified components may be required to re-establish ETL certification to UL standards. Consult local jurisdictions for guidance on a site-by-site basis.

### 7.2. Product Specifications

| <b>Physical</b>                           |   |
|---|---|
| Dimensions                                | 54"Hx26"Wx20"D  |
| Weight                                    | Approx. 190 lbs. as shipped   |
| 19" Equipment Rack Space and Hole Spacing | 35" (20RU) rack spacing with tapped EIA #12-24 mounting holes                             |
| Battery Tray Size                         | 13.20"Hx20.85"Wx15.66"D   |
| Maximum Supported Weight                  | Rack Rails: 220 lbs<br>Battery Tray: 1000 lbs.  |
| Materials                                 | 0.125" aluminum   |
| Color                                     | Off-white   |
| <b>Electrical</b>                         |   |
| AC Load Center                            | Square D QO816L100RB  |
| Supported Batteries                       | Soft Tel.X 80 (80-94690-02) or Soft Tel.X 100 (80-94692-02)                               |
| Bonding and Grounding                     | One 2x8-position ground bar inside equipment compartment<br>Two external ground locations |
| Cable Entry                               | See Figure 2 and section 3.7.10   |
| <b>Thermal</b>                            |   |
| Heat Exchanger                            | 760W, 48VDC, Vikinor VHC-040-DC   |
| Maximum Heat Dissipation                  | 710W@19°C above ambient with solar  |
| <b>Environmental</b>                      |   |
| Operating Temp. Range, Outside Enclosure  | -40° to +115°F, -40° to 46°C  |
| Operating Temp Range, Inside Enclosure    | -40° to +149°F, -40° to 65°C  |
| Humidity                                  | 0 to 95% (non-condensing)   |
| Altitude                                  | Up to 2,000 meters (6560 feet)  |
| <b>Kits and Replacement Parts</b>         |   |
| Touch-up Paint                            | 02-000290-0   |
| 216 Type Security Tool                    | 07-002070-0   |
| Plinth Mounting Kit                       | 97-002176-A   |
| Pole Mounting Kit                         | 97-CABPMTKIT  |
| H-frame Hardware Kit                      | 97-001971-A   |
| Swing Handle                              | 39-000148-0   |
| 2-Wire Door Alarm Switch                  | 17-400314-0   |
| GFCI Outlet                               | 15A: 04-100207-0  |
| Overheat Thermostat                       | 99-004548-0   |

Table 1 CUBE Specifications