

Charles Universal Broadband Enclosure

CUBE-PM64412BN2

General Description and Installation

1. GENERAL INTRODUCTION	1
1.1. Document Purpose	1
2. PRODUCT DESCRIPTION	1
3. CUBE WIRING AND EQUIPMENT.....	3
3.1. HVAC Operation	4
3.2. Alarm Terminal Panel.....	4
4. SPECIFICATIONS.....	4

1. GENERAL INTRODUCTION

1.1. Document Purpose

This document provides additional information for the CUBE-PM64412BN2 of the Charles Industries' Universal Broadband Enclosure (CUBE) product line that is not included in the family document, LT-PM64412xxx. Figure 1 shows a closed front view of the enclosure.

-NOTE-

Hereafter, the Charles Universal Broadband Enclosure CUBE-PM64412BN2 will be referred to as the "CUBE."

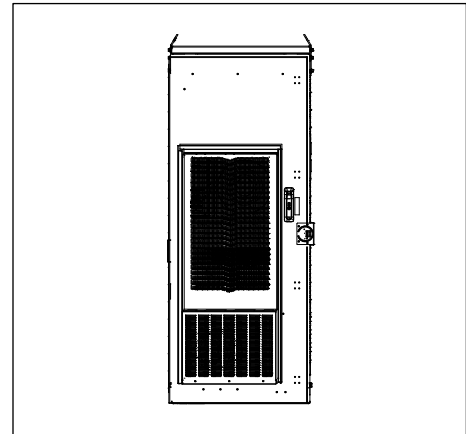

Figure 1 Front View of the CUBE

2. PRODUCT DESCRIPTION

The CUBE includes two 17000BTU DC powered HVAC systems. Figure 3 shows the main components of the CUBE.

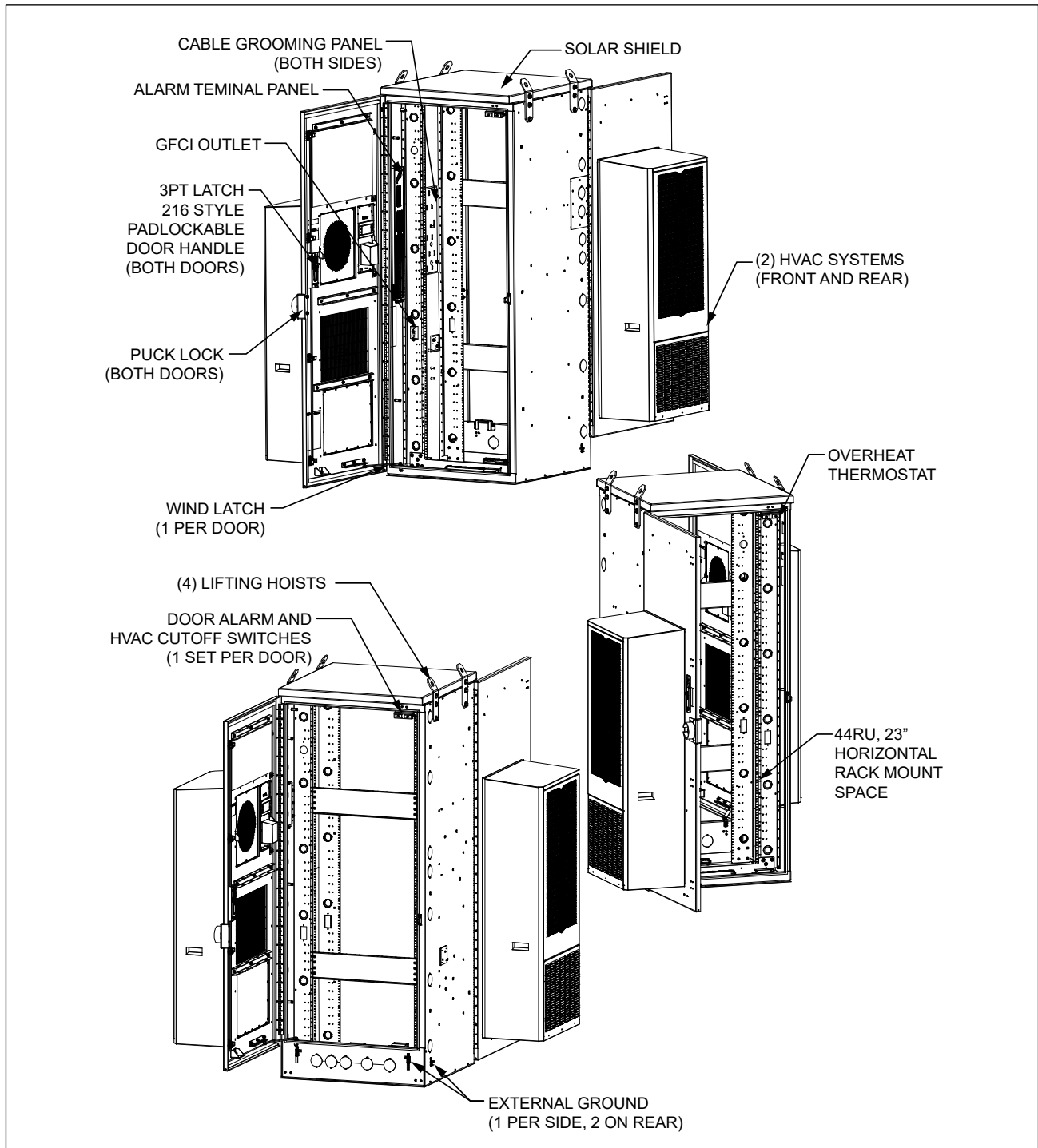

Figure 2 CUBE Components

3. CUBE WIRING AND EQUIPMENT

After the CUBE is properly mounted in the desired location, apply No-Ox where bus bar and other 2-hole lug connections will be made. Install ground and power connections. Always ground the equipment first, before making any other connections.

WARNING Perform all bonding and grounding connections prior to any electrical and communications connections.

In order to prevent condensation prior to being placed in service, do not remove the desiccant until the CUBE is sealed and power is applied. A basic electrical diagram is shown in Figure 3.

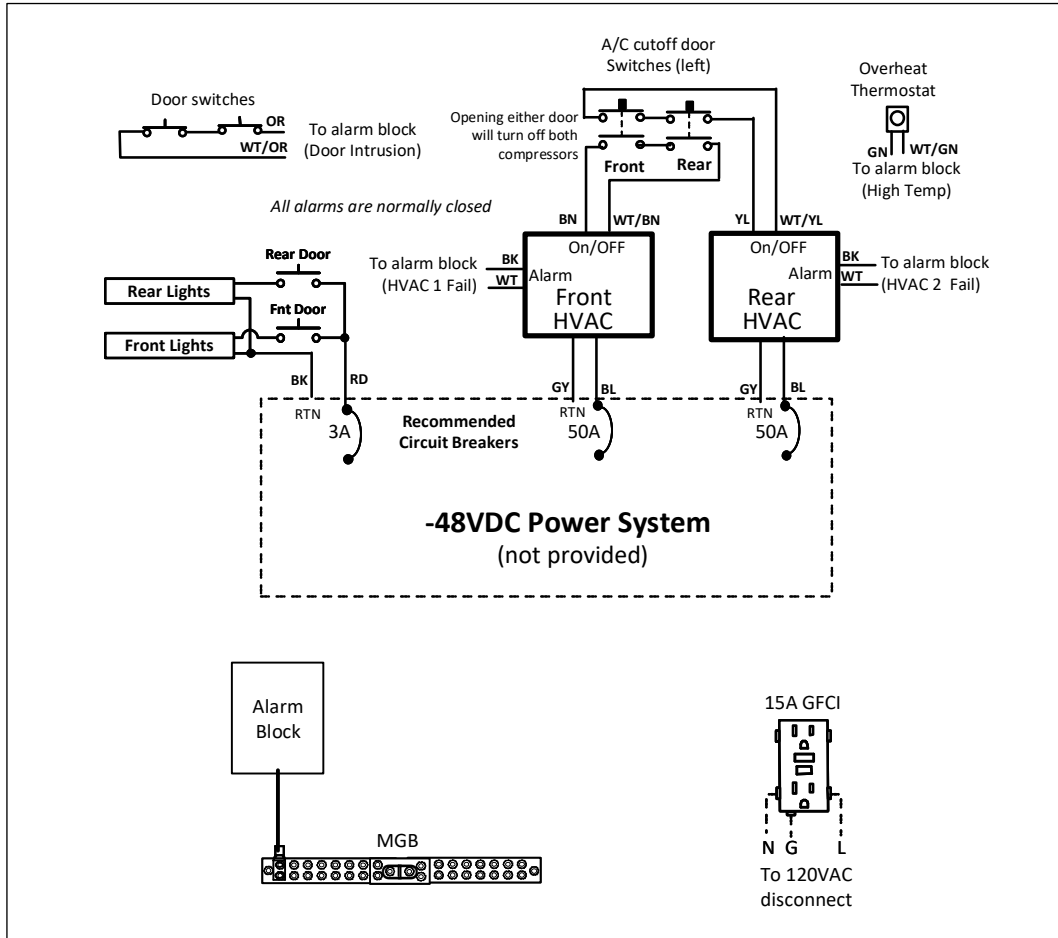

Figure 3 Electrical Diagram

3.1. HVAC Operation

The two 17,000BTU (5kW) DC powered HVAC compressors and fans are PID (proportional integral derivative) controlled. The front HVAC compressor turns on at the internal return temperature of 35°C at low speed and will increase/decrease speed as needed to maintain this temperature. The front HVAC compressor turns off when the return temperature reaches 30°C and after at least 3 minutes of running. The rear HVAC compressor turns on at 45°C and turns off at 40°C as it is used as a backup scenario only. The internal fans of both HVAC units are always on at low speed (30%) to continually circulate heat within the cabinet. The external fans of both units turn on/off along with their respective compressors. The speed of all fans increases/decreases as needed with changing internal cabinet temperature. In addition, both HVAC units include a built-in 1000W heater for cold temperature operation. HVAC settings for the compressor, fans, heater, and temperature alarms are defined below and are based off the HVAC’s interior return temperature. The CUBE is equipped with cutoff switches that shut off the HVAC compressors when a door is opened to minimize condensation buildup on the coils.

The maximum airflow amount supplied to the equipment by each HVAC is 824CFM. For further information, refer to the HVAC documentation that ships with the CUBE.

-NOTE-

Changing the cooling or heating cycles’ default factory set points can lead to system performance issues, such as equipment failures, increased power use, unnecessary alarms, noise, condensation build up, compressor or fan failure caused by excessive runtimes and vibration.

Avoid placing items in front of the HVAC’s return and supply vents. Maintain a minimum of 6” clearance to enable proper air flow.

HVAC Compressor/Fans/Heater/Alarms Setting	Internal, Front	External, Front	Internal, Rear	External, Rear
Compressor ON Setting	35°C	N/A	45°C	N/A
Compressor OFF Setting	30°C	N/A	40°C	N/A
Fan Turn-on Setting	-40°C	35°C	-40°C	45°C
Heater ON Setting (70% Fan Speed)	10°C	N/A	10°C	N/A
Heater OFF Setting	15°C	N/A	15°C	N/A
High Temp Alarm Setting	65°C	N/A	65°C	N/A
Low Temp Alarm Setting	0°C	N/A	0°C	N/A

3.2. Alarm Terminal Panel

All alarm wiring is connected to the 40-position alarm panel. Refer to the family practice LT-PM64412xxx for more information about the panel. The following table shows the macro alarm block wiring for this unit.

Alarm ID	Color	POS	Color	POS2
Door Intrusion	ORG	CC1	WHT/ORG	RET1
HVAC Failure	BLK	CC12	WHT	RET12
High Temp	GRN	CC13	WHT/GRN	RET13

4. SPECIFICATIONS

Physical	
Weight	Approx. 656 lbs. as shipped
Thermal	
HVAC System	(2) 48VDC, Vikinor VAK-5000-DC
Cooling Capacity	17000BTU per unit

Table 1 CUBE Specifications (see family document for full list)