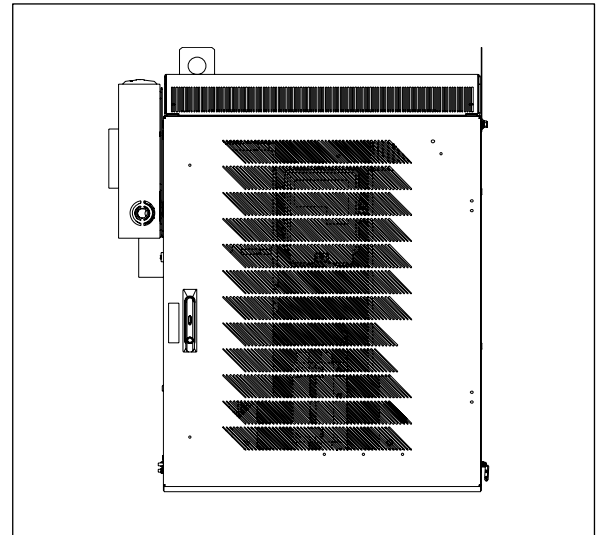


# Charles Universal Broadband Enclosure

## SHRD56-051 and SHRD56-601 Series

### General Description and Installation

<b>1. GENERAL INTRODUCTION .....</b>	<b>1</b>
1.1. Document Purpose .....	1
1.2. Product Purpose .....	1
1.3. Product Mounting and Location .....	1
<b>2. PRODUCT DESCRIPTION .....</b>	<b>2</b>
<b>3. INSTALLATION .....</b>	<b>11</b>
3.1. Inspecting the Product .....	11
3.2. Following and Using Safety Precautions .....	11
3.3. Obtaining Tools and Equipment .....	11
3.4. Preparing the Installation Site .....	11
3.5. Lifting the SHRD56 .....	12
3.6. Mounting the SHRD56 .....	12
3.7. SHRD56 Wiring and Equipment .....	14
3.8. Customer Equipment Mounting .....	21
<b>4. PERIODIC MAINTENANCE .....</b>	<b>27</b>
<b>5. TECHNICAL ASSISTANCE AND REPAIR SERVICE .....</b>	<b>27</b>
<b>6. WARRANTY &amp; CUSTOMER SERVICE .....</b>	<b>27</b>
<b>7. SPECIFICATIONS .....</b>	<b>28</b>



**Figure 1 Front View of the SHRD56**

## 1. GENERAL INTRODUCTION

### 1.1. Document Purpose

This document provides general information for the SHRD56-051xxxxx and SHRD56-601xxxxx of the Charles Industries' Universal Broadband Enclosure SHRD56 product line. Figure 1 shows a closed front view of an enclosure.

-NOTE-

*Hereafter, the Charles Universal Broadband Enclosure SHRD56-051xxxxx and SHRD56-601xxxxx will be referred by their part numbers or collectively as the "SHRD56".*

### 1.2. Product Purpose

The SHRD56 consists of a protective enclosure (shroud) that supports remote radio head (RRH) units and other customer supplied equipment.

### 1.3. Product Mounting and Location

This enclosure is suitable for outside plant-type (OSP) locations and those that may require NEC compliance. The outdoor SHRD56 products are to be mounted to a concrete pad or Charles CPAD. The installer connects the power, fiber and copper connections. Detailed mounting and installation information is covered in Section 3.

## 2. PRODUCT DESCRIPTION

SHRD56 has vents on the front, sides, and rear for ventilation. It is equipped with an 8-position AC load center and an AC surge suppressor. Most models have a meter socket (ring type or ringless, see Table 1). Models with part numbers ending in GB2 do not have a meter socket.

The SHRD56-051x8GB1 and GB2 models support five Ericsson 220x/440x, five Nokia Airscale Micro RRHs, or two Nokia Airscale Micro radios and one Nokia AWHHF radio. All radio configurations also support two Microlab BK-741W or two Commscope CBC1923 diplexers. It can also support one Delta 1kW or Eltek Chameleon 650W power supply. The Eltek power supply can be factory installed by ordering the 96-ELCHAM6501-A power supply kit.

The SHRD56-601x2GB1 and GB2 models support two Ericsson RUS32 or two Ericsson RUS11/12 RRHs, two Ericsson AC-02 or AC-08 power supplies, two Microlab or two Commscope diplexers and one fiber enclosure (Charles CFTT, AFL OptiNID, or Corning OptiSheath).

The SHRD56-601x3GB1, GB3, GB4, and GB5 models support two Nokia AHxxx dual band, two Nokia 4x30, two Nokia 4x45 or six Nokia Airscale Micro RRHs, two ABB, Nokia, or Delta power supplies, two Commscope diplexers, and one fiber enclosure (Charles CFTT, AFL OptiNID, or Corning OptiSheath). The GB5 model has a Raycap disconnect device in place of the AC load center.

The SHRD56-601xTGB1, TGB3, and TGB6 models support two radios total. Choose from Ericsson 8843, 4449, 4478, 4426, and 4415 RRH. It also supports either two Ericsson 6302 or four Ericsson AC-08 power supplies, two Commscope diplexers, and one Charles CFTT fiber box.

The SHRD56-601xWGB1 and GB5 models support two Samsung 320W dual band radios, one Samsung CBRS radio, two Delta or two ABB power supplies, four Commscope diplexers, and one Charles CFTT fiber box.

The SHRD56-601xYGB2 supports one Ericsson 4426 or 4419 radio, one Ericsson 4415 radio, one Ericsson 8863 radio, one Ericsson 6308 power supply, one Primex fiber box, and one Ericsson 6339 BBU.

Figure 2 shows the SHRD56 dimensions. Figures 3 through 9 show the SHRD56 components by model.

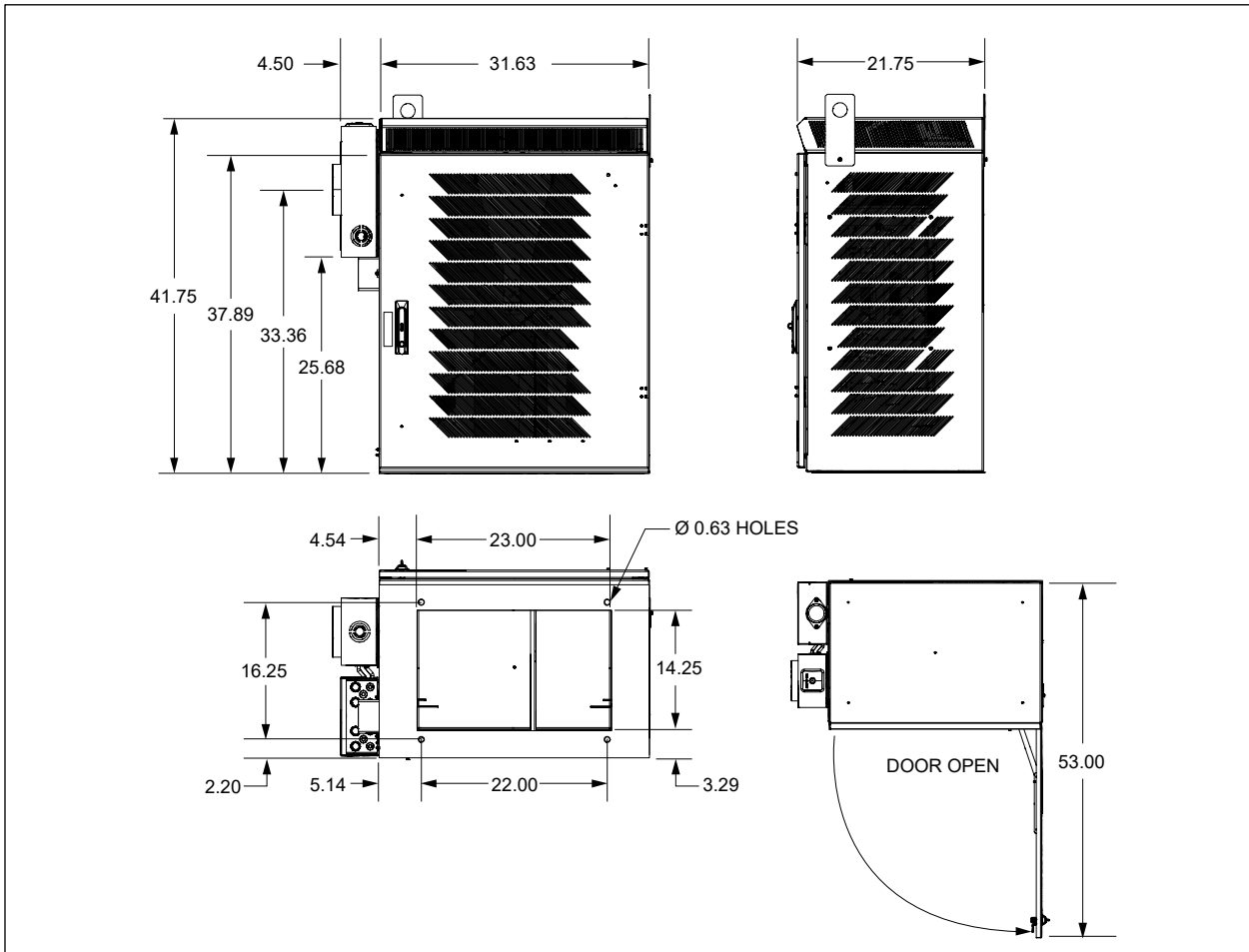
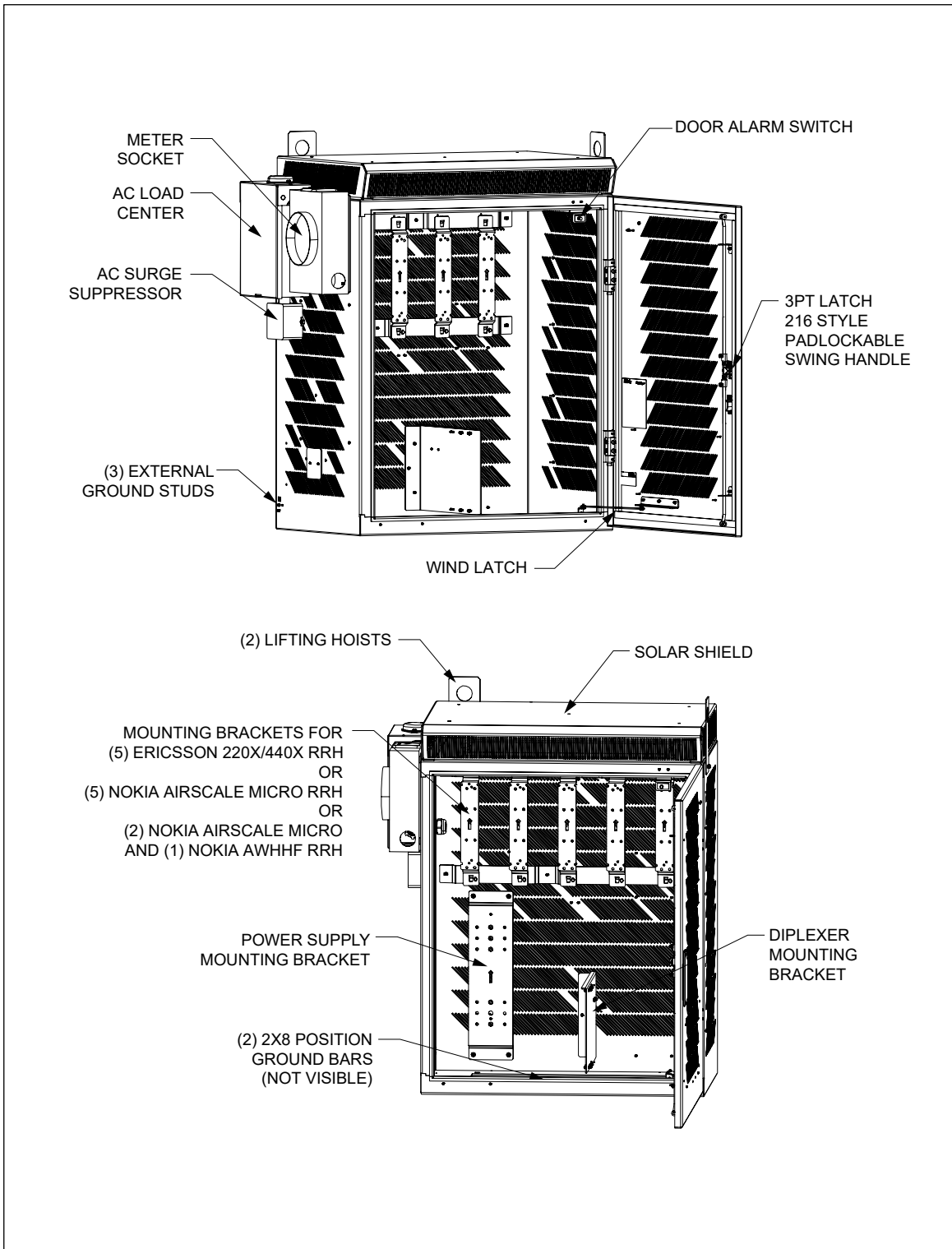
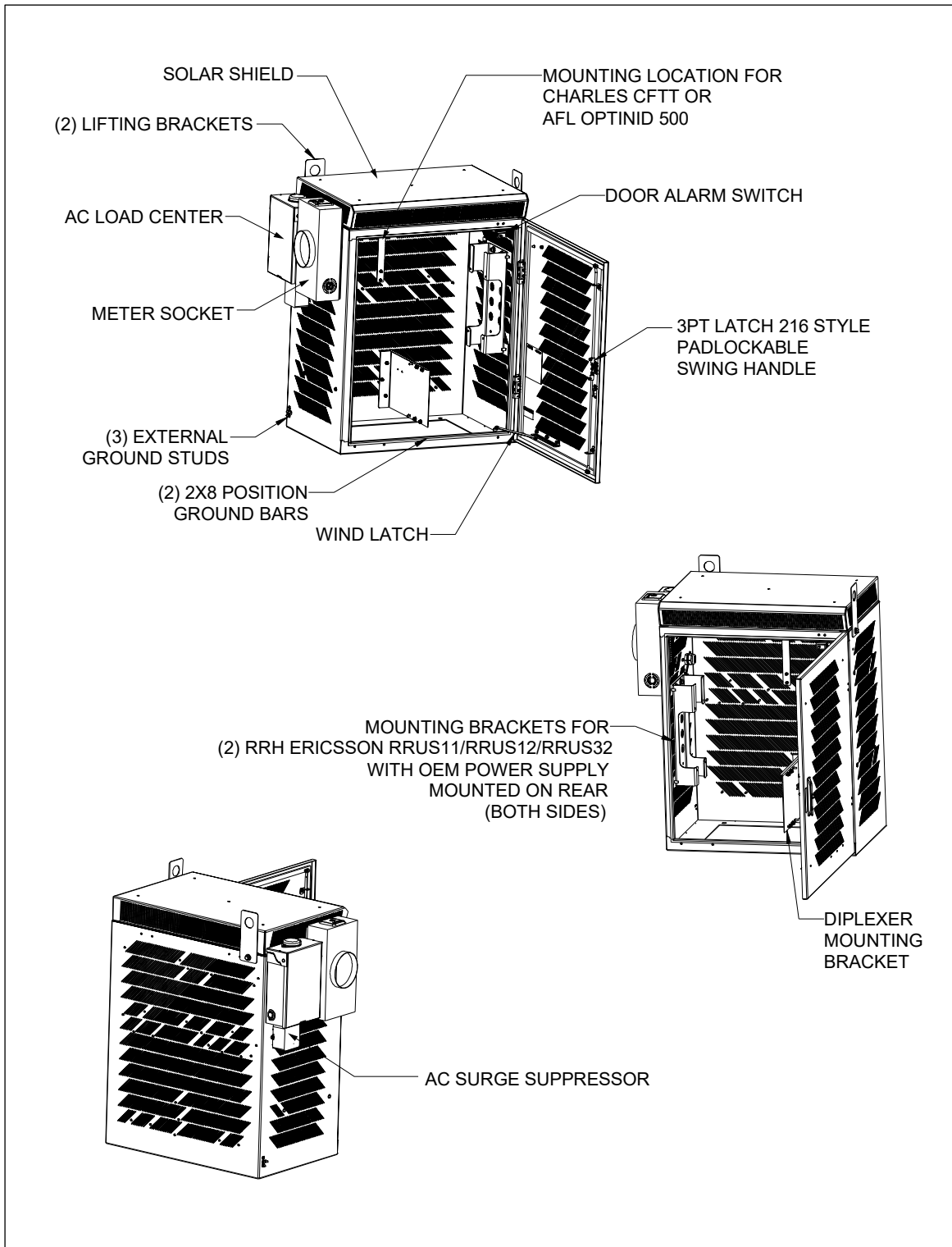


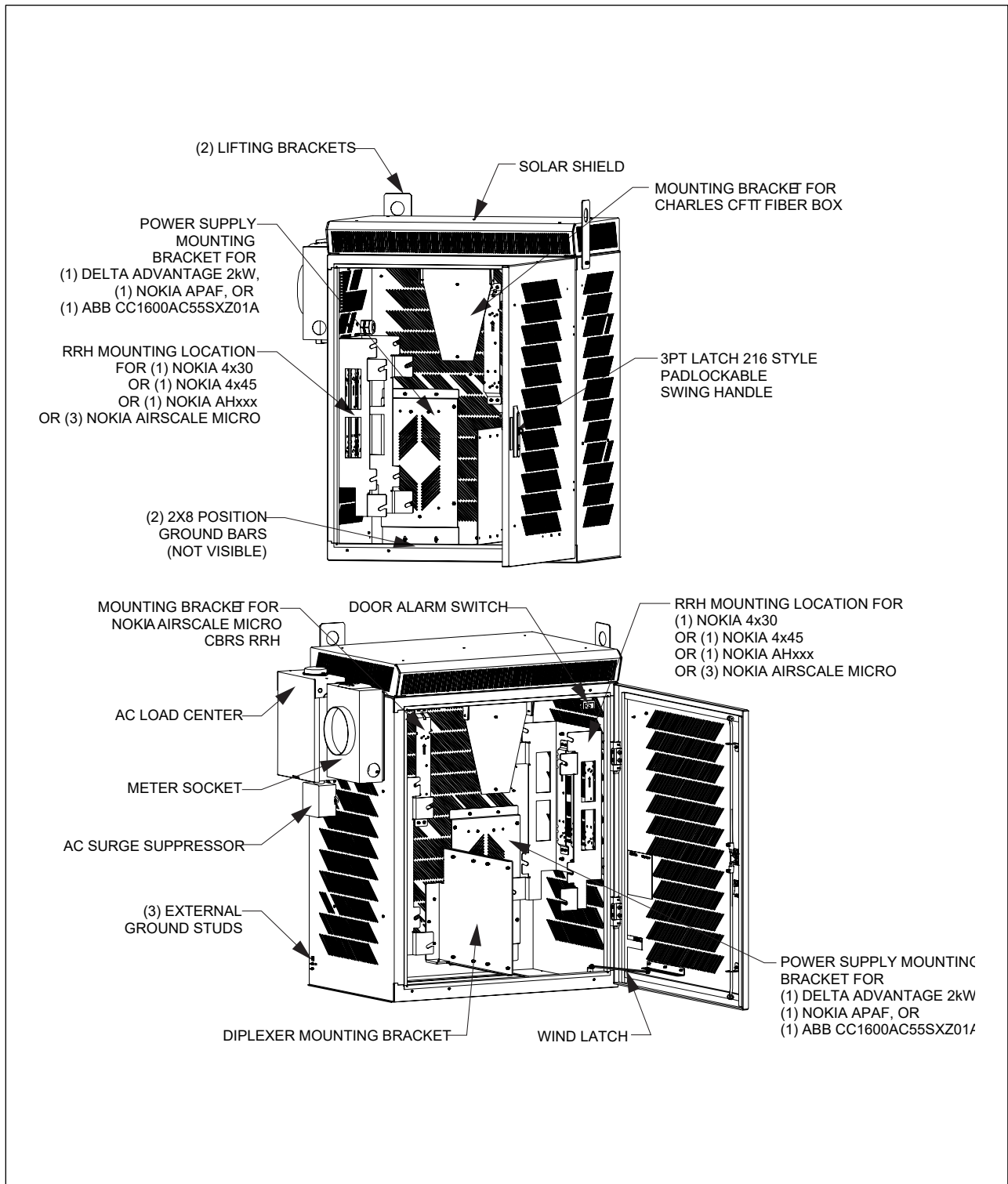
Figure 2 SHRD56 Dimensions (in inches)



**Figure 3 SHRD56-051x8GB1 Components**  
 (SHRD56-051x8GB2 is the same but without the meter socket)

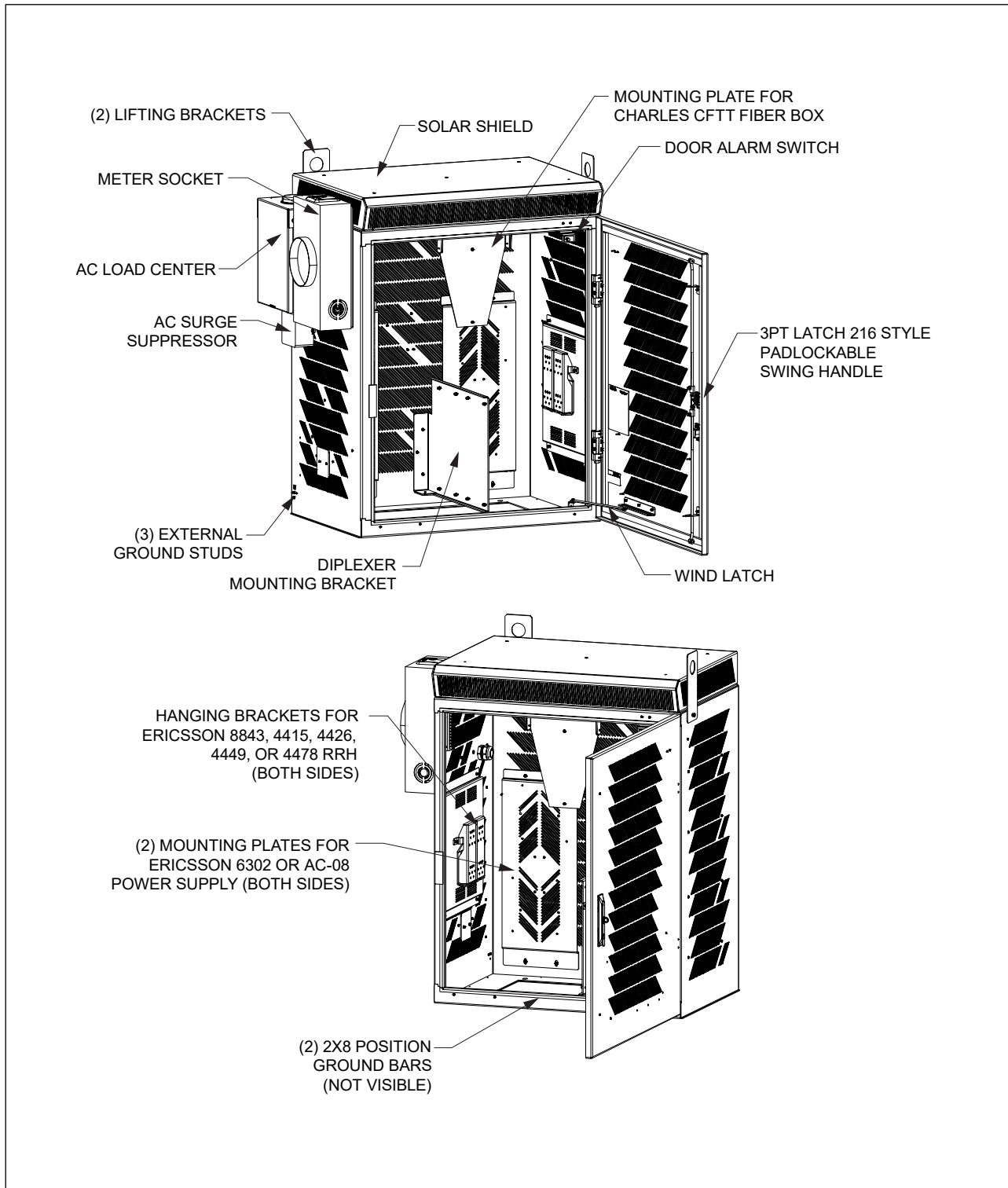


**Figure 4 SHRD56-601x2GB1 Components**  
(SHRD56-601x2GB2 is the same but without the meter socket)



**Figure 5** SHRD56-601x3GB1, SHRD56-601x3GB3, SHRD56-601x3GB4, and SHRD56-601x3GB5 Components  
 GB1 meter socket is ring type, GB3/GB5 is ringless, GB4 is ringless lever bypass type and larger.

**Note:** GB5 has a Raycap disconnect device in place of the AC load center.



**Figure 6 SHRD56-601xTGB1 and SHRD56-601xTGB3 Components**

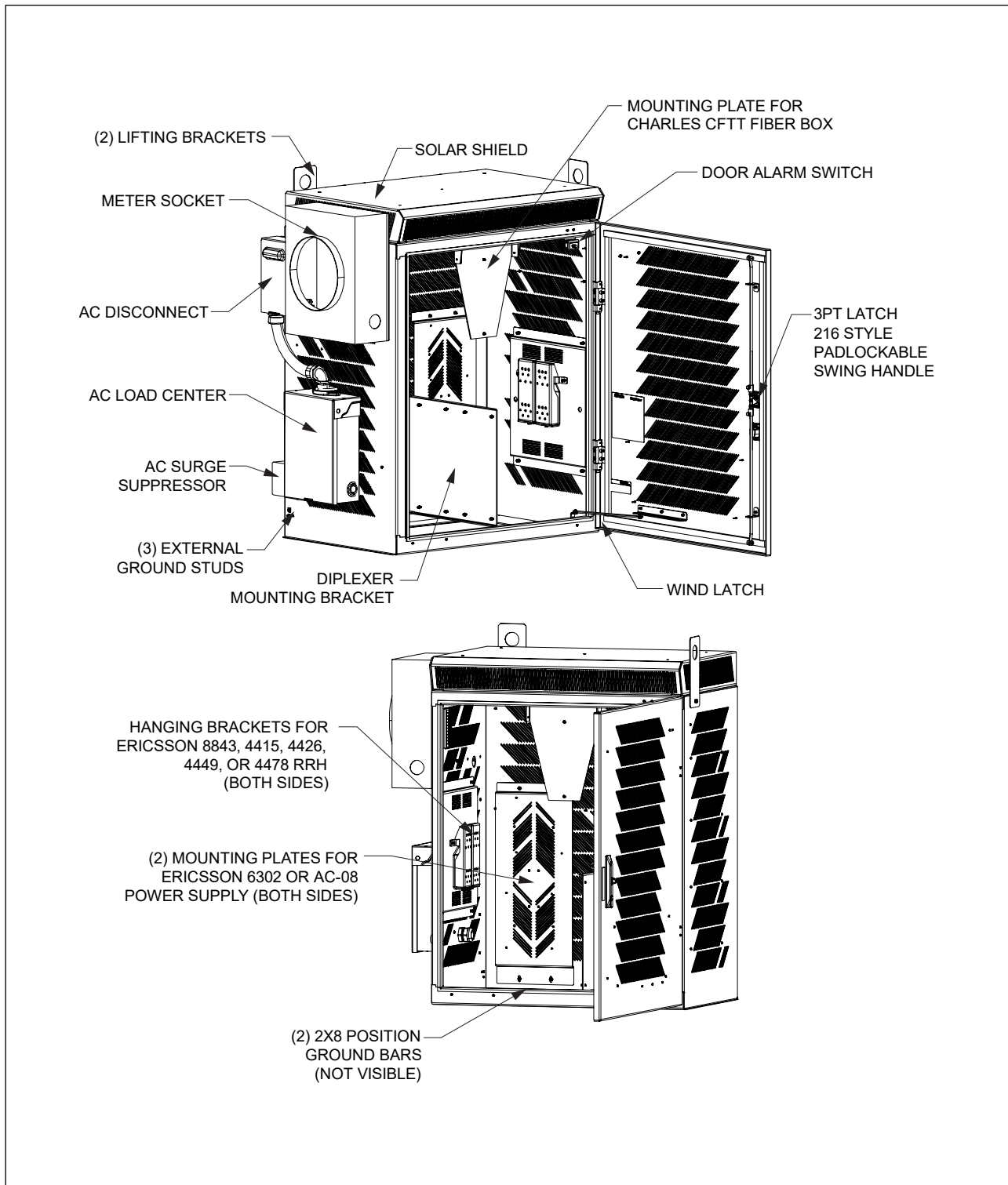
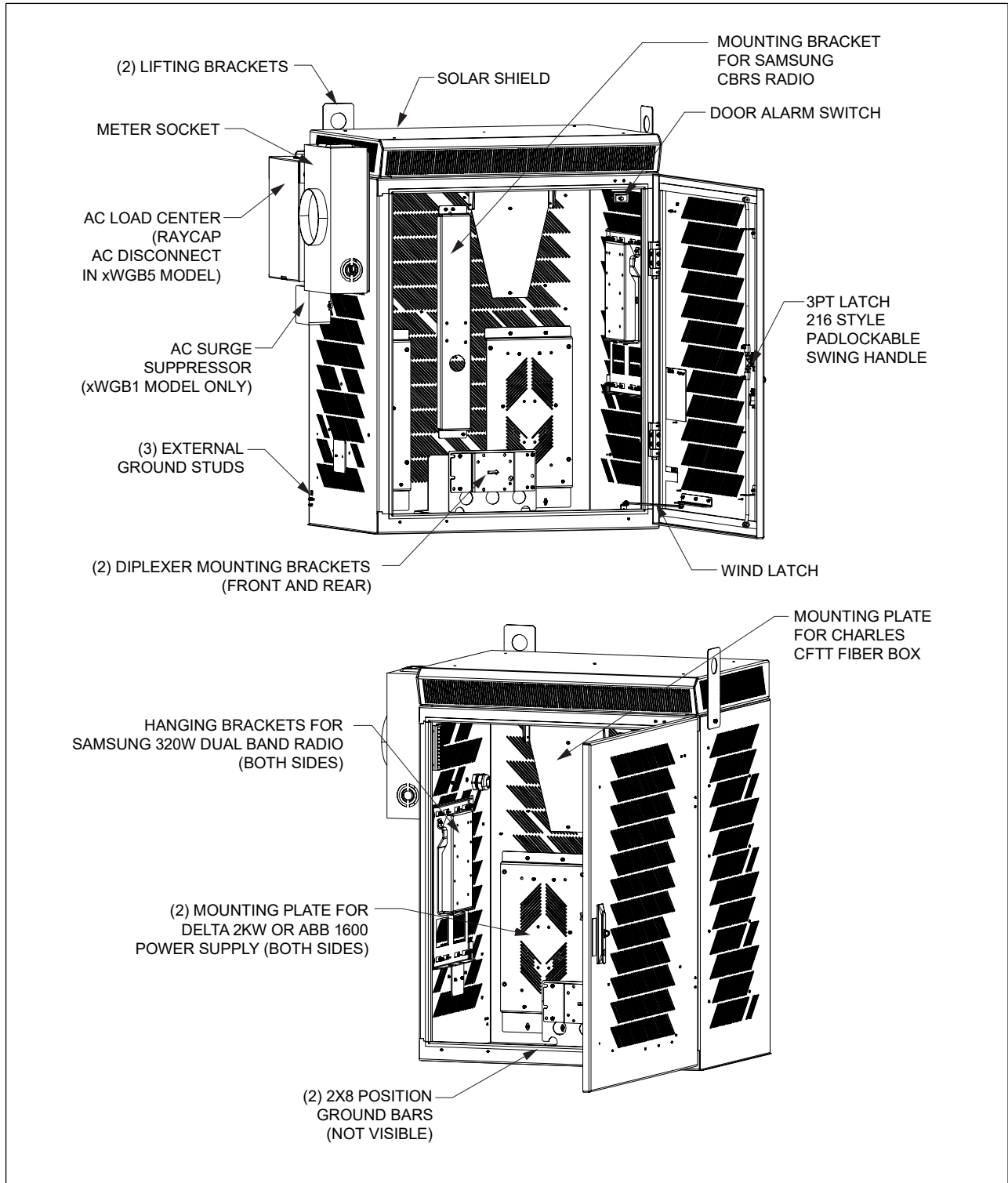


Figure 7 SHRD56-601xTGB6 Components





**Figure 8 SHRD56-601xWGB1 and SHRD56-601xWGB5 Components**  
All components are common to both models except where noted.

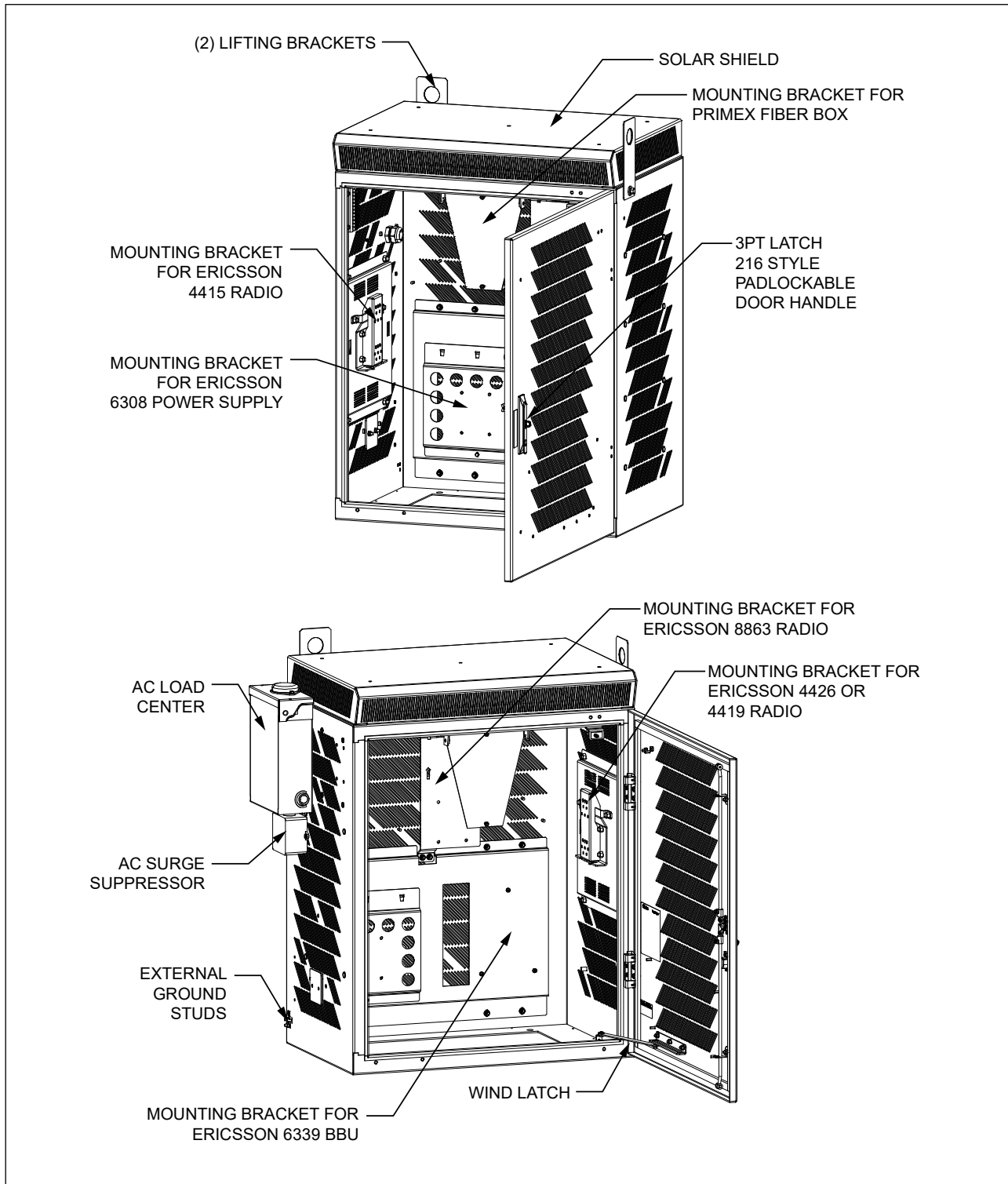


Figure 9 SHRD56-601xYGB2 Components

### 3. INSTALLATION

#### 3.1. Inspecting the Product

The SHRD56 is shipped mounted upright on a skid. Remove the bolts, unpack the unit, and dispose of the packaging material.

*-INSPECTION NOTE-*

*Visually inspect the unit for damages prior to installation. If the equipment was damaged in transit, immediately report the extent of the damage to the transportation company.*

#### 3.2. Following and Using Safety Precautions

Read the following site and safety tips, cautions, and warnings, then proceed with the paragraphs that follow.

- For installation, follow all National Electrical Codes (NEC) ANSI/NFPA 70, local, environmental, workplace, and company codes, safety procedures, and practices.
- Minimum spacing between the accessories and components and the housing for ITE equipment shall be maintained for safe operation of the equipment when installed in accordance with NEC ANSI/NFPA 70.
- Read all instructions, warnings and cautions on the equipment and in the documentation shipped with the product.
- Always connect ground connections first.
- Do not place this product on weak or unstable surfaces which may allow the product to fall, resulting in potentially serious damage(s) to persons or product.
- Only authorized trained personnel shall install the SHRD56.
- In windy conditions, be sure to engage the door latches to secure the door in a stationary position.

#### 3.3. Obtaining Tools and Equipment

Obtain the following recommended or needed items for installing the SHRD56.

- Sufficient length and quantities of fiber cable (or pigtails)
- Cable scoring, opening, and cutting tools for cable sheathing, shields, wrappings, strength members and buffer tubes
- Wire strippers
- Crimpers
- Cable, tube, wire, and fiber cleaning materials
- Protective and/or insulated work gloves
- Safety glasses
- Tape measure
- Marking utensil
- #6 ground wire or rod and earth ground materials
- Bond strap (optional, from cable bond clamp to bond post)
- Any exterior cable strain relief, per company practice
- Slotted, hex, and Phillips screwdrivers
- Torque wrench
- Assorted cable ties, clips, or fasteners (optional)
- Can wrench (216 type tool)
- Derrick for lifting
- Level

#### 3.4. Preparing the Installation Site

- Leave adequate horizontal and vertical space between multiple installations to allow for proper cable access, as well as enough room around the enclosure to open the door(s).
- The site must meet minimal personnel and equipment safety requirements.
- The distance from the cable entry point should be consistent with local installation practices.
- The pad must be able to support the weight of the SHRD56.
- Run all fiber and copper facilities to the site.

### 3.5. Lifting the SHRD56

See Table 1 for SHRD56 weight. Charles recommends the following procedure for lifting the SHRD56.

#### 3.5.1. Required Equipment

- One derrick (crane) capable of lifting the SHRD56
- Spreader bar
- Two lifting slings or chains with each having a 2,500 lbs. capacity
- Connecting links to attach slings to the SHRD56’s lifting brackets
- 75-ft. long tagline rope

Insert the lifting sling connecting links securely through each of the lifting brackets as shown in Figure 10.

#### 3.5.2. Warnings and Specific Safety Precautions

	<b>WARNING</b>	<b>Improper hoisting equipment and unsafe lifting procedures can result in serious injury or death</b>
--	----------------	--

Observe the following local safety procedures when performing the tasks in this section.

- Keep the SHRD56 away from any power lines.
- Keep bystanders away from the work operations at all times.
- Only trained operators shall operate the crane for lifting and setting the SHRD56.
- Do not suspend loads over people or equipment.
- All persons working with hoisting equipment shall wear standard safety gear according to local practices including safety helmets and steel-toed shoes.
- Do not operate the hoisting equipment until all stabilizer are extended and in firm contact with the ground or adequate support structure.
- Do not attempt to retract or extend the stabilizers while a load is suspended.

### 3.6. Mounting the SHRD56

The SHRD56 can be mounted on a new or existing concrete or composite pad. Charles Industries recommends the CPAD-S15EXCSH56 composite pad. A loose gasket is provided inside SHRD56 for placing the SHRD56 on a concrete pad. If the gasket becomes damaged during installation, order a replacement under part number 80-005172-A. The gasket is not needed if using a CPAD.

Charles offers an optional 18”H plinth kit (97-002375-A). See the documentation that ship with the kit for installation information.

#### 3.6.1. Torque Requirements

Torque all hardware as shown below (unless otherwise noted). These values apply to SAE Grade 1 & 2 Low Carbon Steel, ASTM A307 Low Carbon Steel, and Stainless Steel Grade 18-8.

Thread Size	In-lbs	Ft-lbs
4-40	4±10%	
6-32	8±10%	
8-32	16±10%	
10-32	26±10%	
12-24	50±10%	
1/4-20/M6	60±5%	5±5%
5/16-18	125±5%	10.4±5%
3/8-16	180±5%	15.0±5%
1/2-13	500±2%	41.7±2%
5/8-11	1000±1%	83.3±1%

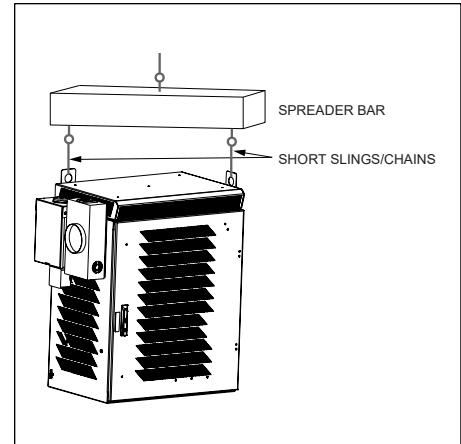
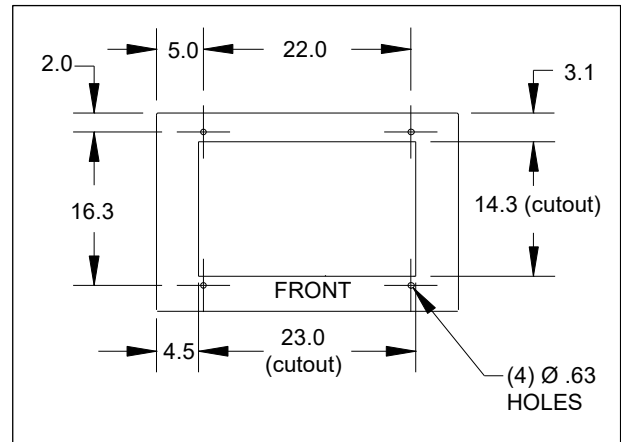


Figure 10 Lifting the SHRD56

**3.6.2. Constructing a New Pad**

- Use only concrete for new pad construction. Do not use substitute materials since they lack the rigidity for SHRD56 placement.
- Observe local building practices for pad construction. Charles recommends that the pad should extend a minimum of 8” beyond the SHRD56 base on all sides.
- Use a minimum of 6” of sand or gravel as a base for the pad for leveling purposes.
- Figure 11 shows the required conduit openings and mounting hole dimensions for entering/mounting the bottom of the SHRD56. Use these dimensions when designing the pad.

	<b>WARNING</b>	<p><b>When pad mounting, the compression strength of the pad must be at least 4000 psi as determined by ASTM C39 test of compression strength of concrete cylinders.</b></p> <p><b>The slump of the concrete shall be 2” to 4” as determined by ASTM C143 test method.</b></p>
--	----------------	--



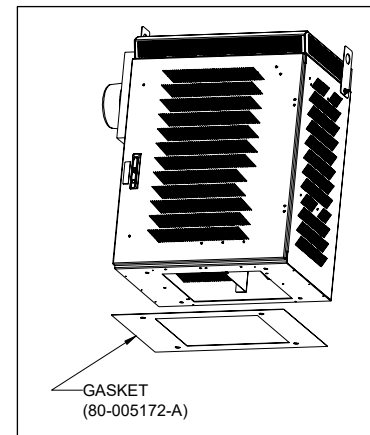
**Figure 11 Mounting Hole Dimensions (in inches)**

**3.6.3. Mounting the SHRD56 on a Pad**

Four customer supplied corrosion resistant 1/2”-13 hex head bolts with anchors are required for mounting the SHRD56 to the concrete pad. Use the following steps to mount the SHRD56 to a pad.

The following steps are used for mounting the SHRD56 on a concrete pad.

1. Layout, drill, and set the 1/2” anchors per manufacturer’s recommendations. The embedment depth is not to exceed 3.5”. Use the gasket as a mounting hole location template. Remove the anchor bolts for later reuse.
2. Clean any debris from the concrete pad.
3. Install the gasket by positioning it on the pad so that it is underneath the bottom of the SHRD56 when the cabinet is installed. Line up the gasket so that the cutouts are in proper position around the conduit opening and over the anchor bolts as shown in Figure 12.
4. Open the SHRD56 door to allow access to mounting holes.
5. Ensure that the SHRD56 is parallel to the pad surface as it is placed onto the pad and that it aligns with the holes in the pad and the gasket. Dress the cable/conduit so that it aligns with the SHRD56 openings as it is lowered onto the pad.
6. Place the SHRD56 on the pad. Loosen the slings so that all the weight is on the pad. Check that the SHRD56 is properly aligned.
7. Secure the SHRD56 to the pad using 1/2” hardware. Tighten all bolts securely.
8. Once the SHRD56 is secured, remove the slings and tagline. Close the SHRD56 door.



**Figure 12 Gasket Installation**

**3.6.4. Mounting the SHRD56 on a CPAD**

First, follow the instructions that ship with the CPAD to ensure that the CPAD is securely installed in the ground. Then proceed to mount the SHRD56 on the CPAD. Four customer supplied, corrosion resistant, 1/2”-13, 2” long fully threaded hex head bolts are required for mounting the SHRD56 to the CPAD. Use the following steps to mount the SHRD56 to a CPAD.

1. Clean any debris from the concrete CPAD.
2. Open the SHRD56 door to allow access to mounting holes.
3. Ensure that the SHRD56 is parallel to the CPAD surface as it is placed onto the CPAD and that it aligns with the holes in the CPAD. Dress the cable/conduit so that it aligns with the SHRD56 openings as it is lowered onto the CPAD.
4. Place the SHRD56 on the CPAD. Loosen the slings so that all the weight is on the CPAD. Check that the SHRD56 is properly aligned.
5. Secure the SHRD56 to the CPAD using 1/2” hardware. Tighten all bolts securely.
6. Once the SHRD56 is secured, remove the slings and tagline. Close the SHRD56 door.

### 3.7. SHRD56 Wiring and Equipment

After the SHRD56 is properly mounted in the desired location, apply No-Ox where bus bar and other 2-hole lug connections will be made. Install ground and power connections. Always ground the equipment first, before making any other connections.

**WARNING** Perform all bonding and grounding connections prior to any electrical and communications connections.

Basic electrical diagrams are shown in Figures 13 through 22.

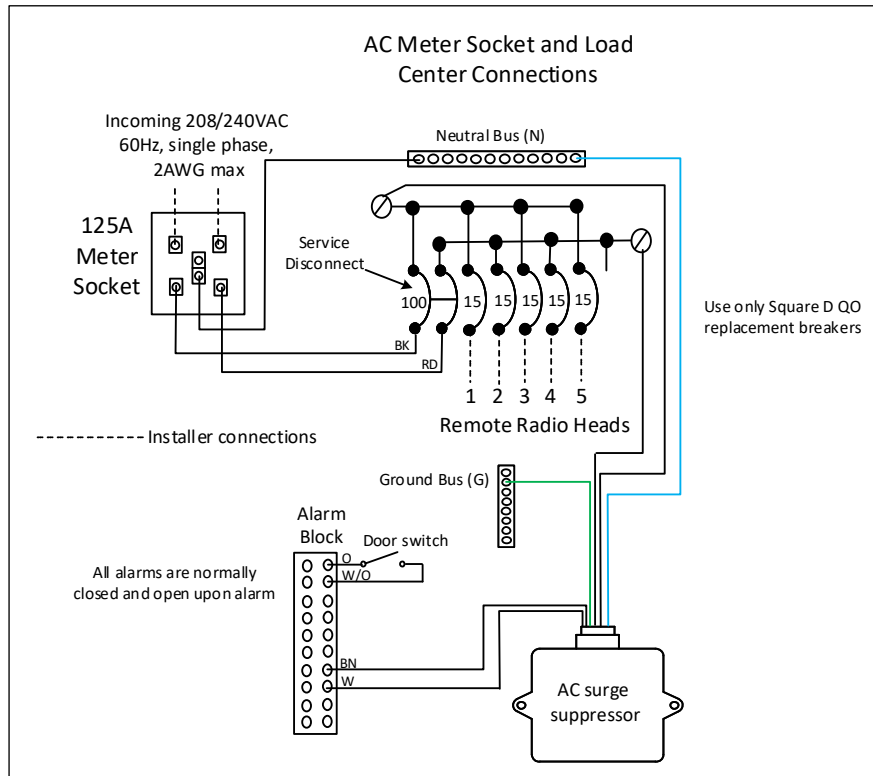
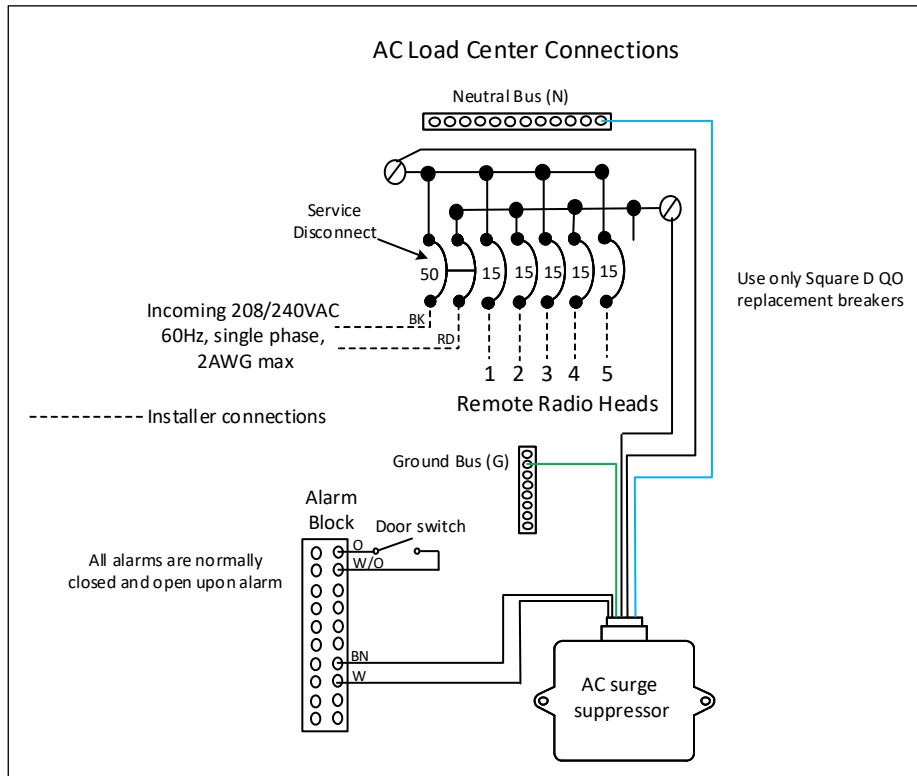
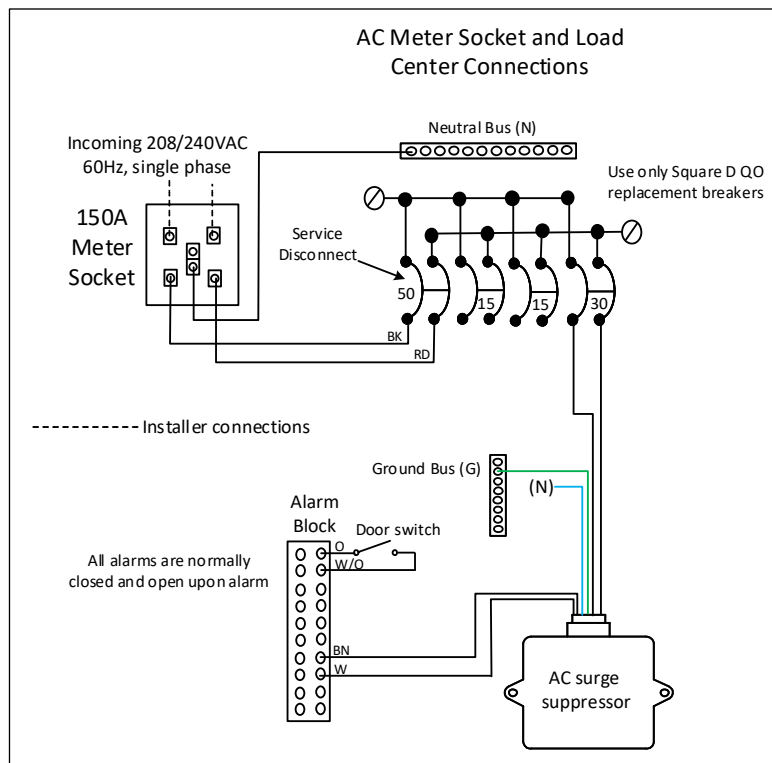


Figure 13 SHRD56-051x8GB1 Electrical Diagram



**Figure 14** SHRD56-051x8GB2 Electrical Diagram



**Figure 15** SHRD56-601x2GB1, SHRD56-601x3GB1, and SHRD56-601xWGB1 Electrical Diagram

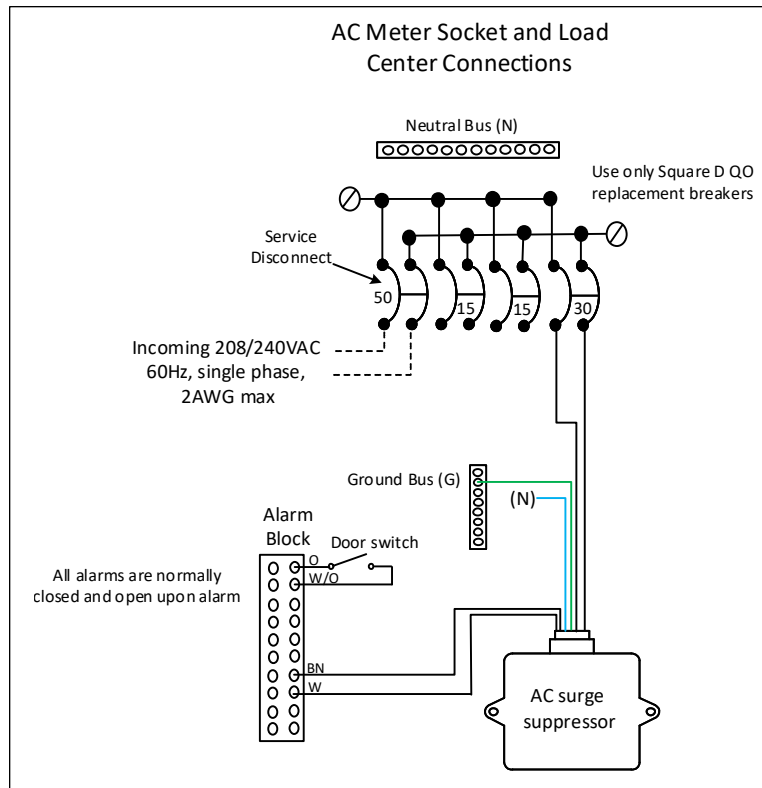


Figure 16 SHRD56-601x2GB2 Electrical Diagram

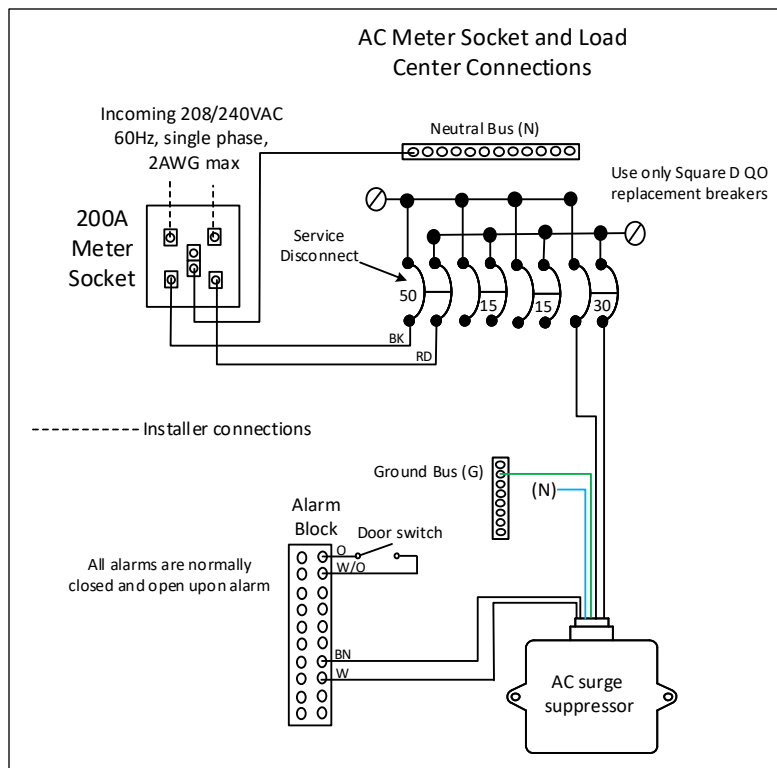


Figure 17 SHRD56-601x3GB3 Electrical Diagram



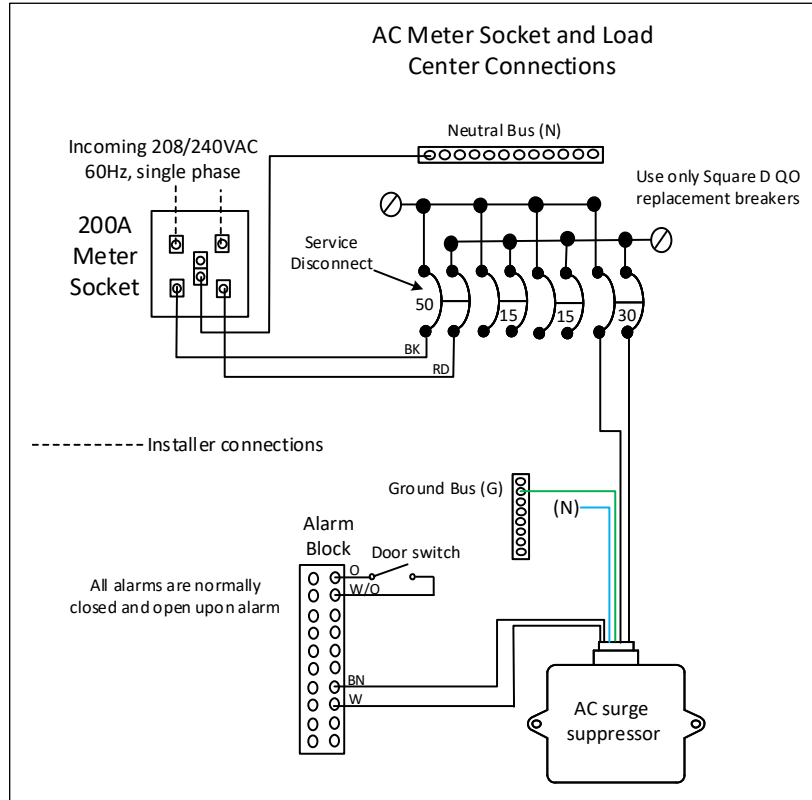


Figure 18 SHRD56-601x3GB4 Electrical Diagram

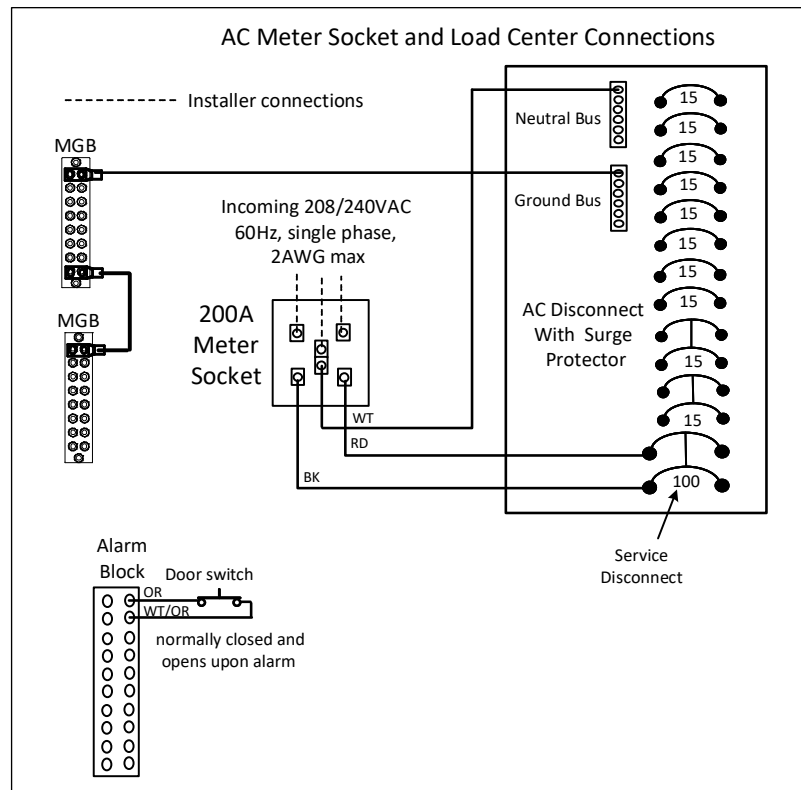


Figure 19 SHRD56-601x3GB5 and SHRD56-601xWGB5 Electrical Diagram

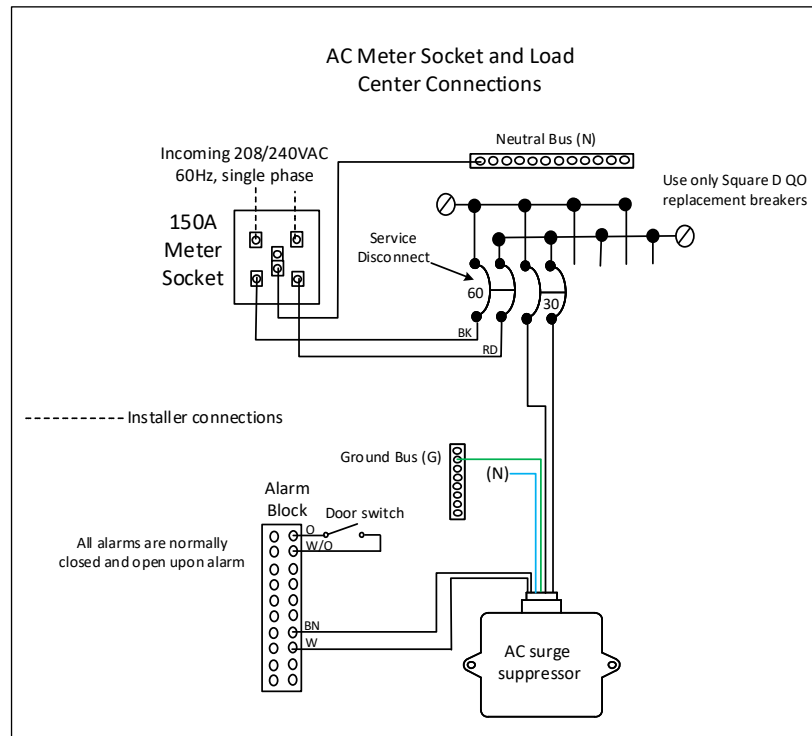


Figure 20 SHRD56-601xTGB1 and SHRD56-601xTGB3 Electrical Diagram

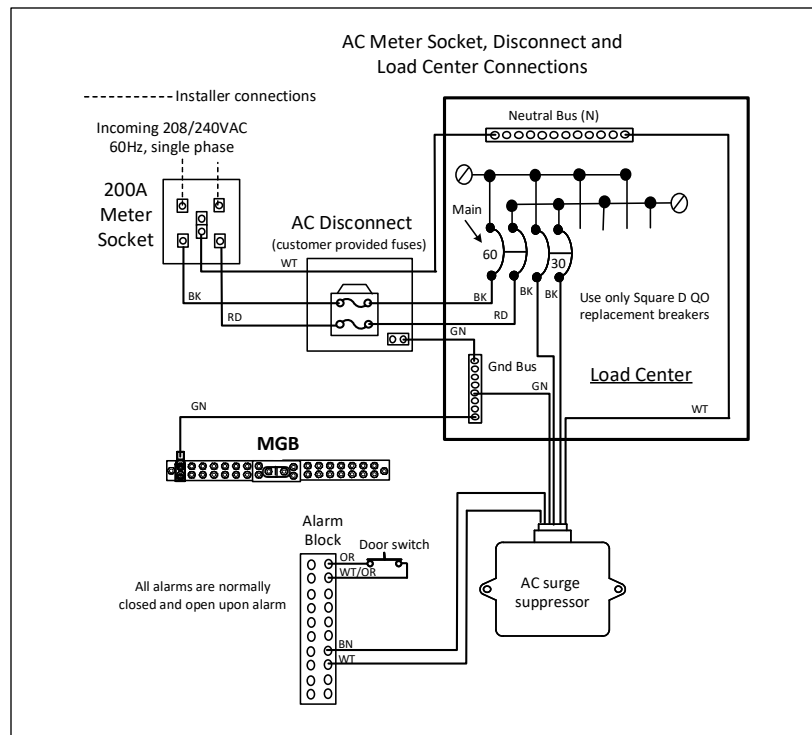


Figure 21 SHRD56-601xTGB6 Electrical Diagram

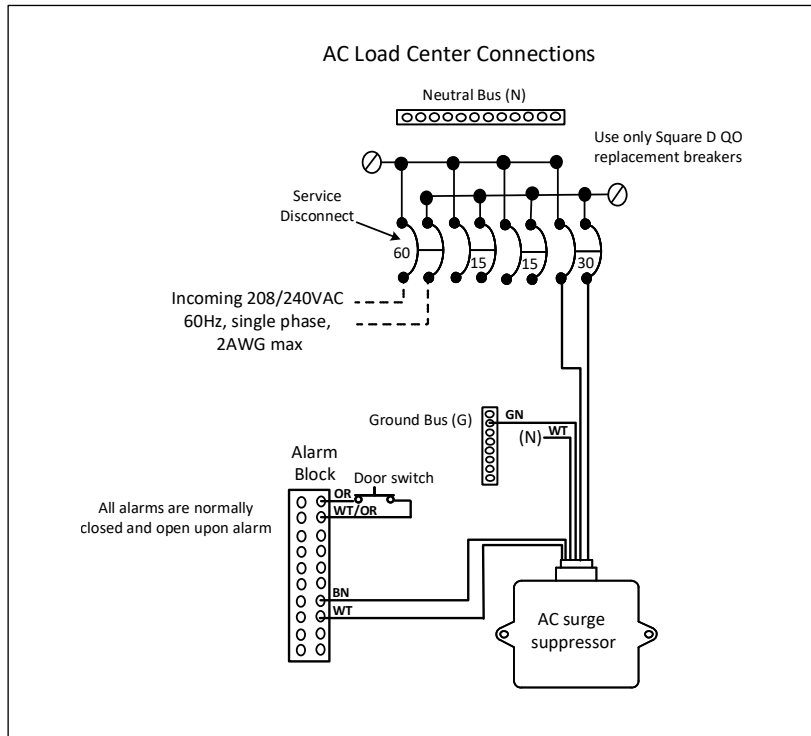


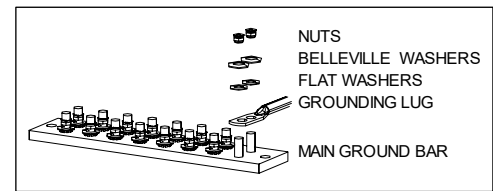
Figure 22 SHRD56-601xYGB2 Electrical Diagram

**3.7.1. Ground Connection**

Use the two 2x8 position ground bars provided in the SHRD56 for all grounding of internal equipment. Stack hardware as shown in Figure 23. Three threaded ground studs are available on the left side of the cabinet connecting a site ground wire.

**3.7.2. Optional Fan Kit**

The SHRD56-601xTGB1 can be ordered with the optional 96-SH5660FNKIT1 fan kit. This kit includes two direct air cooling fans and an AC/DC power supply, and it is installed at the factory. The fans are connected to a control thermostat and -48VDC power with a 2A to 10A breaker (Figure 24). The control thermostat is set at 110°F (±5°F). The thermostat turns the cooling fans on at the set point and turns them off when the temperature drops to 95°C (±5°F).



**Figure 23**  
**Ground Bar Hardware Stack**

-NOTE-  
*Thermostat set point cannot be modified.*

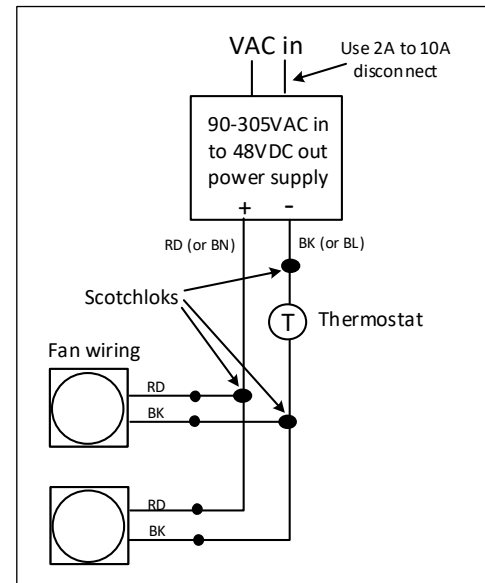
**3.7.3. AC Voltage Connections**

The incoming AC voltage is a single phase 208/240VAC at 60Hz. In units equipped with a meter socket, the installer connects the voltage to the meter socket, which is connected to the service disconnect breaker in the AC load center. For units not equipped with a meter socket, the installer connects the incoming voltage directly to the service disconnect breaker. Use wire that is sized per National Electrical Code NFPA70 table 310.16.

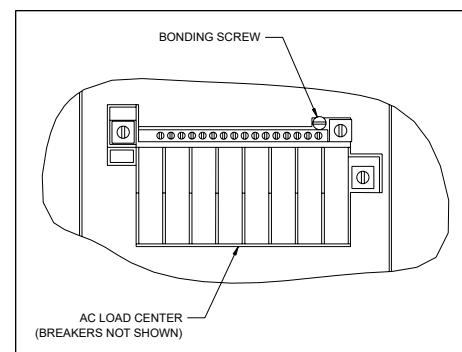
The AC load center is configured as a main panel with the neutral and ground busses connected together via the bonding screw shown in Figure 25.

**3.7.4. Alarm Block Connections**

The 10-position, labeled alarm block is used for monitoring alarm conditions in the cabinet. The alarm connections are normally closed and will open upon a failure. Refer to the electrical diagram for information about the alarm connections.



**Figure 24** Fan Kit Wiring



**Figure 25** AC Bonding Screw

### 3.8. Customer Equipment Mounting

The RRH mounting brackets are shipped attached to the rear of the SHRD56-051 or on the rear and sides of the SHRD56-601. Figures 28 through 35 show the SHRD56 with customer supplied equipment installed.

#### 3.8.1. SHRD56-051x8GB1

1. Remove the mounting bracket from the SHRD56. Save the hardware.
2. Install the bracket on the radio using customer supplied hardware.
3. Hang the radio/bracket assembly onto the horizontal bar on the rear of the SHRD56 and secure with the hardware removed previously.

#### 3.8.2. SHRD56-601x2GB1

Slide the radio into the bracket. Secure the radio in place using customer supplied hardware through the four holes on the front of the bracket.

#### 3.8.3. SHRD56-601x3GB1, SHRD56-601x3GB3, and SHRD56-601x3GB5

Each of the two large RRH mounting locations on the side panels can support one Nokia AHxxx dual band, one Nokia 4x30, or one Nokia 4x45 radio. Position the radio mounting bolts into the slots on the radio mounting brackets, and tighten the bolts to secure the radios in place.

Within each of the large RRH brackets are three smaller brackets for the Nokia Airscale Micro RRHs. Remove the bracket, attach it to the RRH using customer supplied hardware, and mount the radio/bracket assembly back into position, observing the “UP” arrow stamped on the bracket.

The bracket on the rear panel supports one Nokia Airscale Micro CBRS RRH. Remove this bracket, attach to the RRH using customer supplied hardware, and mount this assembly into its original position, observing the “UP” arrow stamped on the bracket.

With any RRH configuration, the SHRD56-601x3GB1 can support two ABB, two Nokia, or two Delta power supplies. Remove these brackets, attach to the power supplies using customer supplied hardware, and mount the assemblies into their original positions.

Mount the CFTT onto the panel at the center front of the SHRD56. To improve access to the radios, the CFTT panel can slide left or right.

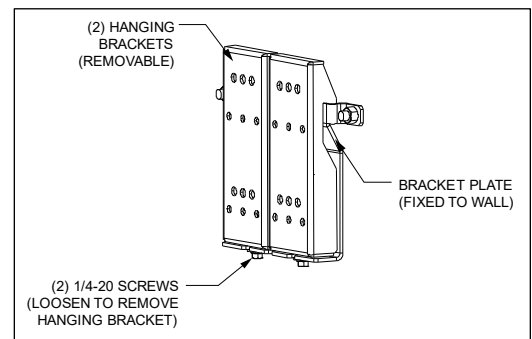
#### 3.8.4. SHRD56-601xTGB1

The radios mount on hanging brackets on the side walls of the SHRD56 (Figure 26).

1. Loosen the 1/4-20 screw on the bottom of the hanging bracket.
2. Lift the hanging bracket off of the bracket plate (plate stays on SHRD56 wall).
3. Attach the hanging bracket to the equipment with customer supplied hardware.
4. Return the hanging bracket to its position in the plate and tighten the screw.

To mount power supplies:

1. Remove the power supply mounting plate.
2. Mount either one Ericsson 6302 or two Ericsson AC-08 to the mounting plate using customer supplied hardware.
3. Mount this assembly to the SHRD56.
4. Repeat for the second mounting plate.



**Figure 26 Mounting Brackets**

**3.8.5. SHRD56-601xWGBx**

Mount the CBRS radio on the bracket on the rear panel.

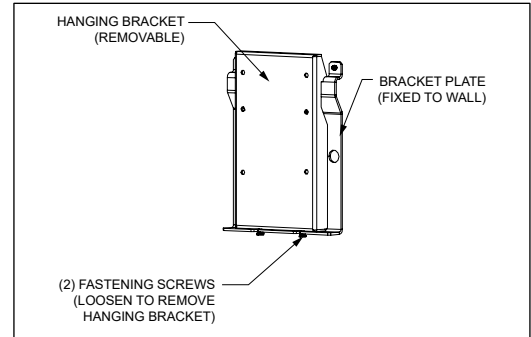
1. Remove the mounting bracket from the SHRD56. Save the hardware.
2. Install the bracket on the radio using customer supplied hardware.
3. Hang the radio/bracket assembly rear panel of the SHRD56 and secure with the hardware removed previously.

The dual band radios mount on hanging brackets on the side walls of the SHRD56 (Figure 27).

1. Loosen the 1/4-20 screws on the bottom of the hanging bracket.
2. Lift the hanging bracket off of the bracket plate (plate stays on SHRD56 wall).
3. Attach the hanging bracket to the equipment with customer supplied hardware.
4. Return the hanging bracket to its position in the plate and tighten the screws.

To mount power supplies:

1. Remove the power supply mounting plate.
2. Mount either one Delta 2kW or one ABB power supply to the mounting plate using customer supplied hardware.
3. Mount this assembly to the SHRD56.
4. Repeat for the second mounting plate.



**Figure 27 Mounting Brackets**

**3.8.6. SHRD56-601xYGB2**

Mount the Ericsson 8863 radio first, as this is mounted on the upper half of the rear panel.

1. Remove the mounting bracket from the SHRD56. Save the hardware.
2. Install the bracket on the radio using customer supplied hardware.
3. Hang the radio/bracket assembly rear panel of the SHRD56 and secure with the hardware removed previously.

Mount the Ericsson 6308 power supply and the Ericsson BBU on the mounting panel in the lower half of the SHRD56 rear.

1. Remove the mounting panel by removing the eight Keps nuts and washers. Save the hardware.
2. For the 6308 power supply, remove the bracket by removing the screw at the bottom and lifting the bracket off of the panel. Attach the bracket to the power supply, then hang the bracket hooks back onto the holes on the panel. Replace the screw at the bottom of the bracket.
3. Attach the BBU to the mounting panel directly using three customer supplied screws.
4. Replace the mounting panel onto the SHRD56 rear wall.

The Ericsson 4426/4419 and 4415 radios mount on hanging brackets on the side panels of the SHRD56. These hanging brackets are described in previous sections.

Mount the Primex fiber box on the panel at the top-center of the SHRD56 using two customer supplied nuts.

**3.8.7. Optional 96-000713-0 Radio Mounting Kit**

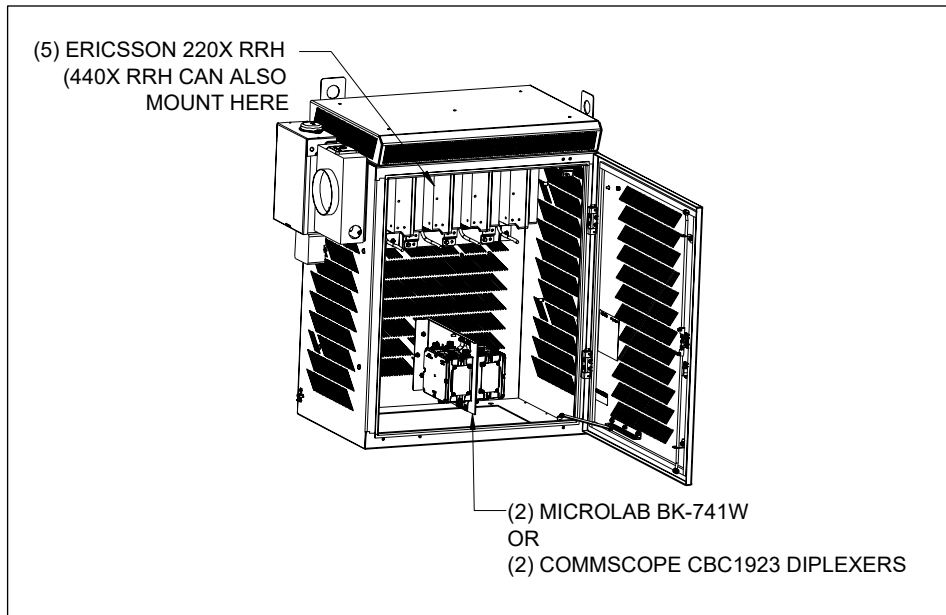
**SHRD56-601x3GB1, GB2, GB3, and GB4 models only.**

If the 96-000713-0 mounting kit was ordered, then the SHRD56 is shipped with an additional bracket on the left side that supports one Nokia B41 Mini Macro radio. To install this radio, remove this bracket, attach to the RRH using customer supplied hardware, and mount this assembly into its original position.

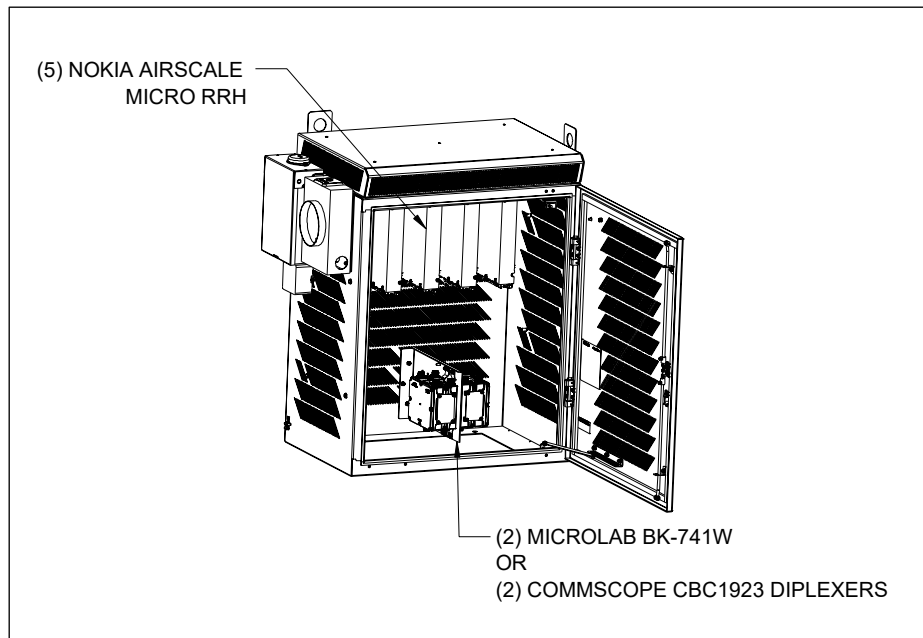
**3.8.8. Optional 96-ELCHAM6501-A Power Supply Kit**

**SHRD56-051x8GB1 and GB2 models only.**

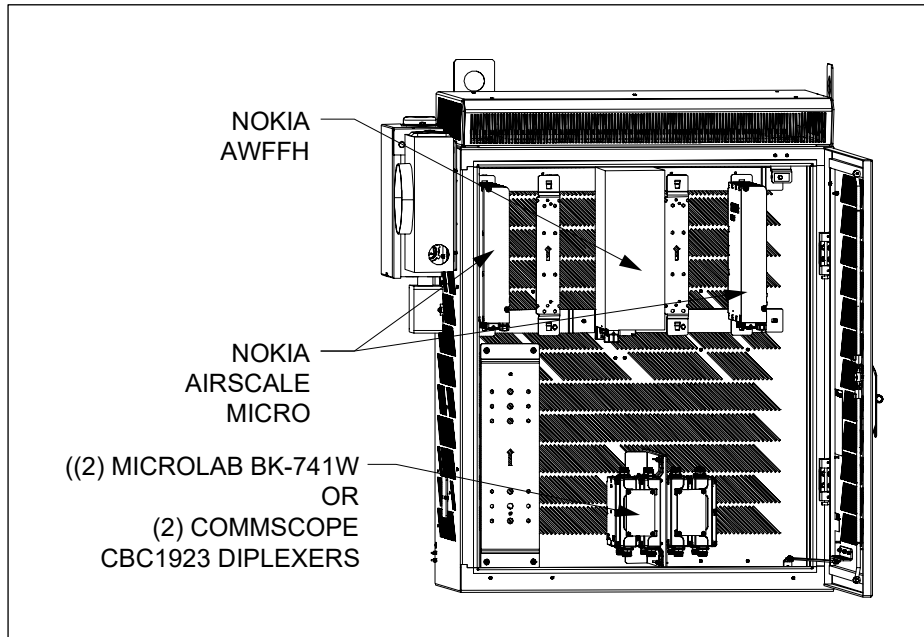
If the 96-ELCHAM6501-A mounting kit was ordered, then the SHRD56 is shipped one Eltek power supply installed.



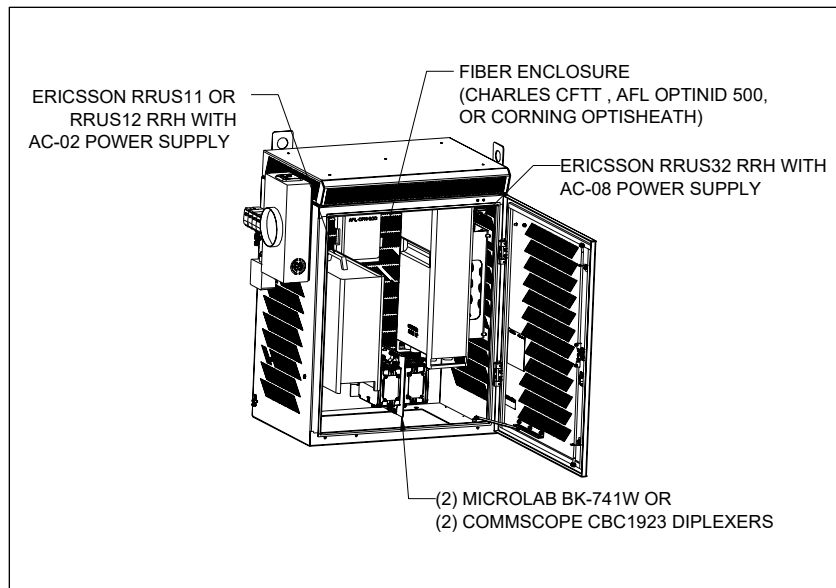
**Figure 28 SHRD56-051x8GB1 with Ericsson Equipment  
(SHRD56-051x8GB2 is the same but without the meter socket)**



**Figure 29 SHRD56-051x8GB1 with Five Nokia Airscale  
(SHRD56-051x8GB2 is the same but without the meter socket)**

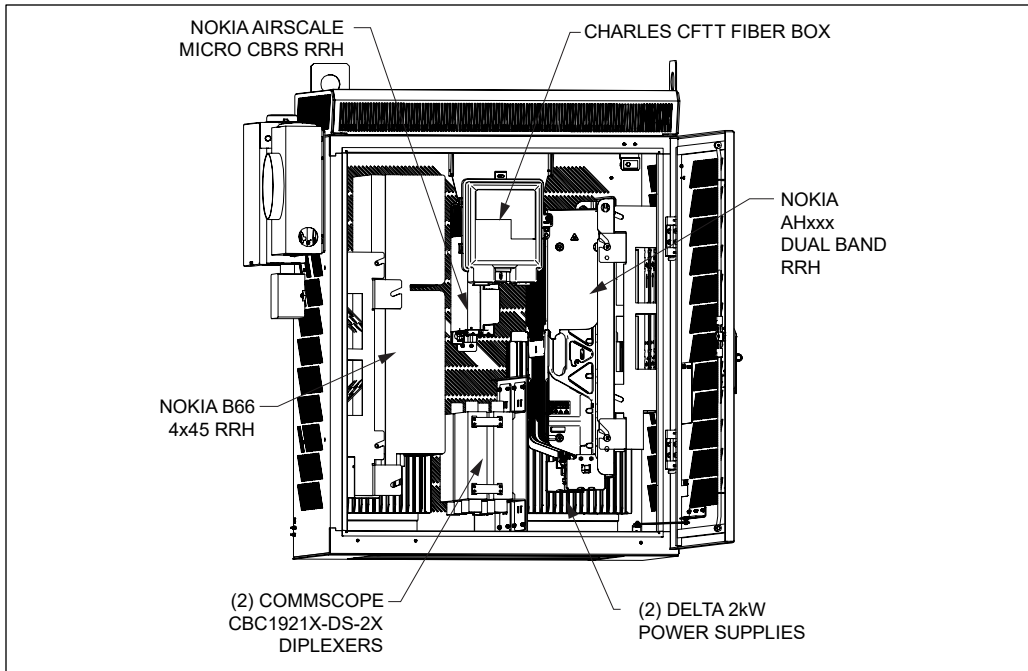


**Figure 30 SHRD56-051x8GB1 with Two Nokia Airscale and One Nokia AWHFH (SHRD56-051x8GB2 is the same but without the meter socket)**

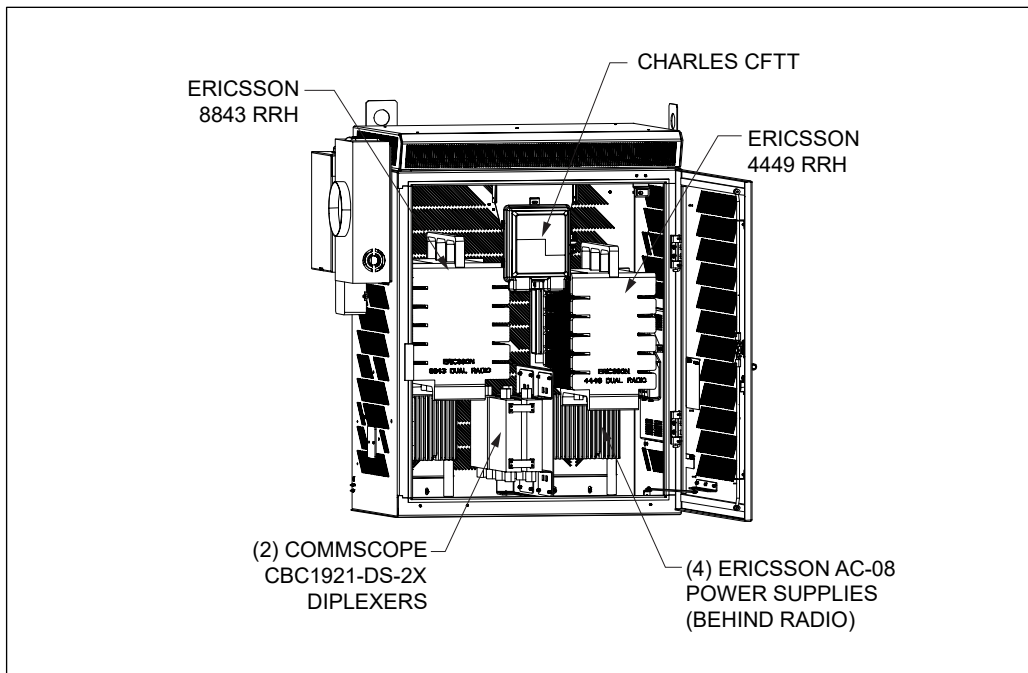


**Figure 31 SHRD56-601x2GB1 with Equipment (SHRD56-601x2GB2 is the same but without the meter socket) (Any of the RRHs shown can be installed in either location in the SHRD56)**

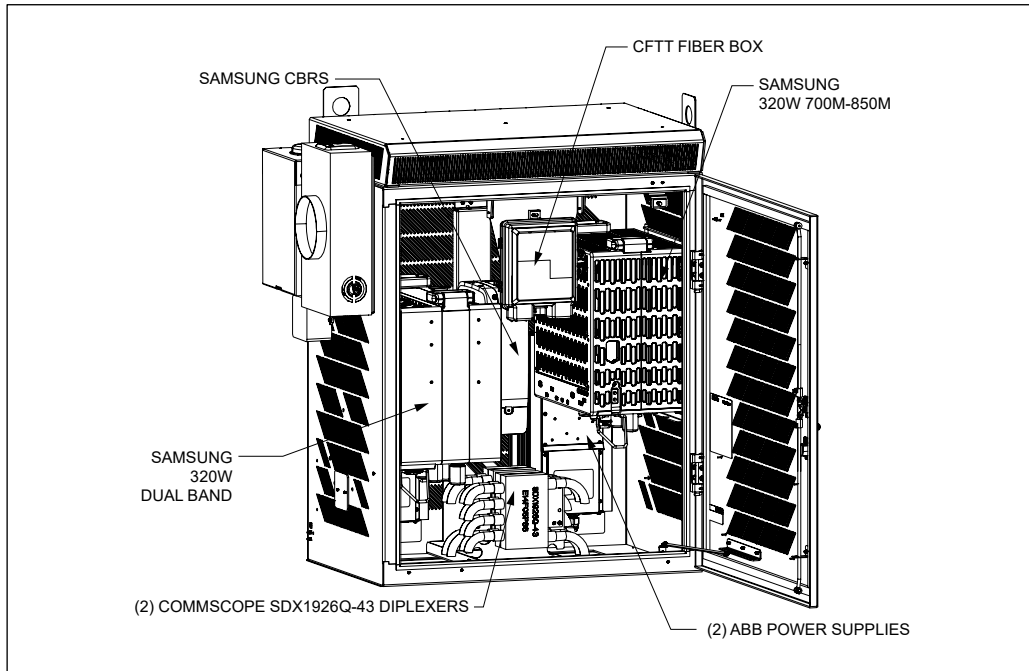




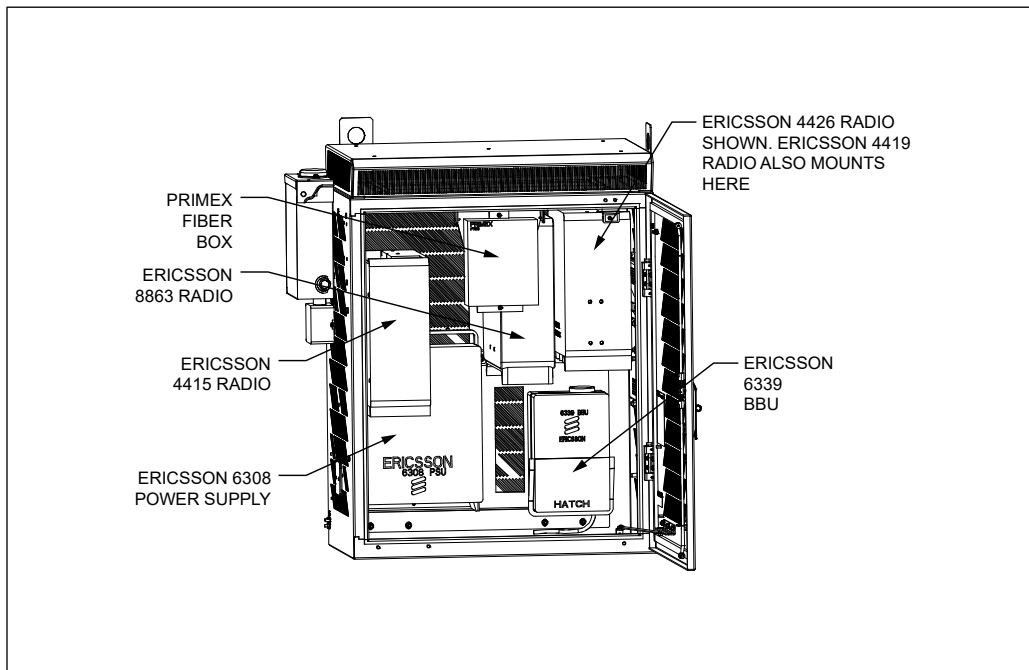
**Figure 32** SHRD56-601x3GB1, SHRD56-601x3GB3, SHRD56-601x3GB4, and SHRD56-601x3GB5 with Equipment  
(Configuration Example; other RRHs and power supplies can be used; Meter socket in GB4 model is larger.)



**Figure 33** SHRD56-601xTGB1, SHRD56-601xTGB3, SHRD56-601xTGB6 with Equipment  
(Configuration Example; other RRHs and power supplies can be used.)



**Figure 34 SHRD56-601xWGB1 and SHRD56-601xWGB5 with Equipment (Configuration Example; other RRHs and power supplies can be used.)**



**Figure 35 SHRD56-601xYGB2 with Equipment**

#### **4. PERIODIC MAINTENANCE**

In the event that the enclosure needs to be opened in freezing conditions, a narrow, pointed metallic object such as a screwdriver or chisel, along with a non-metallic device such as a rubber mallet, may be used to remove excessive ice buildup around the door and locking mechanism. A commercial aerosol de-icer spray can be used to free up locks and latches if needed.

#### **5. TECHNICAL ASSISTANCE AND REPAIR SERVICE**

For questions on product repair or if technical assistance is required, contact Charles Technical Support.

847-806-8500

[techserv@charlesindustries.com](mailto:techserv@charlesindustries.com) (email)

<http://www.charlesindustries.com/techserv.htm>

#### **6. WARRANTY & CUSTOMER SERVICE**

Charles Industries LLC offers a one-year warranty on the SHRD56 product. The Charles warranty is limited to the operation of the SHRD56 hardware as described in this documentation and does not cover equipment that may be integrated by a third party. The terms and conditions applicable to any specific sale of the product shall be defined in the resulting sales contract. For questions on warranty or other customer service assistance, contact your Charles Customer Service Representative.

847-806-6300

[mktserv@charlesindustries.com](mailto:mktserv@charlesindustries.com) (email)

[http://www.charlesindustries.com/main/telecom\\_sales\\_support.htm](http://www.charlesindustries.com/main/telecom_sales_support.htm)

7. SPECIFICATIONS

<b>Physical</b>	
Dimensions	42"Hx32"Wx22"D
Weight	SHRD56-051x8GB1: approx. 129 lbs. as shipped, 198 lbs. with equipment SHRD56-051x8GB2: approx. 121 lbs. as shipped, 190 lbs. with equipment SHRD56-601x2GB1: approx. 152 lbs. as shipped, 278 lbs. with equipment SHRD56-601x2GB2: approx. 141 lbs. as shipped, 267 lbs. with equipment SHRD56-601x3GB1: approx. 191 lbs. as shipped, 330 lbs. with equipment SHRD56-601x3GB3: approx. 188 lbs. as shipped, 327 lbs. with equipment SHRD56-601x3GB4: approx. 203 lbs. as shipped, 342 lbs. with equipment SHRD56-601x3GB5: approx. 179 lbs. as shipped, 318 lbs. with equipment SHRD56-601xTGB1: approx. 175 lbs. as shipped, 364 lbs. with equipment SHRD56-601xTGB3: approx. 175 lbs. as shipped, 364 lbs. with equipment SHRD56-601xTGB6: approx. 163 lbs. as shipped; 405 lbs. with equipment SHRD56-601xWGB1: approx. 183 lbs. as shipped, 469 lbs. with equipment SHRD56-601xWGB5: approx. 186 lbs. as shipped, 456 lbs. with equipment SHRD56-601xYGB2: approx. 134 lbs. as shipped, 352 lbs. with equipment
Material	0.125" aluminum
<b>Electrical</b>	
8-position AC Load Center	SHRD56-601xYGB2: Square D QO8L100RB All others: Square D QO816L100RB
AC Surge Suppressor	Raycap AC2080-02-W
AC Disconnect	SHRD56-601x3GB5 and SHRD56-601xWGB5: Raycap RSD-EML-Z12MS-21NN SHRD56-601xTGB6: GE TF60RCP
Meter Socket	SHRD56-051x8GB1, SHRD56-601x3GB3/GB5: Milbank U8874RLLR (ring type) SHRD56-601xxGB1: Milbank U7262-RL-TG (ringless) SHRD56-601x3GB4: Milbank U9581-RL-QG-BLG-AEP (ringless) SHRD56-601xTGB1: Milbank U7262-RL-TG (ringless) SHRD56-601xTGB3: Milbank U8874RLLR (ring type) SHRD56-601xTGB6: Milbank R7043-XL-TG-KK-IL-5T9W (ringless) SHRD56-601xWGB1: Milbank U7262-RL-TG (ringless) SHRD56-601xWGB5: Milbank U8874RLLR (ring type)
Bonding and Grounding	Two 2x8 position ground bars with external ground studs
Cable Entrance	Cutout on bottom of SHRD56 (Refer to Figure 2)
<b>Environmental</b>	
Operating Temp. Range, Inside Enclosure	-40° to +131°F, -40° to 55°C
Operating Temp. Range, Outside Enclosure	-40° to +115°F, -40° to 46°C
Humidity	0 to 95% (non-condensing)
Altitude	Up to 2,000 meters (6560')
<b>Kits and Replacement Parts</b>	
Replacement Gasket	80-005172-A
Composite Mounting Pad	CPAD-S15EXCSH56
18" Plinth Mounting Kit	97-002375x-A
Shim Kit for Leveling	97-000010-0
216 Type Security Tool	07-002070-0
Swing Handle	39-000148-0
2-Wire Door Alarm Switch (White)	17-400314-0
Optional Fan Kit	96-SH5660FNKIT1 (installed at the factory)

**Table 1 SHRD56 Specifications**

Part Number	Color	Touch-up Paint	Supported Equipment
SHRD56-051A8GB1	Off-white	02-200290-0	(5) Ericsson 220x/440x OR (5) Nokia Airscale Micro RRHs OR (2) Nokia Airscale Micro and (1) Nokia AWHHF RRHs  (2) Microlab BK-741W OR (2) Commscope CBC1923 Diplexers (1) Delta 1kW OR (1) Eitek Chameleon 650W power supply
SHRD56-051D8GB1	Classic Texture Gray	02-000629-0	
SHRD56-051F8GB1	Onyx Black	02-000611-0	
SHRD56-051G8GB1	National Park Brown	02-000626-0	
SHRD56-051H8GB1	Hunt Club Green	02-000599-0	
SHRD56-051A8GB2	Off-white	02-200290-0	
SHRD56-051D8GB2	Classic Texture Gray	02-000629-0	
SHRD56-051F8GB2	Onyx Black	02-000611-0	
SHRD56-051G8GB2	National Park Brown	02-000626-0	
SHRD56-601A2GB1	Off-white	02-200290-0	Each of the two RRH mounting locations can support: (1) Ericsson RUS32 OR (1) Ericsson RUS11/12 Each of the two power supply mounting locations can support: (1) Ericsson AC-02 OR (1) Ericsson AC-08 power supplies Other equipment: (1) Charles CFTT OR (1) AFL OptiNID500 OR (1) Corning OptiSheath® fiber box (2) Microlab BK-741 OR (2) Commscope CBC1923Y-43-2X diplexers
SHRD56-601D2GB1	Classic Texture Gray	02-000629-0	
SHRD56-601F2GB1	Onyx Black	02-000611-0	
SHRD56-601G2GB1	National Park Brown	02-000626-0	
SHRD56-601H2GB1	Hunt Club Green	02-000599-0	
SHRD56-601A2GB2	Off-white	02-200290-0	
SHRD56-601D2GB2	Classic Texture Gray	02-000629-0	
SHRD56-601F2GB2	Onyx Black	02-000611-0	
SHRD56-601G2GB2	National Park Brown	02-000626-0	
SHRD56-601H2GB2	Hunt Club Green	02-000599-0	
SHRD56-601A3GB1	Off-white	02-200290-0	Each of the two RRH side mounting locations can support: (1) Nokia AHxxx dual band, (1) Nokia 4x30, (1) Nokia 4x45, OR (3) Nokia Airscale Micro Note: If the 96-000713-0 kit was ordered, then the left side RRH mounting location supports (1) Nokia B41 FWHR Mini Macro RRH instead of the options listed above. The rear RRH mounting location can support (1) Nokia Airscale Micro CBRS RRH Each of the two power supply mounting locations can support: (1) ABB, (1) Nokia, OR (1) Delta power supplies Other equipment: (1) Charles CFTT (2) Commscope CBC1921-DS-2X diplexers
SHRD56-601D3GB1	Classic Texture Gray	02-000629-0	
SHRD56-601F3GB1	Onyx Black	02-000611-0	
SHRD56-601G3GB1	National Park Brown	02-000626-0	
SHRD56-601H3GB1	Hunt Club Green	02-000599-0	
SHRD56-601A3GB3	Off-white	02-200290-0	
SHRD56-601D3GB3	Classic Texture Gray	02-000629-0	
SHRD56-601F3GB3	Onyx Black	02-000611-0	
SHRD56-601G3GB3	National Park Brown	02-000626-0	
SHRD56-601H3GB3	Hunt Club Green	02-000599-0	
SHRD56-601A3GB4	Off-white	02-200290-0	
SHRD56-601D3GB4	Classic Texture Gray	02-000629-0	
SHRD56-601F3GB4	Onyx Black	02-000611-0	
SHRD56-601G3GB4	National Park Brown	02-000626-0	
SHRD56-601H3GB4	Hunt Club Green	02-000599-0	
SHRD56-601A3GB5	Off-white	02-200290-0	
SHRD56-601D3GB5	Classic Texture Gray	02-000629-0	
SHRD56-601F3GB5	Onyx Black	02-000611-0	
SHRD56-601G3GB5	National Park Brown	02-000626-0	
SHRD56-601H3GB5	Hunt Club Green	02-000599-0	

Part Number	Color	Touch-up Paint	Supported Equipment
SHRD56-601ATGB1	Off-white	02-200290-0	Each of the two RRH hanging bracket locations can support: (1) Ericsson 8843, (1) Ericsson 4449, (1) Ericsson 4478, (1) Ericsson 4426, OR (1) Ericsson 4415 Power supply mounting locations can support: (2) Ericsson 6302 OR (4) Ericsson AC-08 Other equipment: (1) Charles CFTT (2) Commscope CBC1921-DS-2X diplexers (1) OPTIONAL: 96-SH5660FNKIT1 fan kit (installed at factory)
SHRD56-601DTGB1	Classic Texture Gray	02-000629-0	
SHRD56-601FTGB1	Onyx Black	02-000611-0	
SHRD56-601GTGB1	National Park Brown	02-000626-0	
SHRD56-601HTGB1	Hunt Club Green	02-000599-0	
SHRD56-601ATGB3	Off-white	02-200290-0	
SHRD56-601DTGB3	Classic Texture Gray	02-000629-0	
SHRD56-601FTGB3	Onyx Black	02-000611-0	
SHRD56-601GTGB3	National Park Brown	02-000626-0	
SHRD56-601HTGB3	Hunt Club Green	02-000599-0	
SHRD56-601ATGB6	Off-white	02-200290-0	
SHRD56-601DTGB6	Classic Texture Gray	02-000629-0	
SHRD56-601FTGB6	Onyx Black	02-000611-0	
SHRD56-601GTGB6	National Park Brown	02-000626-0	
SHRD56-601AWGB1	Off-white	02-200290-0	Each of the two RRH hanging bracket locations can support: (1) Samsung 320W dual band OR (1) Samsung 320W 700M-850M Power supply mounting locations can support (1) Delta 2kW OR (1) ABB CC1600AC55SXZ01 Other equipment: (1) Samsung CBRS (1) Charles CFTT (4) Commscope CBC1921-DS-2X diplexers
SHRD56-601DWGB1	Classic Texture Gray	02-000629-0	
SHRD56-601FWGB1	Onyx Black	02-000611-0	
SHRD56-601GWGB1	National Park Brown	02-000626-0	
SHRD56-601HWGB1	Hunt Club Green	02-000599-0	
SHRD56-601AWGB5	Off-white	02-200290-0	
SHRD56-601DWGB5	Classic Texture Gray	02-000629-0	
SHRD56-601FWGB5	Onyx Black	02-000611-0	
SHRD56-601GWGB5	National Park Brown	02-000626-0	
SHRD56-601HWGB5	Hunt Club Green	02-000599-0	
SHRD56-601AYGB2	Off-white	02-200290-0	(1) Ericsson 4426 or 4419 radio (1) Ericsson 4415 radio (1) Ericsson 8863 radio (1) Ericsson 6308 power supply (1) Primex fiber box (1) Ericsson 6339 BBU
SHRD56-601DYGB2	Classic Texture Gray	02-000629-0	
SHRD56-601FYGB2	Onyx Black	02-000611-0	
SHRD56-601GYGB2	National Park Brown	02-000626-0	
SHRD56-601HYGB2	Hunt Club Green	02-000599-0	

Table 2 SHRD56 Descriptions by Model