

# Charles Universal Broadband Enclosure

## CUBE-RL21221AH5

### General Description and Installation

1. GENERAL INTRODUCTION .....	1
1.1. Document Purpose .....	1
2. PRODUCT DESCRIPTION .....	1
3. CUBE WIRING AND EQUIPMENT.....	3
4. SPECIFICATIONS.....	3

## 1. GENERAL INTRODUCTION

### 1.1. Document Purpose

This document provides additional information for the CUBE-RL21221AH5 of the Charles Industries' Universal Broadband Enclosure (CUBE) product line that is not included in the family document, LT-RL21221xxx. Figure 1 shows a closed front view of the enclosure.

-NOTE-

*Hereafter, the Charles Universal Broadband Enclosure CUBE-21221AH5 will be referred to as the "CUBE."*

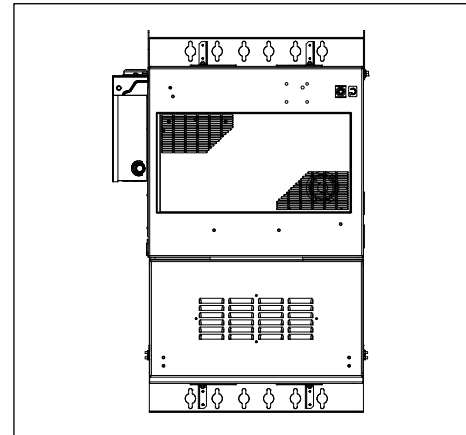

**Figure 1 Front View of the CUBE**

## 2. PRODUCT DESCRIPTION

The CUBE includes an 8-position AC load center. Figure 2 shows the main components of the CUBE.

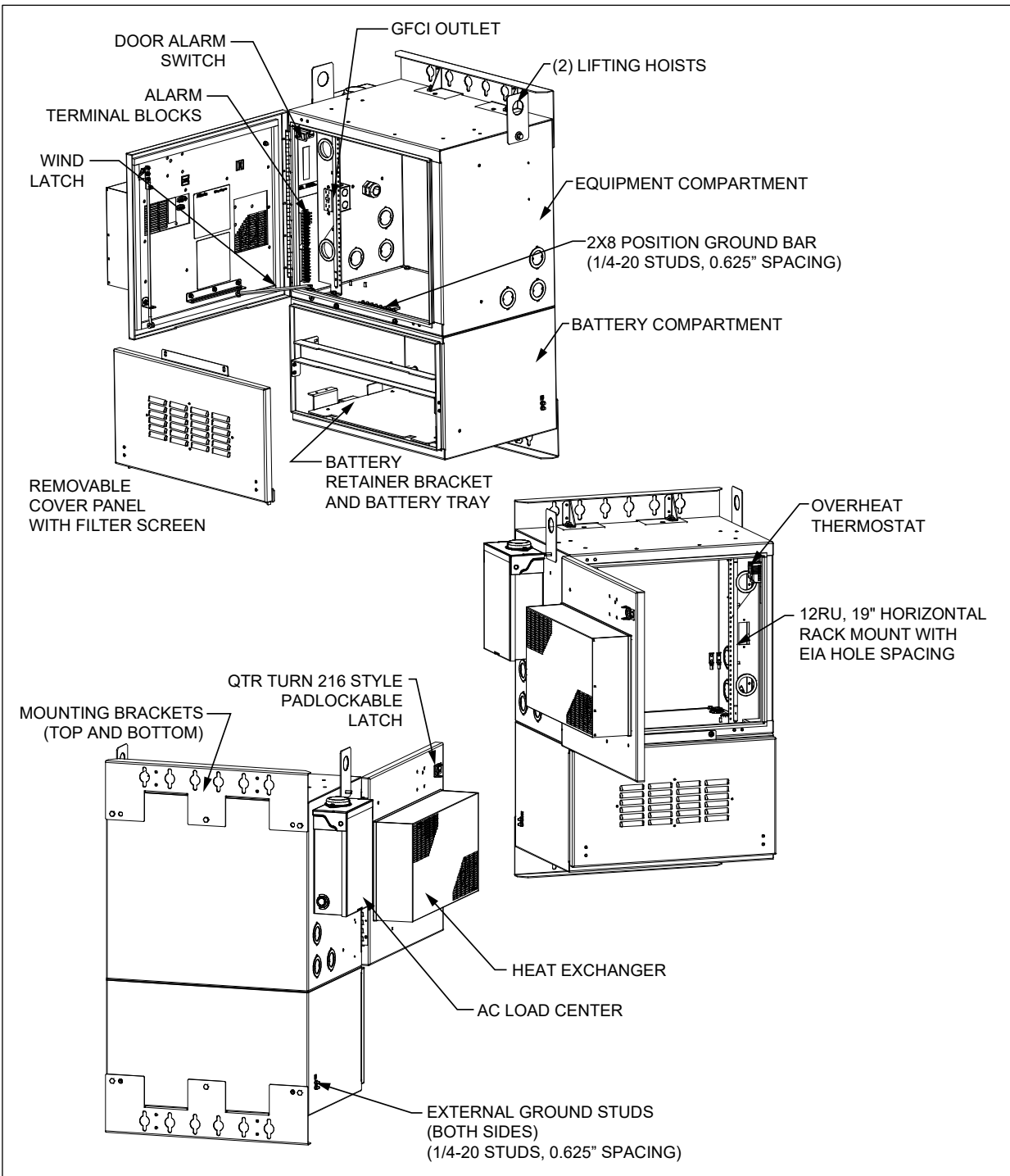

Figure 2 CUBE Components

### 3. CUBE WIRING AND EQUIPMENT

After the CUBE is properly mounted in the desired location, apply No-Ox where bus bar and other 2-hole lug connections will be made. Install ground and power connections. Always ground the equipment first, before making any other connections.

**WARNING** Perform all bonding and grounding connections prior to any electrical and communications connections.

In order to prevent condensation prior to being placed in service, do not remove the desiccant until the CUBE is sealed and power is applied. A basic electrical diagram is shown in Figure 3.

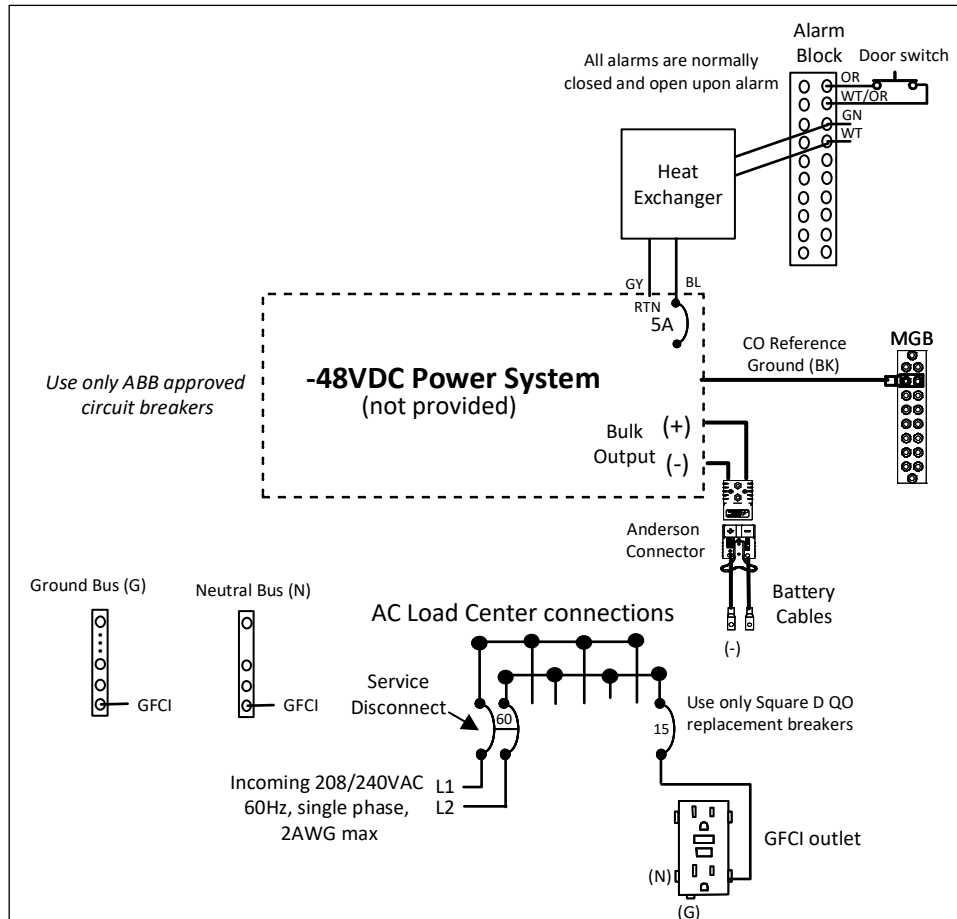

Figure 3 Electrical Diagram

### 4. SPECIFICATIONS

Physical	
Weight	Approx. 118 lbs. as shipped
AC Load Center	Square D QO816L100RB

Table 1 CUBE Specifications (see family document for full list)