

# Charles Universal Broadband Enclosure

## CUBE-RL20721ABx Series

### General Description and Installation

<b>1. GENERAL INTRODUCTION .....</b>	<b>1</b>
1.1. Document Purpose .....	1
1.2. Product Purpose .....	1
1.3. Product Mounting and Location .....	1
<b>2. PRODUCT DESCRIPTION .....</b>	<b>2</b>
<b>3. INSTALLATION .....</b>	<b>3</b>
3.1. Inspecting the Product .....	3
3.2. Following and Using Safety Precautions .....	3
3.3. Obtaining Tools and Equipment .....	3
3.4. Preparing the Installation Site .....	3
3.5. Lifting the CUBE .....	4
3.6. Mounting the CUBE .....	4
3.7. CUBE Wiring and Equipment .....	5
3.8. Conduit Seals .....	6
3.9. Verifying the Installation .....	6
<b>4. PERIODIC MAINTENANCE .....</b>	<b>7</b>
<b>5. TECHNICAL ASSISTANCE AND REPAIR SERVICE .....</b>	<b>7</b>
<b>6. WARRANTY &amp; CUSTOMER SERVICE .....</b>	<b>7</b>
<b>7. SPECIFICATIONS .....</b>	<b>7</b>
7.1. Regulatory Specifications .....	7
7.2. Product Specifications .....	8

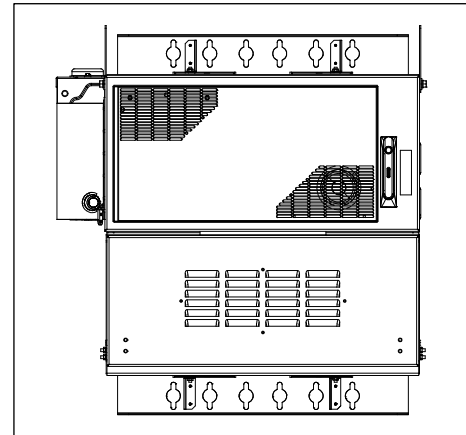

**Figure 1 Front View of the CUBE**

## 1. GENERAL INTRODUCTION

### 1.1. Document Purpose

This document provides general information for the CUBE-RL20721ABx family of Charles Industries' Universal Broadband Enclosures (CUBE) product line. Supplemental documents are supplied with each product that contain information specific to that model. Figure 1 shows a typical front view of the CUBE.

-NOTE-

*Hereafter, the Charles Universal Broadband Enclosure CUBE-RL20721ABx will be referred to as the "CUBE."*

### 1.2. Product Purpose

The CUBE consists of a protective enclosure for an integrated system of electronic components and equipment that can serve fiber and copper interfaces.

### 1.3. Product Mounting and Location

This enclosure is suitable for outside plant-type (OSP) locations and those that may require NEC compliance. The outdoor, weather-resistant CUBE is to be mounted on a wall, pole, H-frame, or pad. The installer connects the power, fiber, and copper connections. Detailed mounting and installation information is covered in Section 3.

## 2. PRODUCT DESCRIPTION

All CUBE's in this series have an equipment and battery compartment. The equipment compartment has 7RU of 19" rack spacing, a 580W 48VDC heat exchanger, and an 8-position AC load center. The battery compartment has one tray made for one -48VDC battery string. The main differences among the members of this product family are the power system included, the battery type supported, and the AC and DC breaker configurations. Table 2 lists all models in this family. Figure 2 shows the dimensions of the CUBE. The supplemental documentation that ships with each CUBE includes a diagram of the CUBE components, a wiring schematic, and descriptions of the battery type, power system, and breaker configuration specific to that model.

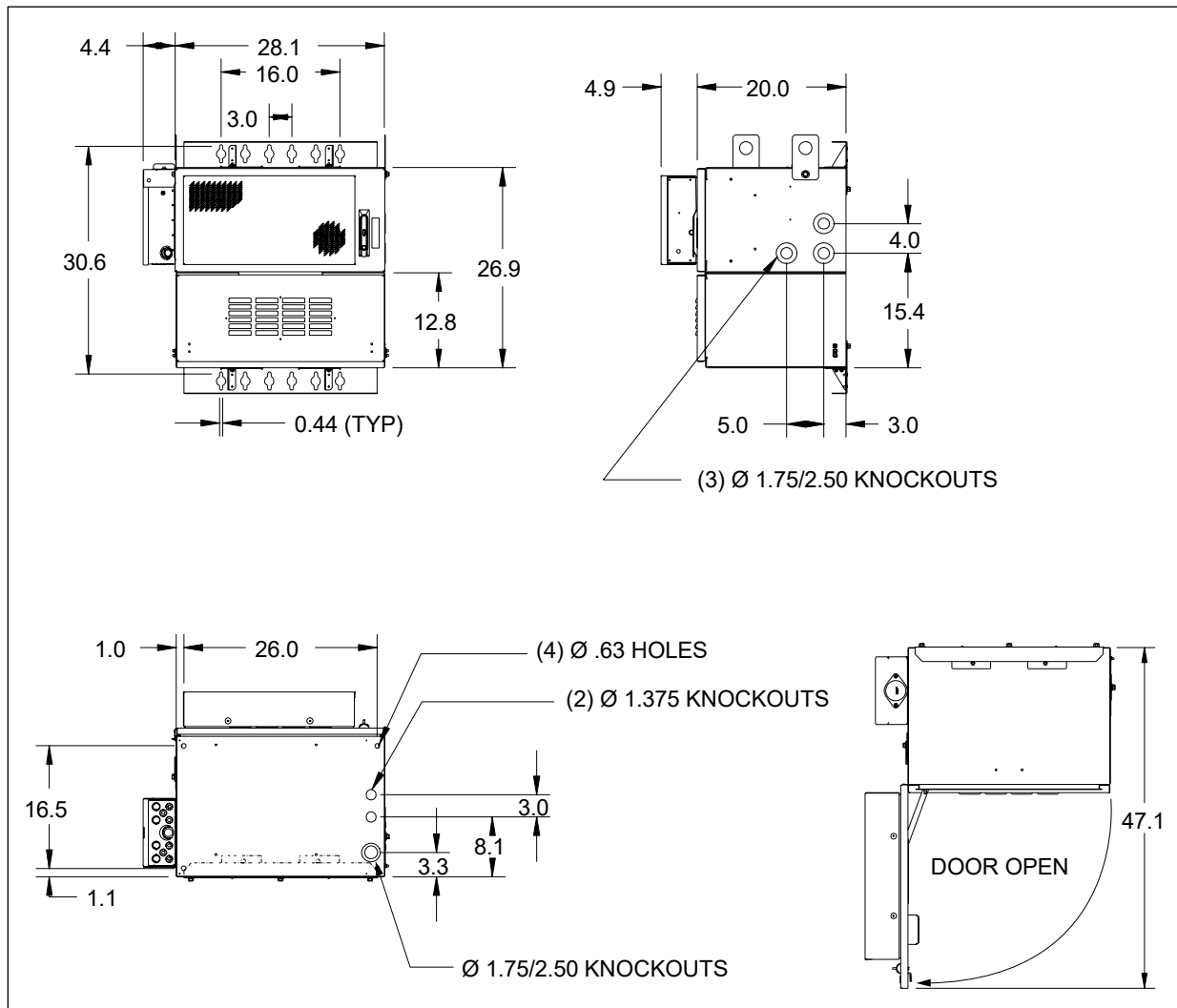

Figure 2 CUBE Dimensions (in inches)

### 3. INSTALLATION

#### 3.1. Inspecting the Product

The CUBE is shipped mounted upright on a skid. Remove the bolts, unpack the unit, and dispose of the packaging material.

*-INSPECTION NOTE-*

*Visually inspect the unit for damages prior to installation. If the equipment was damaged in transit, immediately report the extent of the damage to the transportation company.*

#### 3.2. Following and Using Safety Precautions

Read the following site and safety tips, cautions, and warnings, then proceed with the paragraphs that follow.

- For installation, follow all National Electrical Codes (NEC) ANSI/NFPA 70, local, environmental, workplace, and company codes, safety procedures, and practices.
- Minimum spacing between the accessories and components and the housing for ITE equipment shall be maintained for safe operation of the equipment when installed in accordance with NEC ANSI/NFPA 70.
- Read all instructions, warnings and cautions on the equipment and in the documentation shipped with the product.
- Always connect ground connections first.
- Do not place this product on weak or unstable surfaces which may allow the product to fall, resulting in potentially serious damage(s) to persons or product.
- Only authorized trained personnel shall install the CUBE.
- In windy conditions, be sure to engage the door latches to secure the door in a stationary position.

#### 3.3. Obtaining Tools and Equipment

Obtain the following recommended or needed items for installing the CUBE.

- Sufficient length and quantities of fiber cable (or pigtails)
- Cable scoring, opening, and cutting tools for cable sheathing, shields, wrappings, strength members and buffer tubes
- Wire strippers
- Crimpers
- Cable, tube, wire, and fiber cleaning materials
- Protective and/or insulated work gloves
- Safety glasses
- Tape measure
- Marking utensil
- #6 ground wire or rod and earth ground materials
- Bond strap (optional, from cable bond clamp to bond post)
- Any exterior cable strain relief, per company practice
- Slotted, hex, and Phillips screwdrivers
- Torque wrench
- Assorted cable ties, clips, or fasteners (optional)
- Can wrench (216 type tool)
- Derrick for lifting
- Level

#### 3.4. Preparing the Installation Site

Observe the following site preparation recommendations.

- Leave adequate horizontal and vertical space between multiple installations to allow for proper cable access, as well as enough room around the enclosure to open the door(s).
- The site must meet minimal personnel and equipment safety requirements.
- The distance from the cable entry point should be consistent with local installation practices.
- The pad, wall, pole, or H-frame must be able to support the weight of the CUBE.
- Run all fiber and copper facilities to the site.

### 3.5. Lifting the CUBE

See the supplemental documentation for CUBE weight. Charles recommends the following procedure for lifting the CUBE.

#### 3.5.1. Required Equipment

- One derrick (crane) capable of lifting the CUBE
- Spreader bar
- Two lifting slings or chains with each having a 2,500 lbs. capacity
- Connecting links to attach slings to the CUBE's lifting brackets
- 75-ft. long tagline rope

Insert the lifting sling connecting links securely through each of the lifting brackets as shown in Figure 3.

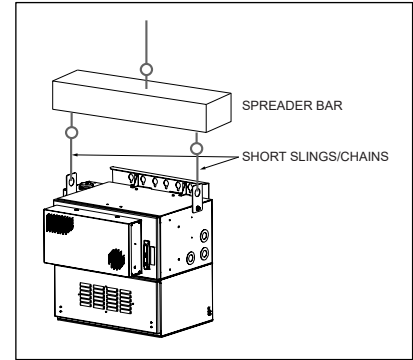

Figure 3 Lifting the CUBE

#### 3.5.2. Warnings and Specific Safety Precautions

	<b>WARNING</b>	<b>Improper hoisting equipment and unsafe lifting procedures can result in serious injury or death. Because of the added risk of injury or damage, do not lift enclosures with batteries installed.</b>
--	----------------	---

Observe the following local safety procedures when performing the tasks in this section.

- Keep the CUBE away from any power lines.
- Keep bystanders away from the work operations at all times.
- Only trained operators shall operate the crane for lifting and setting the CUBE.
- Do not suspend loads over people or equipment.
- All persons working with hoisting equipment shall wear standard safety gear according to local practices including safety helmets and steel-toed shoes.
- Do not operate the hoisting equipment until all stabilizers are extended and in firm contact with the ground or adequate support structure.
- Do not attempt to retract or extend the stabilizers while a load is suspended.

### 3.6. Mounting the CUBE

Enclosures can be mounted on a pad, wall, H-frame or pole. Refer to Figure 2 for mounting dimensions for positioning mounting hardware. Charles recommends using a minimum SAE Grade 2, corrosion-resistant bolts, washers, and nuts for all mounting applications. Use 1/2" diameter hardware for pad mounting and 3/8" diameter hardware for all other mounting styles. Bolts need to be of sufficient length depending on which type of mounting is used.

The CUBE ships with the mounting brackets facing toward the center. For wall, H-frame, or pole mounting, reorient the brackets prior to mounting as shown in Figure 2, and torque the mounting bracket screws to a value of 180 in-lbs. The images in this document show the brackets in the correct orientation for wall, pole, and H-frame mounting.

- A minimum of 3/4" thick plywood or similar surface is required for wall mounting.
- Charles kit 97-CABPMTKIT is available for pole-mount applications.
- Charles kit 97-001971-A contains hardware for mounting to H-frame unistruts.
- Use Charles kit 97-002116-A for mounting the CUBE to a pad. The kit includes a 10" plinth, gasket, and hardware for mounting the CUBE to the plinth.

#### 3.6.1. Torque Requirements

Torque all hardware as shown below (unless otherwise noted). These values apply to SAE Grade 1 & 2 Low Carbon Steel, ASTM A307 Low Carbon Steel, and Stainless Steel Grade 18-8.

Thread Size	In-lbs	Ft-lbs
4-40	4±10%	
6-32	8±10%	
8-32	16±10%	
10-32	26±10%	
12-24	50±10%	
1/4-20/M6	60±5%	5±5%
5/16-18	125±5%	10.4±5%
3/8-16	180±5%	15.0±5%
1/2-13	500±2%	41.7±2%
5/8-11	1000±1%	83.3±1%

### 3.7. CUBE Wiring and Equipment

After the CUBE is properly mounted in the desired location, apply No-Ox where bus bar and other 2-hole lug connections will be made. Install ground and power connections. Always ground the equipment first, before making any other connections.

	<b>WARNING</b>	<b>Perform all bonding and grounding connections prior to any electrical and communications connections.</b>
---	----------------	--

In order to prevent condensation prior to being placed in service, do not remove the desiccant until the CUBE is sealed and power is applied. See the supplemental documents for electrical diagrams.

#### 3.7.1. Ground Connection

Use the 2x8 position ground bar provided in the equipment compartment for all grounding of internal equipment. Stack hardware as shown in Figure 4. External ground lugs are available on the sides of the CUBE for connecting a site ground wire.

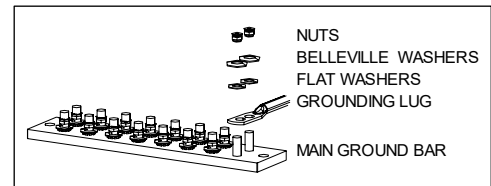
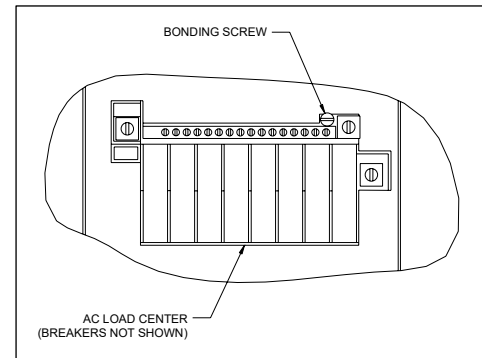

**Figure 4**  
**Ground Bar Hardware Stack**

#### 3.7.2. AC Voltage Connection

The incoming AC voltage is single phase 208/240V, 60Hz, except for the RL20721AB5, which runs off of 120VAC. The installer connects the voltage to the main breaker on the left side of the 8-position load center; the neutral wire and ground wires are then connected to their respective buses. Use wire that is sized per National Electrical Code NFPA70 table 310.16.

The AC load center is configured as a sub panel with separate neutral and ground buses. If the load center needs to be configured as a main panel, the green bonding screw inside the load center must be screwed down to connect the buses. Figure 5 shows the location of the bonding screw.



**Figure 5**  
**Bonding Screw Location**

#### 3.7.3. Battery Connection

	<b>WARNING</b>	<p><b>Always turn off battery breakers or disconnect blue Anderson connectors prior to servicing batteries.</b></p> <p><b>Disregard the (+) and (-) polarity markings on the blue Anderson connectors. The cable assemblies are used on both +24VDC and -48VDC products, so markings on the Anderson connectors are misleading.</b></p> <p><b>If using VRLA batteries, ensure that the power system is set up for VRLA batteries with temperature compensation enabled.</b></p>
---	----------------	---

Verify the polarity of the cables prior to terminating them to the batteries. Ensure the battery terminations are properly insulated to avoid shorting prior to terminating to the batteries.

1. Disconnect the Anderson connector(s) or switch off the battery breaker located in the battery compartment.
2. Remove the battery retainer bracket by removing the hardware.
3. If replacing batteries, disconnect battery cables from terminals and loosen the battery retaining strap(s).
4. VRLA Only: Remove the battery temperature probe.
5. Remove the interconnecting straps from the batteries. Remove batteries.
6. Carefully position the new batteries on the battery tray. Connect the interconnecting straps to each battery string.
7. VRLA Only: Replace battery temperature probe to the closest battery.
8. Connect the battery cables to the appropriate terminals.
9. Secure the battery retaining straps and reinstall the battery retainer brackets using hardware from step 2.
10. Properly manage the battery cables.
  - o Ensure that the bending radius is not less than 5x the cable diameter (e.g. 4/0 battery cable = 4 inch bend radius).
  - o Use as few bends as possible between the two termination points.
  - o Do not bend the cable at the termination points.
11. Reconnect the Anderson connector(s) or switch on the battery breaker.

**Notes:**

- Anderson connectors and battery breakers terminate at the power shelf.
- NiCD Only: NiCd batteries require nickel plated lugs. Charles cables are equipped with the correct nickel plating.
- VRLA Only: Ensure temperature compensation probes are installed per power system guidelines.
- Ensure back up battery amperage is inputted into the power system controller per power system guidelines.
- Ensure float voltage is set per power system and battery guidelines.
- Ensure all battery terminations and bus bars have No Ox applied.
- Refer to the battery manufacturer’s documentation for proper battery installation and maintenance information.

**3.7.4. Heat Exchanger Operation**

The 750W DC powered heat exchanger in the equipment compartment has a fan speed controller and includes an internal and an external fan. Both fans’ speed increases with increasing internal cabinet temperature. Fans and heat exchanger settings are defined below and are based off of the cabinet interior temperature. The maximum airflow amount supplied to the equipment by the heat exchanger is 147CFM.

Setting	Internal	External
Turn-on Setting (5°C Differential)	0°C	30°C
Medium Temp Setting	30°C	35°C
High Temp Setting	45°C	50°C
High Temp Alarm Setting	70°C	N/A
Low Temp Alarm Setting	-40°C	N/A

For more information, refer to the heat exchanger documentation found inside the CUBE.

-NOTE-

*Changing the speed controller default factory set points can lead to system performance issues, such as equipment failures, increased power use, unnecessary alarms, noise, condensation build up, fan failure caused by excessive runtimes and vibration. Avoid placing items in front of the heat exchanger’s return and supply vents. Maintain a minimum of 6” clearance to enable proper air flow.*

**3.7.5. Overheat Thermostat**

The CUBE is equipped with an overheat (high temperature) alarm thermostat in the equipment compartment that provides a normally closed connection. The overheat alarm is factory set at 60°C and opens the connection if this temperature is exceeded.

**Note: the overheat thermostat is not available on the RL20721ABJ.**

-NOTE-

*Changing the overheat (high-temp) thermostat default factory set points can lead to unnecessary alarms or system performance issues, such as equipment failures as a result of unreported alarms.*

**3.7.6. Alarm Block Connections**

A 10-position, labeled alarm block monitors components in the equipment compartment. See the electrical diagram for information about alarm connections. All alarm connections are normally closed and will open upon alarm.

**3.7.7. Fiber and Copper Entry**

Fiber and copper enters the CUBE through the 1.75”/2.50” knockouts on the bottom and side of the CUBE as shown Figure 2. The 1.75” knockouts accommodate 1.25” conduit fittings, and the 2.50” knockouts accommodate 2” conduit fittings.

**3.8. Conduit Seals**

All internal and external conduit openings on the CUBE must be completely sealed with a duct seal compound to prevent moisture from entering the equipment compartment. The battery compartment must be internally sealed from the equipment compartment to prevent outgassing from the batteries into the equipment compartment. Use a moldable, flame-retardant putty style duct seal material. Do not use an expanding foam seal. Mold the putty so that the open space around the wire or conduit is completely sealed, as shown in Figure 6. If the openings must be accessed at any time, remove the putty and set it aside. When work is complete, re-mold the putty to re-seal the opening.

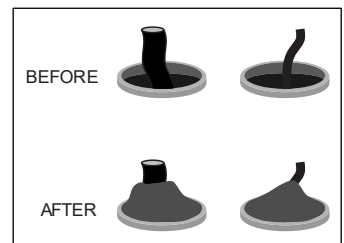

**Figure 6 Applying Putty Seal**

**3.9. Verifying the Installation**

Verify that earth ground and all grounding and bonding is complete and functional. After verifying that all installer connections are secure and complete, apply voltage.

## 4. PERIODIC MAINTENANCE

In the event that the enclosure must be opened in freezing conditions, use a narrow, pointed metallic object such as a screwdriver or chisel, along with a non-metallic device like a rubber mallet, to remove excessive ice buildup around the door and locking mechanism. A commercial aerosol de-icer spray can be used to free up locks and latches if needed. Use protective gloves and safety glasses when applying de-icer sprays.

Periodic cleaning of the filter screens is important to maintain proper ventilation. To clean the filter screens, remove the four nuts on each screen and take out the screens. Use a soft brush or hose to remove any debris from the screen. Once clean, replace the screens using the four nuts removed previously.

Reset the GFCI duplex receptacle periodically to ensure it is working. The unit meets UL-943, which requires an auto-monitoring (self-testing) feature. A flashing or solid red LED indicates a fault. If the unit continues to show a fault after resetting, replace the unit.

The heat exchanger requires no scheduled maintenance other than cleaning the fans and heat exchanger core if they become contaminated with dust or residue. Remove the cover by removing the screws on the outside. Examine periodically to determine the required cleaning periods based on the installed environmental conditions.

## 5. TECHNICAL ASSISTANCE AND REPAIR SERVICE

For questions on product repair or if technical assistance is required, contact Charles Technical Support.

847-806-8500

[techserv@charlesindustries.com](mailto:techserv@charlesindustries.com) (email)

<http://www.charlesindustries.com/techserv.htm>

## 6. WARRANTY & CUSTOMER SERVICE

Charles Industries LLC offers a one-year warranty on the CUBE product. The Charles warranty is limited to the operation of the CUBE hardware as described in this documentation and does not cover equipment which may be integrated by a third party. The terms and conditions applicable to any specific sale of product shall be defined in the resulting sales contract. For questions on warranty or other customer service assistance, contact your Charles Customer Service Representative.

847-806-6300

[mktserv@charlesindustries.com](mailto:mktserv@charlesindustries.com) (email)

[http://www.charlesindustries.com/main/telecom\\_sales\\_support.htm](http://www.charlesindustries.com/main/telecom_sales_support.htm)

## 7. SPECIFICATIONS

### 7.1. Regulatory Specifications

- Designed to meet GR-487
- GFCI: UL-943 Listed

If CUBEs are field-modified, a customer provided ETL field evaluation of the modified components may be required to re-establish ETL certification to UL standards. Consult local jurisdictions for guidance on a site-by-site basis.

**7.2. Product Specifications**

<b>Physical</b>	
Dimensions	27"Hx28"Wx20"D
19" Equipment Rack Space and Hole Spacing	12.25" (7RU) EIA spacing with tapped #12-24 mounting holes
Battery Tray Size	10.5"Hx20.8"Wx15.8"D
Maximum Supported Weight	Rack Rails: 77 lbs. Battery Tray: 400 lbs.
Materials	0.125 aluminum
Color	Off-white
<b>Electrical</b>	
AC Load Center	Square D QO816L100RB
Bonding and Grounding	One 2x8 Position Ground Bar, Two external ground locations
Cable Entrance	Refer Figure 2 or section 3.7.7
<b>Thermal</b>	
Heat Exchanger	750W, 48VDC, Vikinor VHC-030-DC
Maximum Heat Dissipation	700W@19°C above ambient with solar
<b>Environmental</b>	
Operating Temp. Range, Outside Enclosure	-40° to +115°F, -40° to 46°C
Operating Temp Range, Inside Enclosure	-40° to +149°F, -40° to 65°C
Humidity	0 to 95% (non-condensing)
Altitude	Up to 2,000 meters (6560 feet)
<b>Kits and Replacement Parts</b>	
Touch-up Paint	02-000290-0
216 Type Security Tool	07-002070-0
H-Frame Mounting Kit	97-001971-A
Plinth Mounting Kit	97-002116-A
Pole Mounting Kit	97-CABPMTKIT
Swing Handle	38-200322-0
Overheat Thermostat	99-004548-0
2-Wire Door Alarm Switch	17-400314
GFCI Outlet	15A, 04-100207-0

**Table 1 CUBE Specifications**