

Charles Universal Broadband Enclosure

CUBE-RL20721AB4

General Description and Installation

1. GENERAL INTRODUCTION	1
1.1. Document Purpose	1
2. PRODUCT DESCRIPTION	1
3. CUBE WIRING AND EQUIPMENT.....	3
3.1. AC Voltage Connection.....	4
3.2. -48VDC Power System.....	4
4. SPECIFICATIONS.....	4

1. GENERAL INTRODUCTION

1.1. Document Purpose

This document provides additional information for the CUBE-RL20721AB4 of the Charles Industries' Universal Broadband Enclosure (CUBE) product line that is not included in the family document, LT-RL20721ABx. Figure 1 shows a closed front view of the enclosure.

-NOTE-

Hereafter, the Charles Universal Broadband Enclosure CUBE-RL20721AB4 will be referred to as the "CUBE."

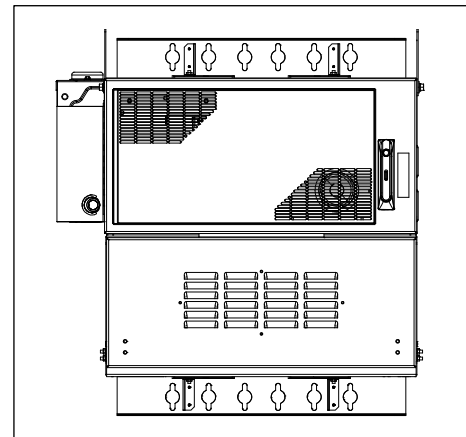

Figure 1 Front View of the CUBE

2. PRODUCT DESCRIPTION

The CUBE includes an ABB Infinity D -48VDC power shelf with a controller and three 50A rectifiers. The battery tray supports one string of Saft Tel.X 80 or 100Ah NiCd batteries. Figure 2 shows the main components of the CUBE.

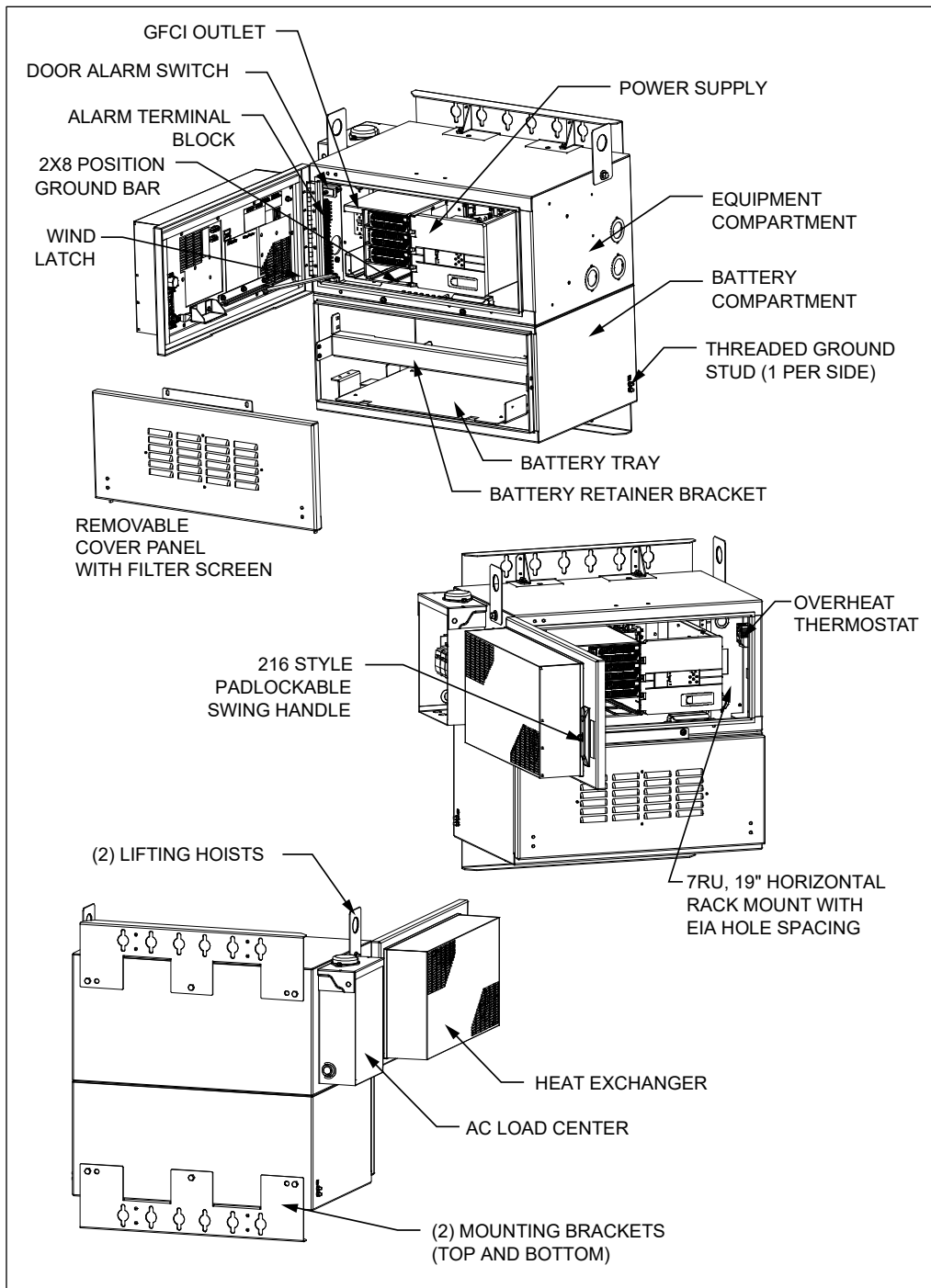

Figure 2 CUBE Components

3. CUBE WIRING AND EQUIPMENT

After the CUBE is properly mounted in the desired location, apply No-Ox where bus bar and other 2-hole lug connections will be made. Install ground and power connections. Always ground the equipment first, before making any other connections.

	WARNING	Perform all bonding and grounding connections prior to any electrical and communications connections.
--	----------------	--

In order to prevent condensation prior to being placed in service, do not remove the desiccant until the CUBE is sealed and power is applied. A basic electrical diagram is shown in Figure 3.

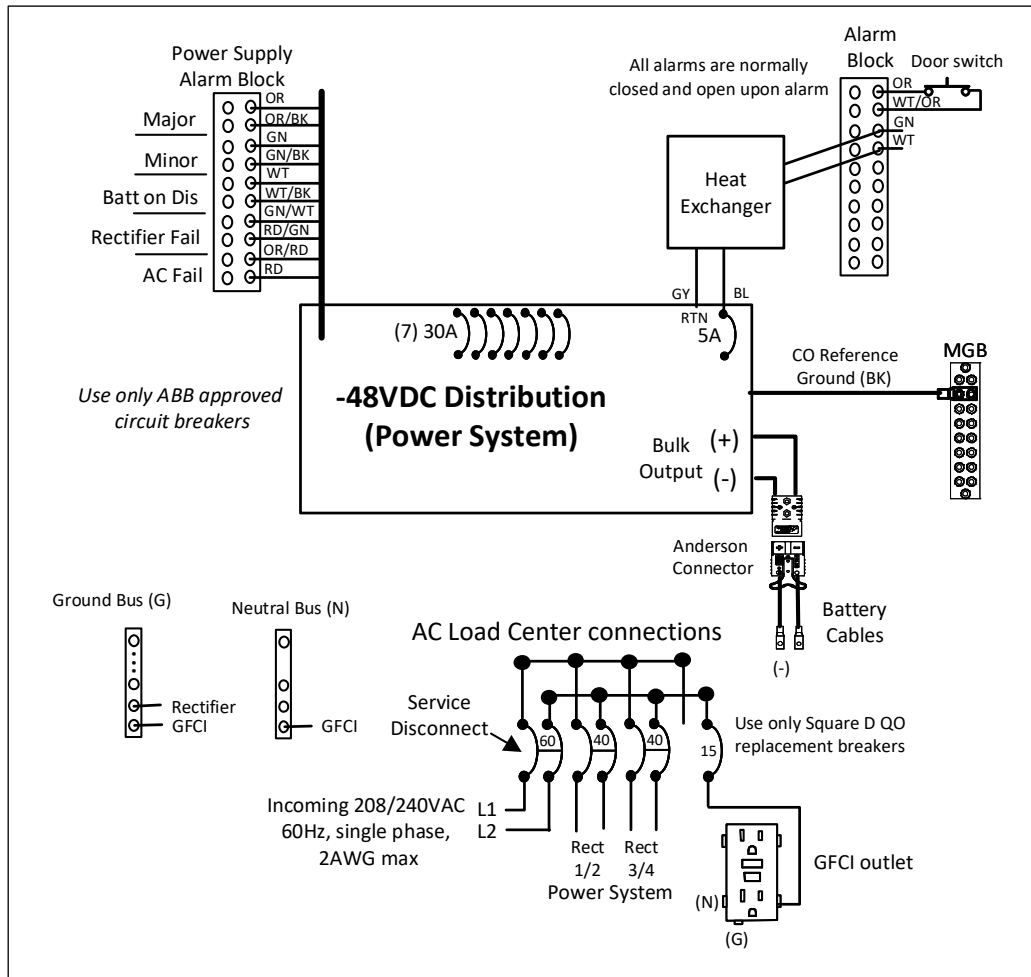

Figure 3 Electrical Diagram

3.1. AC Voltage Connection

The installer connects the utility’s incoming single phase 208/240VAC (60Hz) to the 60A service disconnect in the AC load center. The two 40A breakers control the power to the three rectifier slots in the ABB power shelf. The 15A circuit breaker is connected to the GFCI receptacle.

3.2. -48VDC Power System

The CUBE is equipped with a ABB Infinity D power system that has three 50A rectifiers, a controller, a 1RU -48VDC 19” distribution shelf and an alarm cable wired to the alarm terminal block. The distribution shelf has 10 bullet breaker positions (8 are populated, 2 are free). Battery cables connect to the bulk output.

Refer to the ABB power supply documentation located inside the CUBE for information regarding the power supply operations and configuration.

4. SPECIFICATIONS

Physical	
Weight	Approx. 160 lbs. as shipped
Electrical	
Power System	-48VDC, ABB Infinity D CC109161320 (3) 50A Rectifiers ABB CC109158878
Supported Batteries	-48VDC NiCd: Saft Tel.X 80 (80-94690-02) or Saft Tel.X 100 (80-94692-02)

Table 1 CUBE Specifications (see family document for full list)