

Charles Universal Broadband Enclosure

CUBE-RL22021DB1 and CUBE-RL22021DB2

General Description and Installation

1. GENERAL INTRODUCTION	1
1.1. Document Purpose	1
1.2. Product Purpose	1
1.3. Product Mounting and Location	1
2. PRODUCT DESCRIPTION	2
3. INSTALLATION	4
3.1. Inspecting the Product	4
3.2. Following and Using Safety Precautions	4
3.3. Obtaining Tools and Equipment	4
3.4. Preparing the Installation Site	4
3.5. Lifting the CUBE	5
3.6. Mounting the CUBE	5
3.8. CUBE Wiring and Equipment	6
3.9. Conduit Seals	9
3.10. Verifying the Installation	9
4. PERIODIC MAINTENANCE	9
5. TECHNICAL ASSISTANCE AND REPAIR SERVICE	9
6. WARRANTY & CUSTOMER SERVICE	9
7. SPECIFICATIONS	10
7.1. Regulatory Specifications	10
7.2. Product Specifications	10

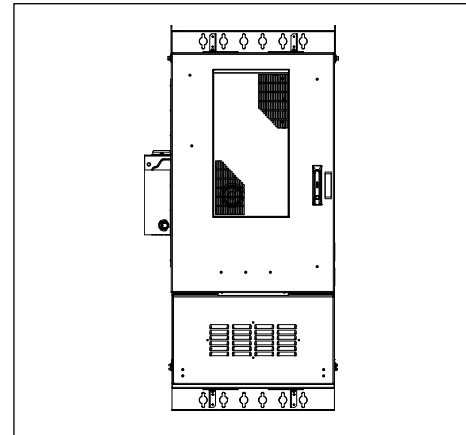

Figure 1 Front View of the CUBE

1. GENERAL INTRODUCTION

1.1. Document Purpose

This document provides general information for the CUBE-RL22021DB1 and CUBE-RL22021DB2 of the Charles Industries' Universal Broadband Enclosure (CUBE) product line. Figure 1 shows a closed front view of the enclosure.

-NOTE-

Hereafter, the Charles Universal Broadband Enclosure CUBE-RL22021DB1 and CUBE-RL22021DB2 will be referred to as the "CUBE."

1.2. Product Purpose

The CUBE consists of a protective enclosure for an integrated system of electronic components and equipment that can serve fiber and copper interfaces.

1.3. Product Mounting and Location

This enclosure is suitable for outside plant-type (OSP) locations and those that may require NEC compliance. The outdoor, weather-resistant CUBE is to be mounted on a wall, pole, H-frame, or pad. The installer connects the power, fiber, and copper connections. Detailed mounting and installation information is covered in Section 3.

2. PRODUCT DESCRIPTION

The CUBE includes an equipment compartment with 20RU of 19" horizontal rack spacing, a 750W -48VDC heat exchanger, and an 8-position AC load center. The RL22021DB2 also includes an ABB Infinity D power shelf. The CUBE also includes a battery compartment that supports one string of customer supplied 48V Saft Tel.X 80 or Saft Tel.X 100 NiCd batteries.

Figure 2 shows the CUBE dimensions and Figure 3 shows the main components of the CUBE.

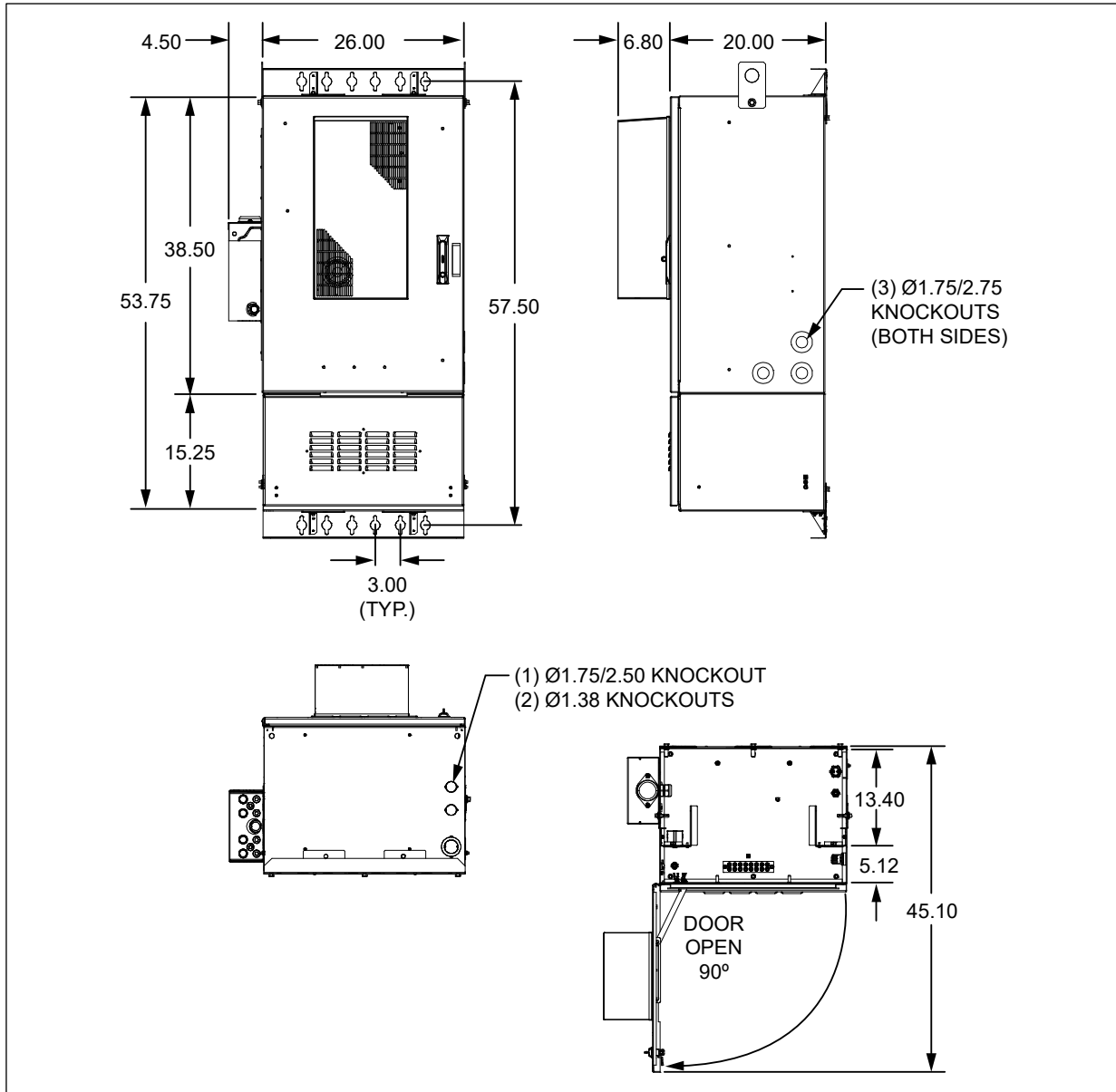

Figure 2 CUBE Dimensions (in inches)

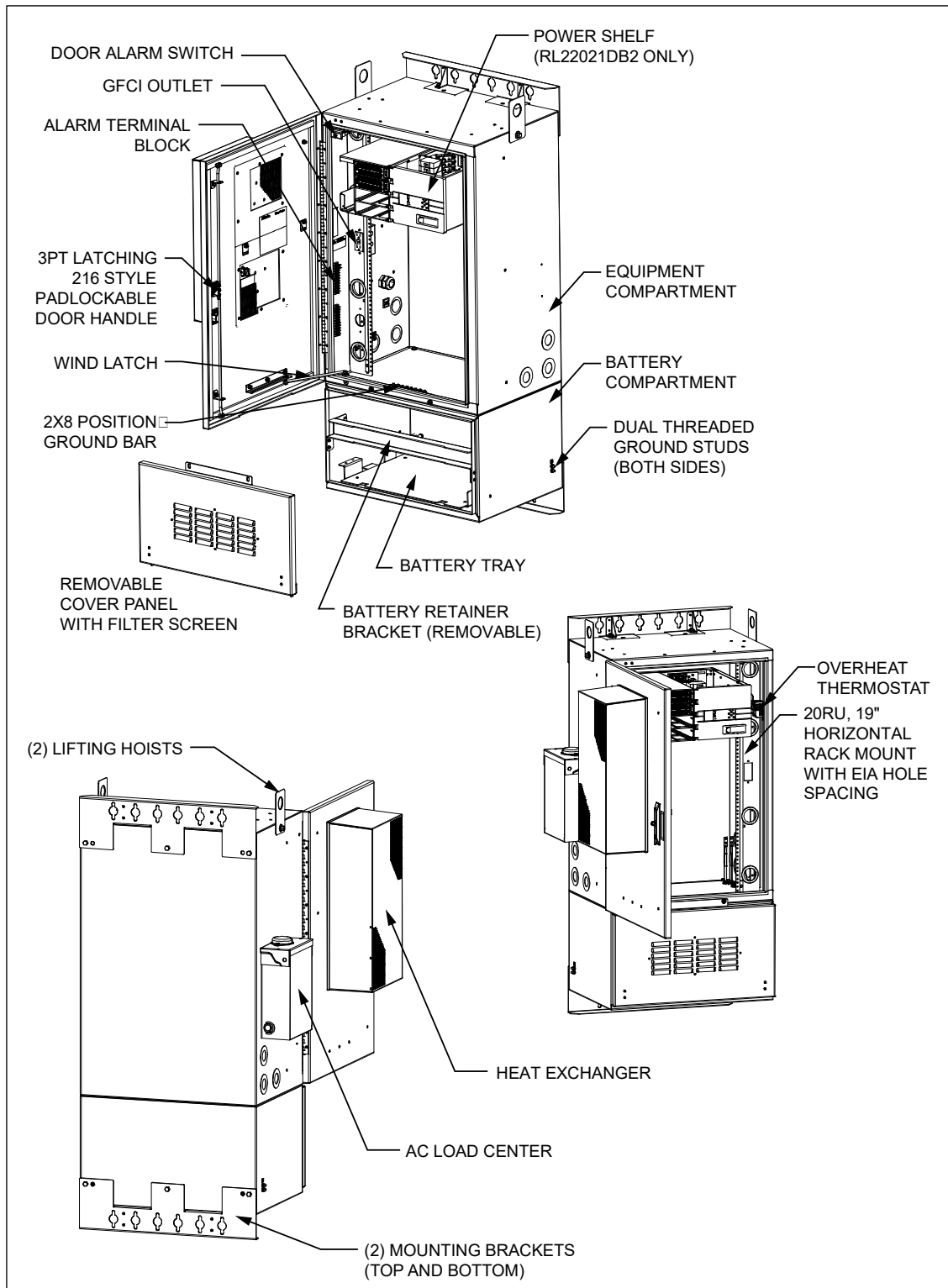

Figure 3 CUBE Components

3. INSTALLATION

3.1. Inspecting the Product

The CUBE is shipped mounted upright on a skid. Remove the bolts, unpack the unit, and dispose of the packaging material.

-INSPECTION NOTE-

Visually inspect the unit for damages prior to installation. If the equipment was damaged in transit, immediately report the extent of the damage to the transportation company.

3.2. Following and Using Safety Precautions

Read the following site and safety tips, cautions, and warnings, then proceed with the paragraphs that follow.

- For installation, follow all National Electrical Codes (NEC) ANSI/NFPA 70, local, environmental, workplace, and company codes, safety procedures, and practices.
- Minimum spacing between the accessories and components and the housing for ITE equipment shall be maintained for safe operation of the equipment when installed in accordance with NEC ANSI/NFPA 70.
- Read all instructions, warnings and cautions on the equipment and in the documentation shipped with the product.
- Always connect ground connections first.
- Do not place this product on weak or unstable surfaces which may allow the product to fall, resulting in potentially serious damage(s) to persons or product.
- Only authorized trained personnel shall install the CUBE.
- In windy conditions, be sure to engage the door latches to secure the door in a stationary position.

3.3. Obtaining Tools and Equipment

Obtain the following recommended or needed items for installing the CUBE.

- Sufficient length and quantities of fiber cable (or pigtails)
- Cable scoring, opening, and cutting tools for cable sheathing, shields, wrappings, strength members and buffer tubes
- Wire strippers
- Crimpers
- Cable, tube, wire, and fiber cleaning materials
- Protective and/or insulated work gloves
- Safety glasses
- Tape measure
- Marking utensil
- #6 ground wire or rod and earth ground materials
- Bond strap (optional, from cable bond clamp to bond post)
- Any exterior cable strain relief, per company practice
- Slotted, hex, and Phillips screwdrivers
- Torque wrench
- Assorted cable ties, clips, or fasteners (optional)
- Can wrench (216 type tool)
- Derrick for lifting
- Level

3.4. Preparing the Installation Site

Observe the following site preparation recommendations.

- Leave adequate horizontal and vertical space between multiple installations to allow for proper cable access, as well as enough room around the enclosure to open the door(s).
- The site must meet minimal personnel and equipment safety requirements.
- The distance from the cable entry point should be consistent with local installation practices.
- The pad, pole, wall, or H-frame must be able to support the weight of the CUBE.
- Run all fiber and copper facilities to the site.

3.5. Lifting the CUBE

See Table 1 for CUBE weight. Charles recommends the following procedure for lifting the CUBE.

	WARNING	Prior to lifting, remove the lifting brackets that hold the mounting gasket in place. Set aside the gasket, and then replace the brackets. Failure to do so can result in a failure of the lifting bracket assembly.
--	----------------	---

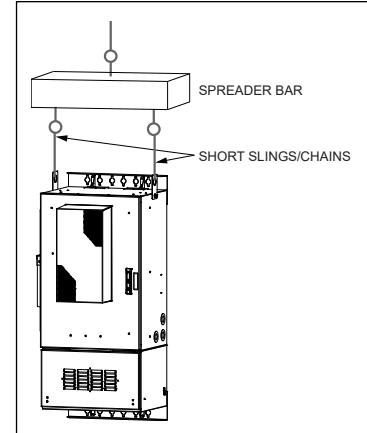

Figure 4 Lifting the CUBE

3.5.1. Required Equipment

- One derrick (crane) capable of lifting the CUBE
- Spreader bar
- Two lifting slings or chains with each having a 2,500 lbs. capacity
- Connecting links to attach slings to the CUBE’s lifting brackets
- 75-ft. long tagline rope

Insert the lifting sling connecting links securely through each of the lifting brackets as shown in Figure 4.

3.5.2. Warnings and Specific Safety Precautions

	WARNING	Improper hoisting equipment and unsafe lifting procedures can result in serious injury or death. Because of the added risk of injury or damage, do not lift enclosures with batteries installed.
--	----------------	---

Observe the following local safety procedures when performing the tasks in this section.

- Keep the CUBE away from any power lines.
- Keep bystanders away from the work operations at all times.
- Only trained operators shall operate the crane for lifting and setting the CUBE.
- Do not suspend loads over people or equipment.
- All persons working with hoisting equipment shall wear standard safety gear according to local practices including safety helmets and steel-toed shoes.
- Do not operate the hoisting equipment until all stabilizers are extended and in firm contact with the ground or adequate support structure.
- Do not attempt to retract or extend the stabilizers while a load is suspended.

3.6. Mounting the CUBE

3.6.1. Torque Requirements

Torque all hardware as shown below (unless otherwise noted). These values apply to SAE Grade 1 & 2 Low Carbon Steel, ASTM A307 Low Carbon Steel, and Stainless Steel Grade 18-8.

Thread Size	In-lbs	Ft-lbs
4-40	4±10%	
6-32	8±10%	
8-32	16±10%	
10-32	26±10%	
12-24	50±10%	
1/4-20/M6	60±5%	5±5%
5/16-18	125±5%	10.4±5%
3/8-16	180±5%	15.0±5%
1/2-13	500±2%	41.7±2%
5/8-11	1000±1%	83.3±1%

3.6.2. Pole, Wall, or H-frame Mounting

Charles recommends using a minimum SAE Grade 2, 3/8” diameter corrosion-resistant bolts, washers and nuts for all mounting applications. Bolts need to be of sufficient length depending on which type of mounting is used.

The CUBE ships with the mounting brackets facing toward the center. For wall, H-frame, or pole mounting, reorient the brackets prior to mounting as shown in Figure 2, and torque the mounting bracket screws to a value of 180 in-lbs. Images in this document show the mounting brackets in this orientation.

A minimum of 3/4” thick plywood or similar surface is required for wall mounting

Charles kit 97-CABPMTKIT is available for pole-mount applications.

Charles kit 97-001971-A contains hardware for mounting to H-frame unistruts.

3.6.3. Pad Mounting

Charles kit 97-002176-A is available for mounting the CUBE to a pad. The kit includes a 10” plinth, gasket, and hardware for mounting the CUBE to the plinth. Should the gasket become damaged during installation, a replacement can be ordered under part number 80-005135-A.

Charles recommends using 1/2” anchor bolts for mounting to the pad. Mounting hardware is customer supplied.

3.7. CUBE Wiring and Equipment

After the CUBE is properly mounted in the desired location, apply No-Ox where bus bar and other 2-hole lug connections will be made. Install ground and power connections. Always ground the equipment first, before making any other connections.

	WARNING	Perform all bonding and grounding connections prior to any electrical and communications connections.
--	----------------	--

In order to prevent condensation prior to being placed in service, do not remove the desiccant until the CUBE is sealed and power is applied. Basic electrical diagrams are shown in Figures 5 and 6.

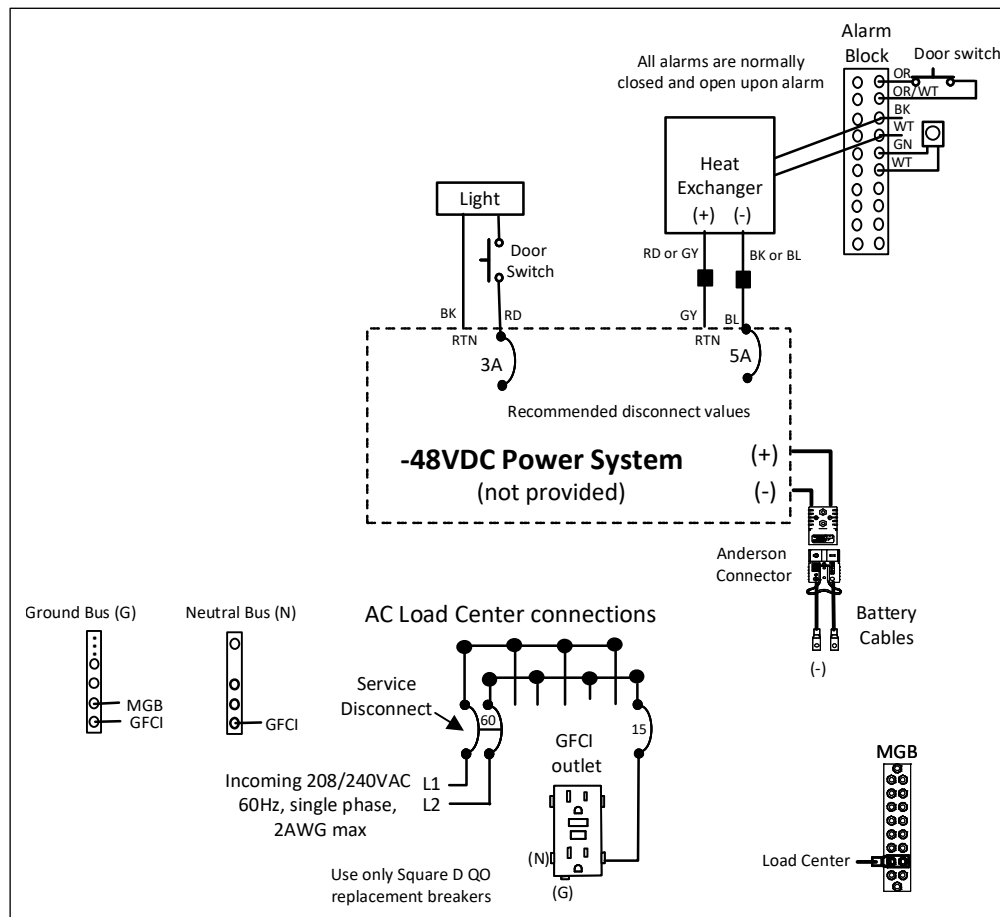

Figure 5 RL22021DB1 Electrical Diagram

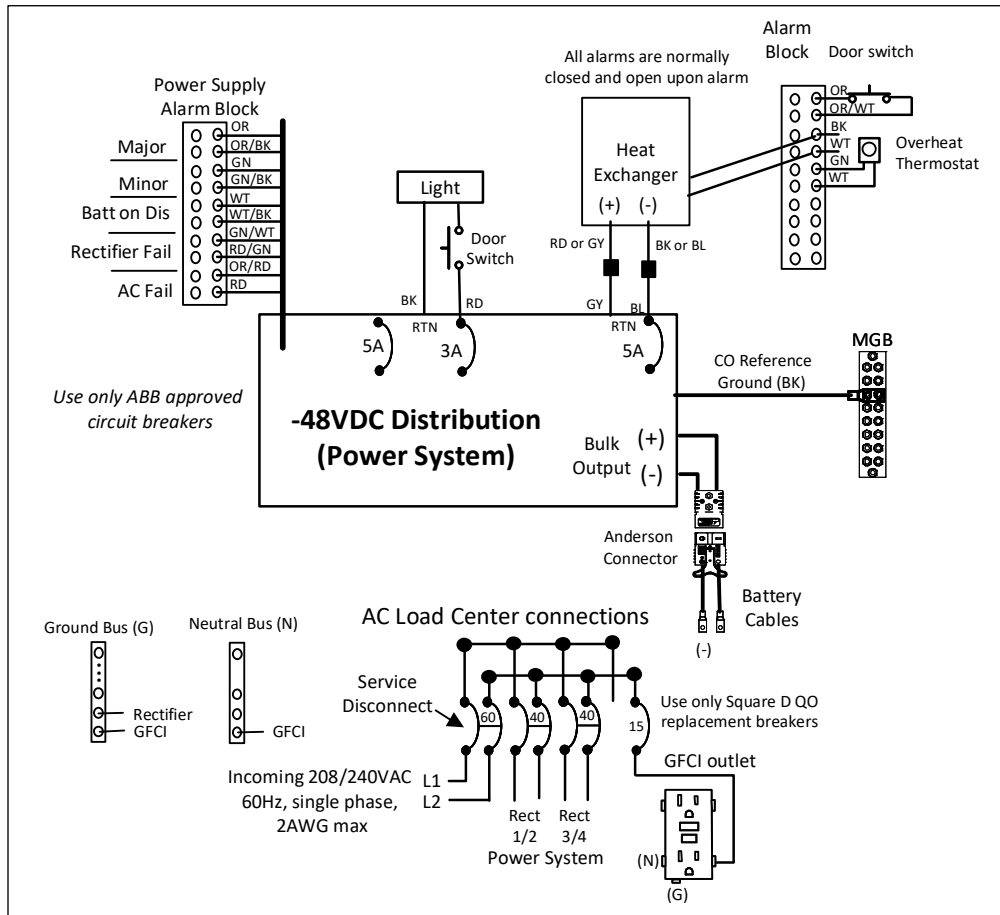

Figure 6 RL22021DB2 Electrical Diagram

3.7.1. Ground Connection

Use the 2x8 position ground bar provided in the equipment compartment for all grounding of internal equipment. Stack hardware as shown in Figure 7. External ground lugs are available on the sides of the battery compartment for connecting a site ground wire.

3.7.2. AC Voltage Connection

The incoming AC voltage is a single phase 208/240VAC at 60Hz, and is connected to the 60A service disconnect breaker on the left side of the AC load center. The maximum wire size for this breaker is 2AWG. The installer connects the two hot (line) wires to the 60A breaker, the neutral wire to the neutral bus and the ground wire to the ground bus. Use wire that is sized per National Electrical Code NFPA70 table 310.16.

The AC load center is configured as a sub panel with the separate neutral and ground busses. If the load center needs to be configured as a main panel, the green bonding screw inside the load center must be screwed down to connect the busses (refer to Figure 8).

3.7.3. -48VDC Power System

The RL22021DB2 is equipped with an ABB Infinity D power system with two 50A rectifiers, a controller, and an alarm cable. The rectifiers are controlled by two 40A breakers in the AC load center. One 3A breaker controls the LED lights, one 5A breaker controls the heat exchanger, and the other 5A breaker is available for future use.

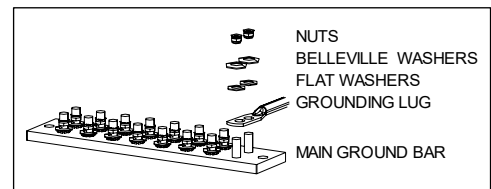

Figure 7 Ground Bar Hardware Stack

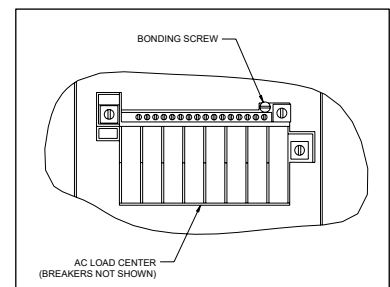

Figure 8 Bonding Screw Location

3.7.4. Battery Connection

	WARNING	<p>Always disconnect blue Anderson connectors prior to servicing batteries.</p> <p>Disregard the (+) and (-) polarity markings on the blue Anderson connectors. The cable assemblies are used on both +24VDC and -48VDC products, so markings on the Anderson connectors are misleading.</p>
---	----------------	--

Verify the polarity of the cables prior to terminating them to the batteries. Ensure the battery terminations are properly insulated to avoid shorting prior to terminating to the batteries.

1. Disconnect the Anderson connector located in the battery compartment.
2. Remove the battery retainer bracket by removing the hardware.
3. If replacing batteries, disconnect battery cables from terminals and loosen the battery retaining strap(s).
4. Remove the interconnecting straps from the batteries. Remove batteries.
5. Carefully position the new batteries on the battery tray. Connect the interconnecting straps to each battery string.
6. Connect the battery cables to the appropriate terminals.
7. Secure the battery retaining straps and reinstall the battery retainer brackets using hardware from step 2.
8. Properly manage the battery cables.
 - o Ensure that the bending radius is not less than 5x the cable diameter (e.g. 4/0 battery cable = 4 inch bend radius).
 - o Use as few bends as possible between the two termination points.
 - o Do not bend the cable at the termination points.
9. Reconnect the Anderson connector.

Notes:

- Anderson connectors terminate at the power shelf.
- NiCd batteries require nickel plated lugs. Charles cables are equipped with the correct nickel plating.
- Ensure back up battery amperage is inputted into the power system controller per power system guidelines.
- Ensure float voltage is set per power system and battery guidelines.
- Ensure all battery terminations and bus bars have No Ox applied.
- Refer to the battery manufacturer’s documentation for proper battery installation and maintenance information.

3.7.5. Heat Exchanger Operation

The 750W DC powered heat exchanger in the equipment compartment has a fan speed controller and includes an internal and an external fan. Both fans’ speed increases with increasing internal cabinet temperature. Fans and heat exchanger settings are defined below, and are based off of the cabinet interior temperature. The maximum airflow amount supplied to the equipment by the heat exchanger is 147CFM.

Setting	Internal	External
Turn-on Setting (5°C Differential)	0°C	30°C
Medium Temp Setting	30°C	35°C
High Temp Setting	45°C	50°C
High Temp Alarm Setting	70°C	N/A
Low Temp Alarm Setting	-40°C	N/A

For more information, refer to the heat exchanger documentation found inside the CUBE.

-NOTE-

Changing the speed controller default factory set points can lead to system performance issues, such as equipment failures, increased power use, unnecessary alarms, noise, condensation build up, fan failure caused by excessive runtimes and vibration. Avoid placing items in front of the heat exchanger’s return and supply vents. Maintain a minimum of 6” clearance to enable proper air flow.

3.7.6. Overheat Thermostat

The CUBE is equipped with an overheat (high temperature) alarm thermostat in the equipment compartment that provides a normally closed connection. The overheat alarm is factory set at 60°C and opens the connection if this temperature is exceeded.

-NOTE-

Changing the overheat (high-temp) thermostat default factory set points can lead to unnecessary alarms or system performance issues, such as equipment failures as a result of unreported alarms.

3.7.7. Alarm Block Connections

A 10-position, labeled alarm block monitors components in the equipment compartment. See the electrical diagram for information about alarm connections. All connections are normally closed and will open upon alarm.

3.7.8. Adjustable Rack Rails

The vertical rack rails have an adjustable depth. The unit ships with the rails 7.5" from the front and can be repositioned to a maximum of 9" by loosening the 1/4" Keps nuts on the horizontal cutouts in each rail and then re-tightening to 60 in-lbs.

3.7.9. Fiber and Copper Entry

The CUBE has three Ø1.75/2.50" knockouts on each side that accommodate Ø1.25/2.00" conduit fittings. The bottom of the battery compartment has another Ø1.75/2.50" knockout as well as two Ø1.38" knockouts that accommodate Ø1.00" conduit fittings. See Figure 2 for knockout locations.

3.8. Conduit Seals

All internal and external conduit openings on the CUBE must be completely sealed with a duct seal compound to prevent moisture from entering the equipment compartment. The battery compartment must be internally sealed from the equipment compartment to prevent outgassing from the batteries into the equipment compartment. Use a moldable, flame-retardant putty style duct seal material. Do not use an expanding foam seal. Mold the putty so that the open space around the wire or conduit is completely sealed, as shown in Figure 9. If the openings must be accessed at any time, remove the putty and set it aside. When work is complete, re-mold the putty to re-seal the opening.

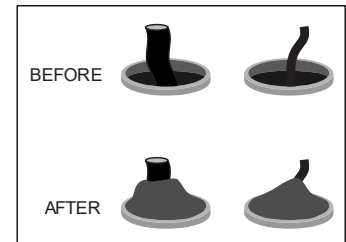

Figure 9 Applying Putty Seal

3.9. Verifying the Installation

Verify that earth ground and all grounding and bonding is complete and functional. After verifying that all installer connections are secure and complete, apply voltage.

4. PERIODIC MAINTENANCE

In the event that the enclosure needs to be opened in freezing conditions, a narrow, pointed metallic object such as a screwdriver or chisel, along with a non-metallic device like a rubber mallet, may be used to remove excessive ice buildup around the door and locking mechanism. A commercial aerosol de-icer spray can be used to free up locks and latches if needed.

Periodic cleaning of the battery filter screens is important to maintain proper ventilation. To clean the filter screens, remove the four nuts on each screen and take out the screens. Use a soft brush or hose to remove any debris from the screen. Once clean, replace the screens using the four nuts removed previously.

Reset the GFCI duplex receptacle periodically to ensure it is working. The unit meets UL-943, which requires an auto-monitoring (self-testing) feature. A flashing or solid red LED indicates a fault. If the unit continues to show a fault after resetting, replace the unit.

The heat exchanger requires no scheduled maintenance other than cleaning the fans and heat exchanger core if they become contaminated with dust or residue. Remove the cover by removing the screws on the outside. Examine periodically to determine the required cleaning periods based on the installed environmental conditions.

5. TECHNICAL ASSISTANCE AND REPAIR SERVICE

For questions on product repair or if technical assistance is required, contact Charles Technical Support.

847-806-8500

techserv@charlesindustries.com (email)

<http://www.charlesindustries.com/techserv.htm>

6. WARRANTY & CUSTOMER SERVICE

Charles Industries LLC offers a one-year warranty on the CUBE product. The Charles warranty is limited to the operation of the CUBE hardware as described in this documentation and does not cover equipment which may be integrated by a third party. The terms and conditions applicable to any specific sale of product shall be defined in the resulting sales contract. For questions on warranty or other customer service assistance, contact your Charles Customer Service Representative.

847-806-6300

mktserv@charlesindustries.com (email)

http://www.charlesindustries.com/main/telecom_sales_support.htm

7. SPECIFICATIONS

7.1. Regulatory Specifications

- Designed to meet GR-487
- GFCI: UL-943 Listed

If CUBEs are field-modified, a customer provided ETL field evaluation of the modified components may be required to re-establish ETL certification to UL standards. Consult local jurisdictions for guidance on a site-by-site basis.

7.2. Product Specifications

Physical	
Dimensions	54"Hx26"Wx20"D
Weight	RL22021DB1: Approx. 155 lbs. as shipped RL22021DB2: Approx. 215 lbs. as shipped
19" Equipment Rack Space and Hole Spacing	35" (20RU) EIA spacing with tapped #12-24 mounting holes
Battery Tray Size	20.875"Wx15.787"Dx13"H
Maximum Supported Weight	Rack Rails: 220 lbs. Battery Tray: 400 lbs.
Materials	0.125" aluminum
Color	Off-white
Electrical	
Power System	48VDC, ABB CC109161320
Rectifiers	48VDC, ABB CC109158878
AC Load Center	Square 8, QO816L100RB
Supported Batteries	Saft Tel.X 80 (80-94690-02) or Saft Tel.X 100 (80-94692-02)
Bonding and Grounding	One 2x8 position ground bar in equipment compartment, 2 external grounds
Cable Entry	See Figure 2 or section 3.7.9
Thermal	
Heat Exchanger	750W, 48VDC, Vikinor VHC-040-DC
Maximum Heat Dissipation	700W@19°C above ambient with solar
Environmental	
Operating Temp. Range, Outside Enclosure	-40° to +115°F, -40° to 46°C
Operating Temp Range, Inside Enclosure	-40° to +149°F, -40° to 65°C
Humidity	0 to 95% (non-condensing)
Altitude	Up to 2,000 meters (6560 feet)
Kits and Replacement Parts	
Touch-up Paint	02-000290-0
216 Type Security Tool	07-002070-0
H-Frame Mounting Kit	97-001971-A
Plinth Mounting Kit	97-002176-A
Pole Mounting Kit	97-CABPMTKIT
Swing Handle	39-000148-0
4-Wire Door Alarm Switch (Black)	17-400319-0
15A GFCI Outlet	04-100207-0
Overheat Thermostat	99-004548-0

Table 1 CUBE Specifications