

# Charles Universal Broadband Enclosure

## CUBE-PM64015IN1 and CUBE-PM640150N1

### General Description and Installation

<b>1. GENERAL INTRODUCTION .....</b>	<b>1</b>
1.1. Document Purpose .....	1
1.2. Product Purpose .....	1
1.3. Product Mounting and Location .....	1
<b>2. PRODUCT DESCRIPTION .....</b>	<b>2</b>
<b>3. INSTALLATION .....</b>	<b>5</b>
3.1. Inspecting the Product .....	5
3.2. Following and Using Safety Precautions .....	5
3.3. Obtaining Tools and Equipment .....	5
3.4. Preparing the Installation Site .....	5
3.5. Lifting the CUBE .....	6
3.6. Mounting the CUBE .....	6
3.7. CUBE Wiring and Equipment .....	7
3.8. Conduit Seals .....	10
3.9. Verifying the Installation .....	10
<b>4. PERIODIC MAINTENANCE .....</b>	<b>10</b>
<b>5. TECHNICAL ASSISTANCE AND REPAIR SERVICE .....</b>	<b>10</b>
<b>6. WARRANTY &amp; CUSTOMER SERVICE .....</b>	<b>10</b>
<b>7. SPECIFICATIONS .....</b>	<b>11</b>
7.1. Regulatory Specifications .....	11
7.2. Product Specifications .....	11

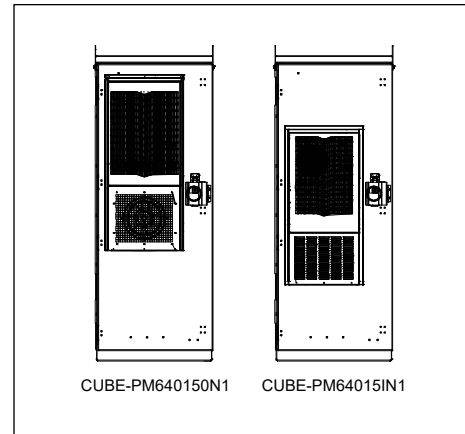

**Figure 1 Front View of the CUBE**

## 1. GENERAL INTRODUCTION

### 1.1. Document Purpose

This document provides general information for the CUBE-PM64015IN1 and CUBE-PM640150N1 of the Charles Industries’ Universal Broadband Enclosure (CUBE) product line. Figure 1 shows a closed front view of the enclosure.

-NOTE-

*Hereafter, the Charles Universal Broadband Enclosure CUBE-PM64015IN1 and CUBE-PM640150N1 will be referred to by individual part number or collectively as the “CUBE.”*

### 1.2. Product Purpose

The CUBE consists of a protective enclosure for an integrated system of electronic components and equipment that can serve fiber and copper interfaces.

### 1.3. Product Mounting and Location

This enclosure is suitable for outside plant-type (OSP) locations and those that may require NEC compliance. The outdoor, weather-resistant CUBE is to be mounted on a steel grate platform. It can also be mounted on a wall or concrete pad using the appropriate mounting kit (see section 3.6). The installer connects the power, fiber and copper connections. Detailed mounting and installation information is covered in Section 3.

## 2. PRODUCT DESCRIPTION

The CUBE is a single equipment compartment with 40RU of 23" horizontal rack mount spacing and a slack storage tray for use in routing cables and fibers. The PM64015IN1 has a 6000BTU HVAC system, while the PM640150N1 has a 3500W heat exchanger.

Figure 2 shows the CUBE dimensions. Figures 3 and 4 show the main components of each CUBE.

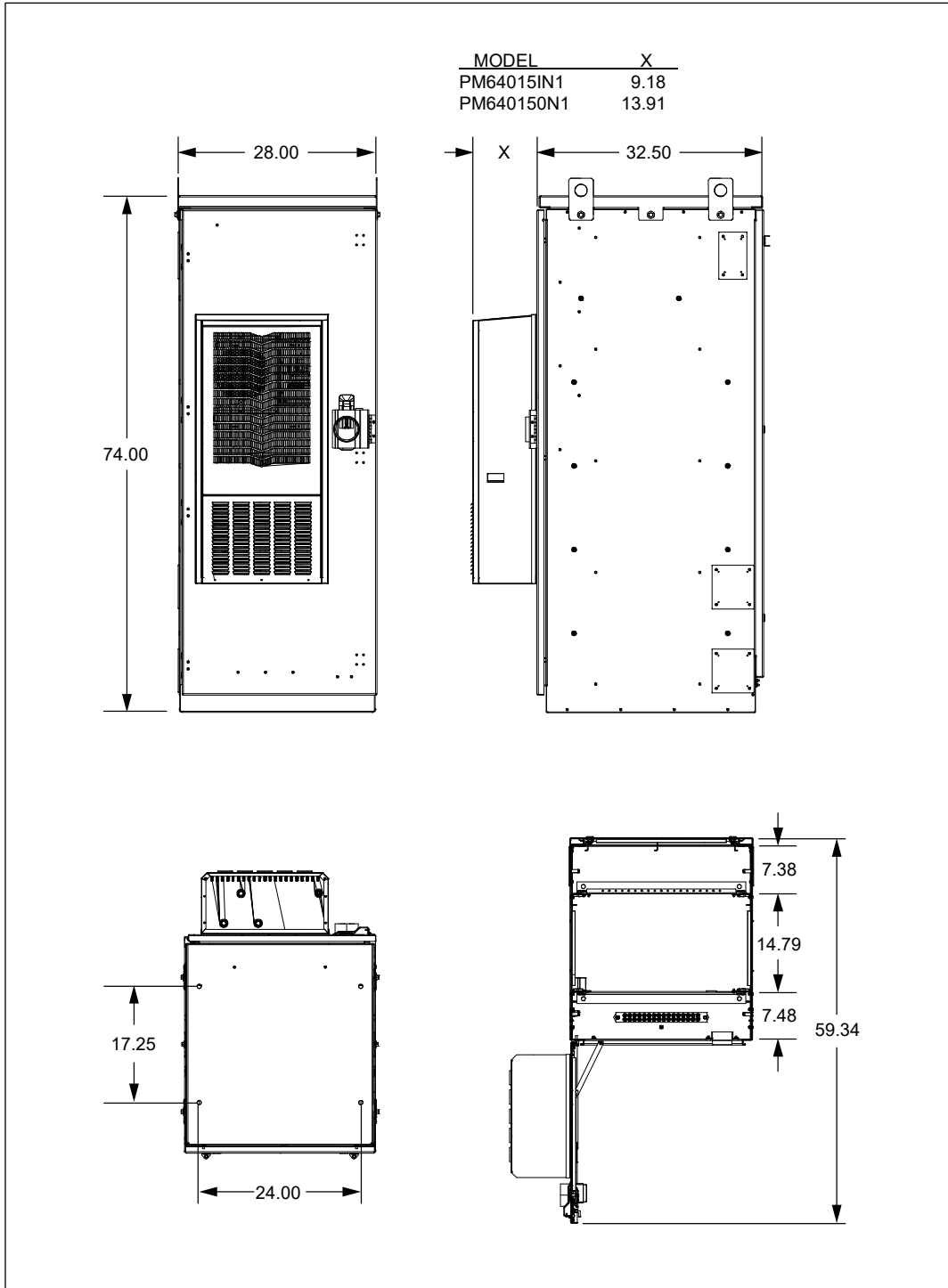

**Figure 2 CUBE Dimensions (in inches)**  
 All dimensions are common to all models except for depth of thermal unit.

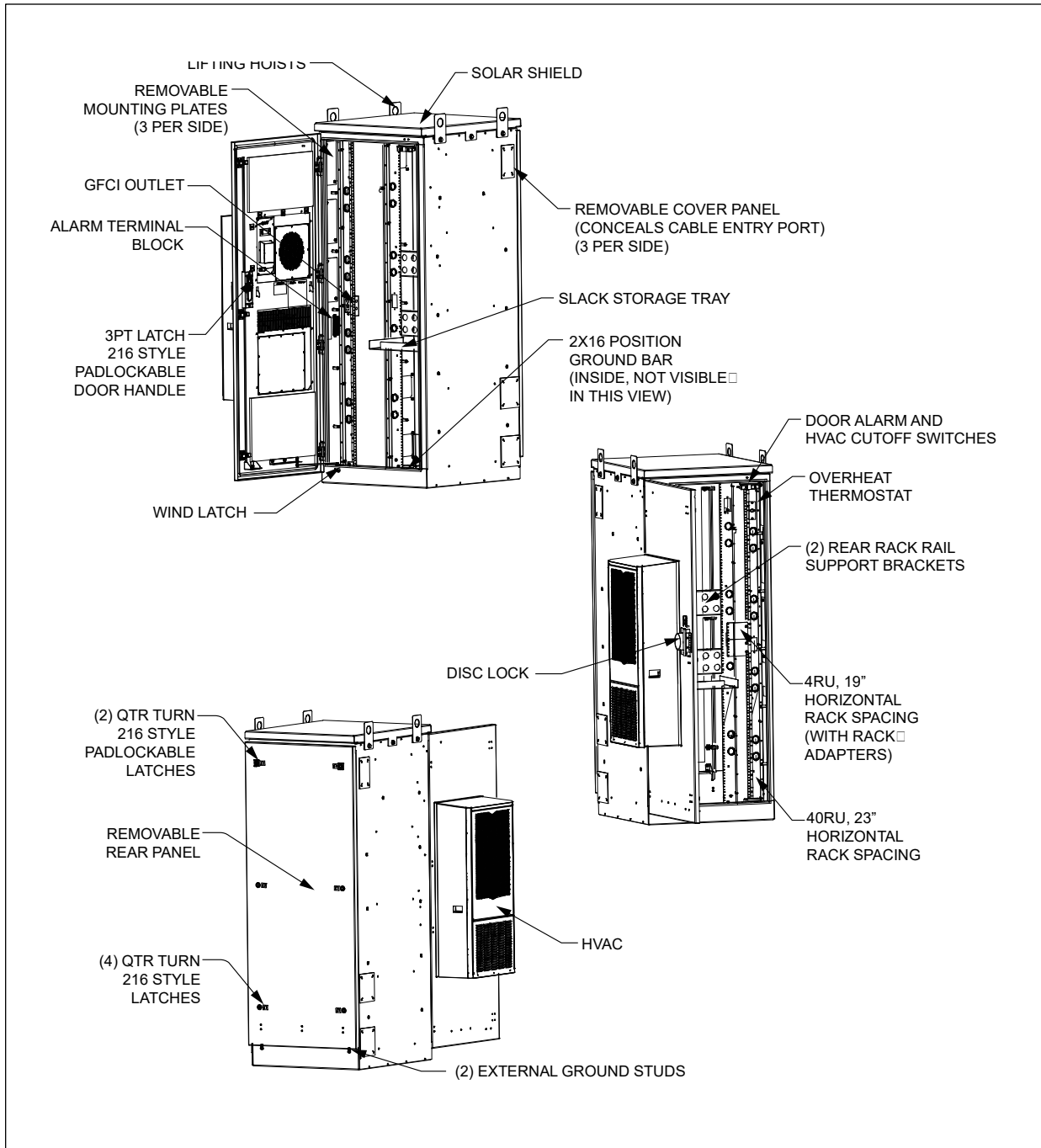

**Figure 3 PM64015IN1 Components**

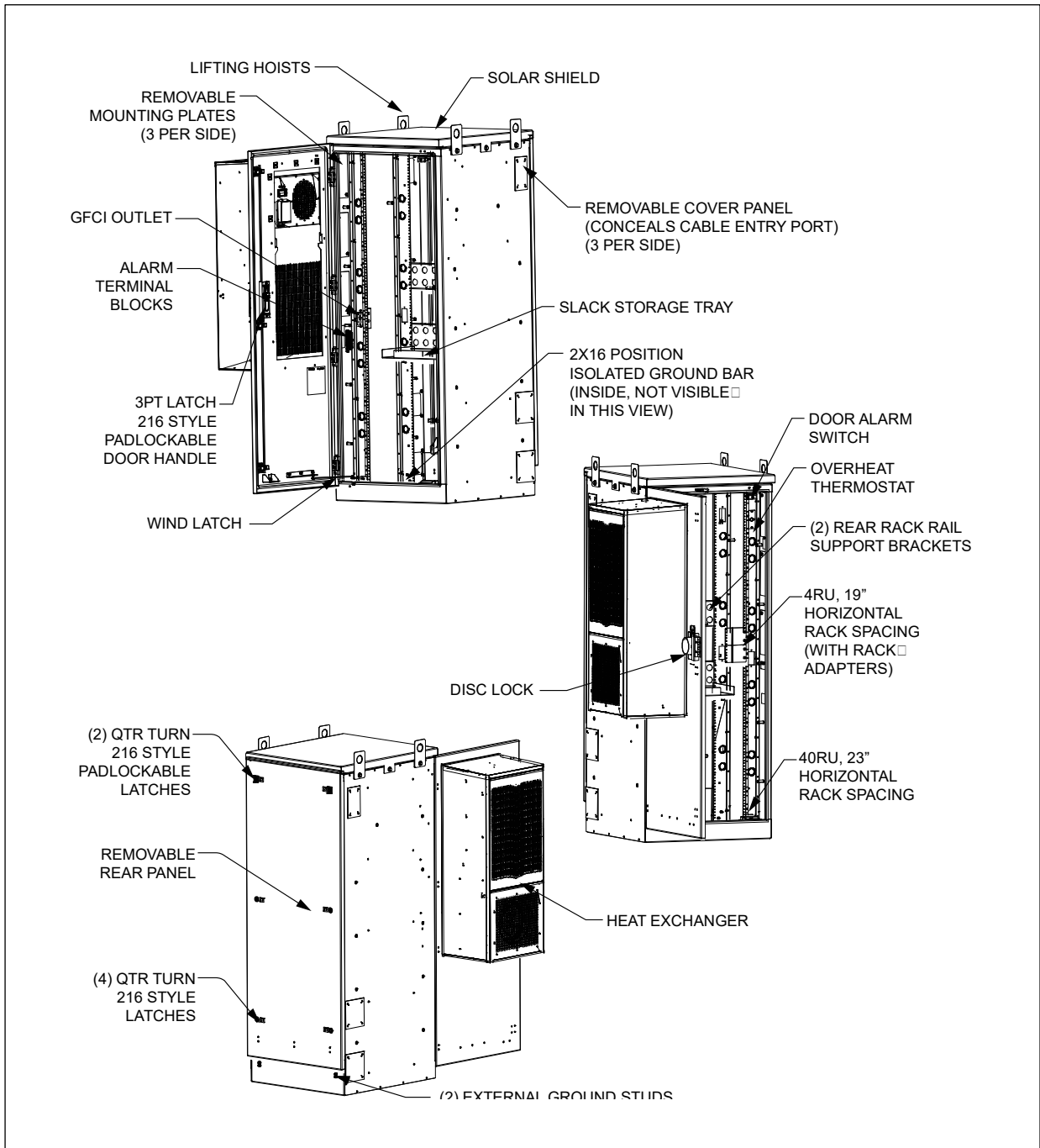

Figure 4 PM640150N1 Components

### 3. INSTALLATION

#### 3.1. Inspecting the Product

The CUBE is shipped mounted upright on a skid. Remove the bolts, unpack the unit, and dispose of the packaging material.

*-INSPECTION NOTE-*

*Visually inspect the unit for damages prior to installation. If the equipment was damaged in transit, immediately report the extent of the damage to the transportation company.*

#### 3.2. Following and Using Safety Precautions

Read the following site and safety tips, cautions, and warnings, then proceed with the paragraphs that follow.

- For installation, follow all National Electrical Codes (NEC) ANSI/NFPA 70, local, environmental, workplace, and company codes, safety procedures, and practices.
- Minimum spacing between the accessories and components and the housing for ITE equipment shall be maintained for safe operation of the equipment when installed in accordance with NEC ANSI/NFPA 70.
- Read all instructions, warnings and cautions on the equipment and in the documentation shipped with the product.
- Always connect ground connections first.
- Do not place this product on weak or unstable surfaces which may allow the product to fall, resulting in potentially serious damage(s) to persons or product.
- Only authorized trained personnel shall install the CUBE.
- In windy conditions, be sure to engage the door latches to secure the door in a stationary position.

#### 3.3. Obtaining Tools and Equipment

Obtain the following recommended or needed items for installing the CUBE.

- Sufficient length and quantities of fiber cable (or pigtails)
- Cable scoring, opening, and cutting tools for cable sheathing, shields, wrappings, strength members, and buffer tubes
- Wire strippers
- Crimpers
- Cable, tube, wire, and fiber cleaning materials
- Protective and/or insulated work gloves
- Safety glasses
- Tape measure
- Marking utensil
- #6 ground wire or rod and earth ground materials
- Bond strap (optional, from cable bond clamp to bond post)
- Any exterior cable strain relief, per company practice
- Slotted, hex, and Phillips screwdrivers
- Torque wrench
- Assorted cable ties, clips, or fasteners (optional)
- Can wrench (216 type tool)
- Torque wrench
- Derrick for lifting
- Level

#### 3.4. Preparing the Installation Site

Observe the following site preparation recommendations.

- Leave adequate horizontal and vertical space between multiple installations to allow for proper cable access, as well as enough room around the enclosure to open the door(s).
- The site must meet minimal personnel and equipment safety requirements.
- The distance from the cable entry point should be consistent with local installation practices.
- The concrete pad must be able to support the weight of the CUBE.
- Run all fiber and copper facilities to the site.

### 3.5. Lifting the CUBE

See Table 1 for CUBE weight. Charles recommends the following procedure for lifting the CUBE.

	<b>WARNING</b>	<b>Prior to lifting, remove the lifting brackets that hold the mounting gasket in place. Set aside the gasket, and then replace the brackets. Failure to do so can result in a failure of the lifting bracket assembly.</b>
--	----------------	---

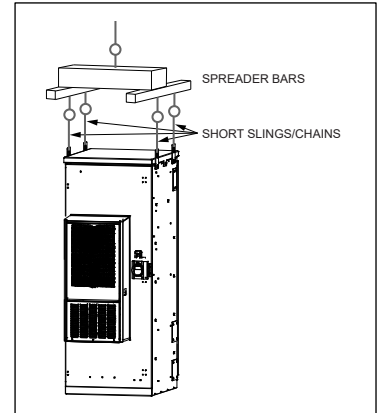

Figure 5 Lifting the CUBE

#### 3.5.1. Required Equipment

- One derrick (crane) capable of lifting the CUBE
- Spreader bars
- Four lifting slings or chains with each having a 2,500 lbs. capacity
- Connecting links to attach slings to the CUBE's lifting brackets
- 75-ft. long tagline rope

Insert the lifting sling connecting links securely through each of the lifting brackets as shown in Figure 5.

#### 3.5.2. Warnings and Specific Safety Precautions

	<b>WARNING</b>	<b>Improper hoisting equipment and unsafe lifting procedures can result in serious injury or death</b>
--	----------------	--

Observe the following local safety procedures when performing the tasks in this section.

- Keep the CUBE away from any power lines.
- Keep bystanders away from the work operations at all times.
- Only trained operators shall operate the crane for lifting and setting the CUBE.
- Do not suspend loads over people or equipment.
- All persons working with hoisting equipment shall wear standard safety gear according to local practices including safety helmets and steel-toed shoes.
- Do not operate the hoisting equipment until all stabilizer are extended and in firm contact with the ground or adequate support structure.
- Do not attempt to retract or extend the stabilizers while a load is suspended.

### 3.6. Mounting the CUBE

#### 3.6.1. Mounting the CUBE on a Steel Grate Platform

To secure the CUBE to a steel grate platform, install 1/2" corrosion-resistant Grade 5 steel hardware through the cabinet and platform grate. Ensure that the bolts are long enough to extend past the nut on the bottom side of the platform grate. For all mounting applications, each bolted joint should have a minimum Ø1 inch fender washer on the inside of the cabinet and underside of the platform grate with a lock washer. The washer on the underside of the platform must be large enough to cover both adjacent bearing bars as shown in Figure 6.

#### 3.6.2. Lacing Bar

A lacing bar ships loose with the CUBE. This lacing bar is intended for mounting on the rack rails at any location that supports the equipment installed in the cabinet. Use customer supplied #12-24 screws.

#### 3.6.3. Torque Requirements

Torque all hardware as shown below (unless otherwise noted). These values apply to SAE Grade 1 & 2 Low Carbon Steel, ASTM A307 Low Carbon Steel, and Stainless Steel Grade 18-8.

Thread Size	In-lbs	Ft-lbs
4-40	4±10%	
6-32	8±10%	
8-32	16±10%	
10-32	26±10%	
12-24	50±10%	
1/4-20/M6	60±5%	5±5%
5/16-18	125±5%	10.4±5%
3/8-16	180±5%	15.0±5%
1/2-13	500±2%	41.7±2%
5/8-11	1000±1%	83.3±1%

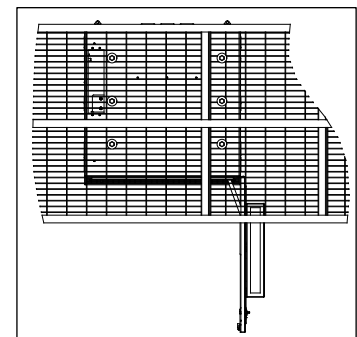

Figure 6 Installing on a Platform

### 3.7. CUBE Wiring and Equipment

After the CUBE is properly mounted in the desired location, apply No-Ox where bus bar and other 2-hole lug connections will be made. Install ground and power connections. Always ground the equipment first, before making any other connections.

	<b>WARNING</b>	<b>Perform all bonding and grounding connections prior to any electrical and communications connections.</b>
--	----------------	--

In order to prevent condensation prior to being placed in service, do not remove the desiccant until the CUBE is sealed and power is applied. Basic electrical diagrams are shown in Figures 7 and 8.

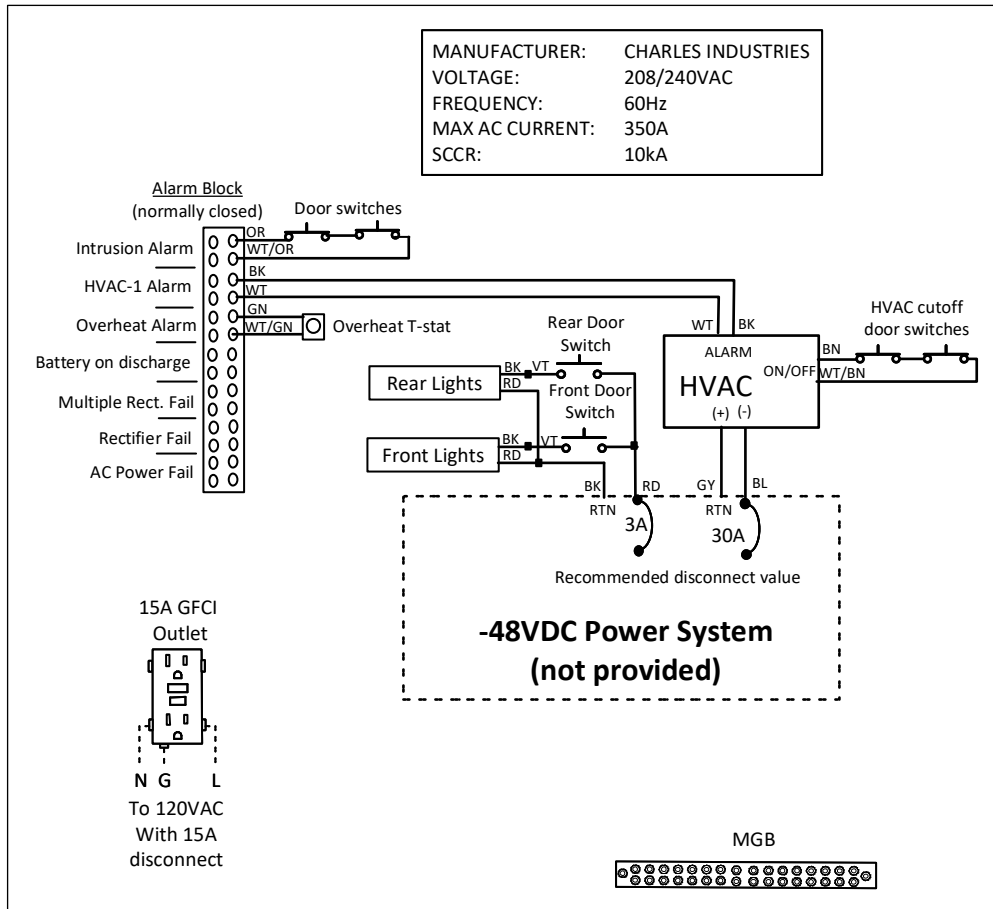

**Figure 7 PM64015IN1 Electrical Diagram**

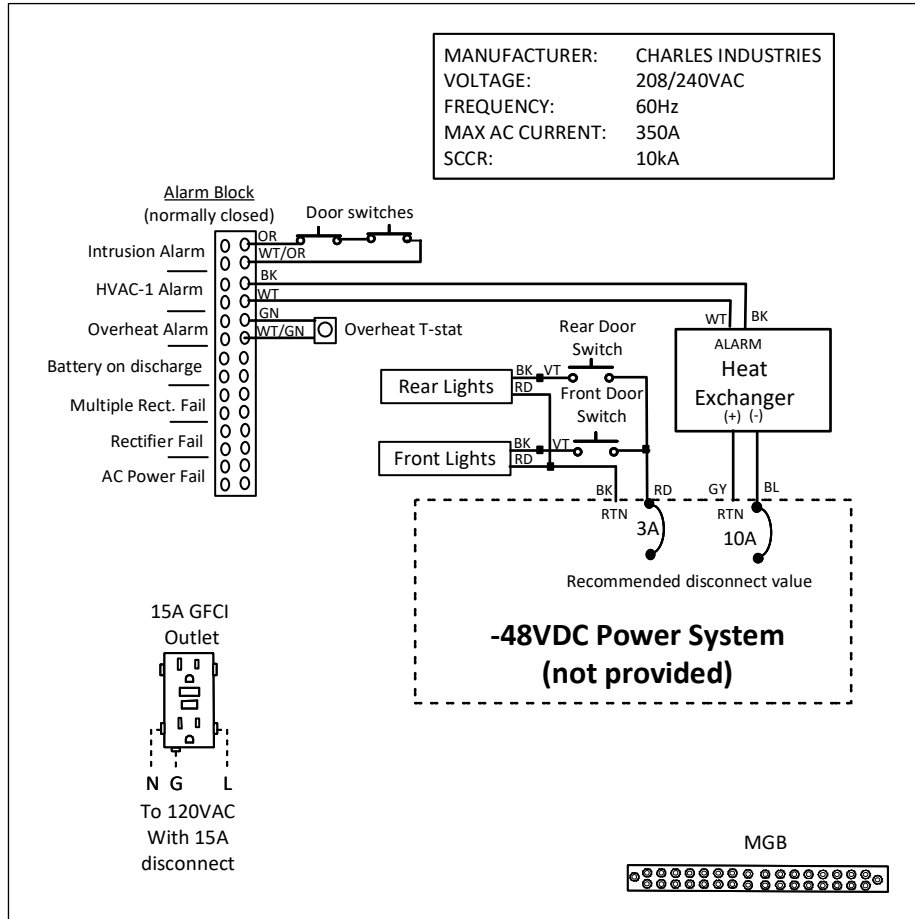

**Figure 8 PM640150N1 Electrical Diagram**

**3.7.1. Ground Connection**

Use the 2x8 position ground bar provided in the equipment compartment for all grounding of internal equipment. Stack hardware as shown in Figure 9. External ground points are available on the sides and rear for connecting a site ground wire.

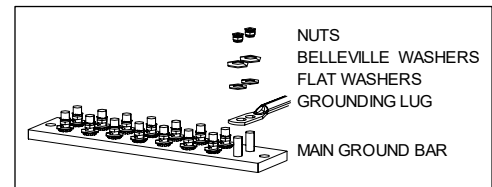

**Figure 9 Ground Bar Hardware Stack**



**3.7.2. HVAC Operation (PM64015IN1 Only)**

The 6000BTU DC-powered HVAC compressor and fans are PID (proportional integral derivative) controlled. The compressor turns on at 33°C at low speed and will increase/decrease speed as needed to maintain this temperature. The compressor turns off when the internal temperature reaches 28°C. The internal fan is always on at low speed (30%) to continually circulate heat within the cabinet. The external fan turns on/off with the compressor. Both fans’ speed increase as needed with increasing internal cabinet temperature. In addition, the HVAC includes a built-in 500W heater for cold temperature operation. HVAC settings for the compressor, fans, heater, and temperature alarms are defined below and are based off the cabinet’s interior temperature. The CUBE is equipped with a cutoff switch that shuts off the HVAC compressor when a door is opened to minimize condensation buildup on the coils. The maximum airflow amount supplied to the equipment by the HVAC is 441CFM.

HVAC Compressor/Fans/Heater/Alarms Setting	Internal	External
Compressor Turn-on Setting	33°C	N/A
Compressor Turn-off Setting	28°C	N/A
Fan Turn-on Setting	-40°C	33°C
Heater ON Setting (50% Fan Speed)	8°C	N/A
Heater OFF Setting	13°C	N/A
High Temp Alarm Setting	65°C	N/A
Low Temp Alarm Setting	0°C	N/A

For further information, refer to the HVAC documentation that ships with the CUBE.

-NOTE-

*Changing the cooling or heating cycles’ default factory set points can lead to system performance issues, such as equipment failures, increased power use, unnecessary alarms, noise, condensation build up, compressor or fan failure caused by excessive runtimes and vibration.*

*Avoid placing items in front of the HVAC’s return and supply vents. Maintain a minimum of 4” clearance to enable proper airflow.*

**3.7.3. Heat Exchanger Operation (PM640150N1 Only)**

The 3400W DC powered heat exchanger (thermosiphon) in the equipment compartment has a fan speed controller and includes an internal and an external fan. Both fans’ speed increases linearly from 30% to 100% with increasing internal cabinet temperature. In addition, the heat exchanger includes a built-in 500W heater for cold temperature operation. Settings for fans, heater, and temperature alarms are defined below and are based off the cabinet’s interior temperature. The maximum airflow amount supplied to the equipment by the heat exchanger is 530CFM.

Fans/Heater/Alarms Setting	Internal	External
Fan Turn-on Setting (30% Speed)	-40°C	30°C
Fan Ramp-up Start Temp Setting	35°C	35°C
Fan High Speed Temp Setting	45°C	45°C
Heater ON Setting (70% Fan Speed)	7°C	N/A
Heater OFF Setting	10°C	N/A
High Temp Alarm Setting	65°C	N/A
Low Temp Alarm Setting	0°C	N/A

For more information, refer to the heat exchanger documentation found inside the CUBE.

-NOTE-

*Changing the speed controller default factory set points can lead to system performance issues, such as equipment failures, increased power use, unnecessary alarms, noise, condensation build up, fan failure caused by excessive runtimes and vibration.*

*Avoid placing items in front of the heat exchanger’s return and supply vents. Maintain a minimum of 4” clearance to enable proper airflow.*

**3.7.4. Alarm Block Connections**

A 16-position, labeled alarm block monitors the components in the equipment compartment. See the electrical diagram for information about alarm connections. All connections are normally closed and will open upon alarm.

### 3.7.5. Slack Storage Tray

The slack storage tray is mounted in the rack rail. For convenience, the tray can be removed from the rack rail prior to coiling slack.

Note: The total storage capacity of the tray is 147 feet of fiber cable with a 3mm diameter.

1. Create a fiber service loop by pulling the fiber from the rack rails toward the tray.
2. Coil the fiber slack inside the tray through one of the openings in the rear of the tray. Wind the fiber around the bend controls, observing the proper bend radius. Fiber exits through the second opening on the rear (Figure 10).

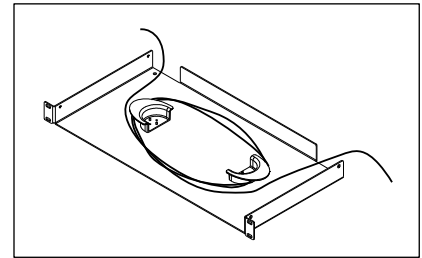

Figure 10 Fiber Routing

### 3.7.6. Fiber and Copper Entry

The CUBE has knockouts on both sides that accommodate conduit fittings. See Figure 2 for knockout locations.

- Ø1.25” knockouts accommodate Ø1.00” fittings.
- Ø1.50” knockouts accommodate Ø1.15” fittings
- Ø1.75” knockouts accommodate Ø1.25” fittings.
- Ø2.50” knockouts accommodate Ø2.00” fittings.

### 3.8. Conduit Seals

All conduit openings on the CUBE must be completely sealed with a duct seal compound to prevent moisture from entering the CUBE. Use a moldable, flame-retardant putty style duct seal material. Do not use an expanding foam seal. Mold the putty so that the open space around the wire or conduit is completely sealed, as shown in Figure 11. If the openings must be accessed at any time, remove the putty and set it aside. When work is complete, re-mold the putty to re-seal the opening.

### 3.9. Verifying the Installation

Verify that earth ground and all grounding and bonding is complete and functional. After verifying that all installer connections are secure and complete, apply voltage.

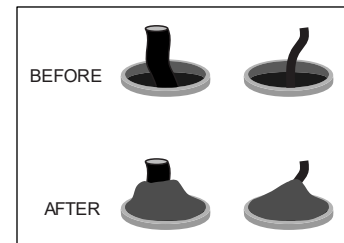

Figure 11 Applying Putty Seal

## 4. PERIODIC MAINTENANCE

In the event that the enclosure must be opened in freezing conditions, use a narrow, pointed metallic object such as a screwdriver or chisel, along with a non-metallic device like a rubber mallet, to remove excessive ice buildup around the door and locking mechanism. A commercial aerosol de-icer spray can be used to free up locks and latches if needed. Use protective gloves and safety glasses when applying de-icer sprays.

Reset the GFCI duplex receptacle periodically to ensure it is working. The unit meets UL-943, which requires an auto-monitoring (self-testing) feature. A flashing or solid red LED indicates a fault. If the unit continues to show a fault after resetting, replace the unit.

Refer to the HVAC or HX manual supplied with the CUBE for periodic maintenance requirements.

## 5. TECHNICAL ASSISTANCE AND REPAIR SERVICE

For questions on product repair or if technical assistance is required, contact Charles Technical Support.

847-806-8500  
[techserv@charlesindustries.com](mailto:techserv@charlesindustries.com) (email)  
<http://www.charlesindustries.com/techserv.htm>

## 6. WARRANTY & CUSTOMER SERVICE

Charles Industries LLC offers a one-year warranty on the CUBE product. The Charles warranty is limited to the operation of the CUBE hardware as described in this documentation and does not cover equipment which may be integrated by a third party. The terms and conditions applicable to any specific sale of product shall be defined in the resulting sales contract. For questions on warranty or other customer service assistance, contact your Charles Customer Service Representative.

847-806-6300  
[mktserv@charlesindustries.com](mailto:mktserv@charlesindustries.com) (email)  
[http://www.charlesindustries.com/main/telecom\\_sales\\_support.htm](http://www.charlesindustries.com/main/telecom_sales_support.htm)

## 7. SPECIFICATIONS

### 7.1. Regulatory Specifications

- Designed to meet GR-487
- GFCI: UL-943 Listed

If CUBE's are field-modified, a customer provided ETL field evaluation of the modified components may be required to re-establish ETL certification to UL standards. Consult local jurisdictions for guidance on a site-by-site basis.

### 7.2. Product Specifications

<b>Physical</b>	
Dimensions	74"Hx28"Wx32"D
Weight	PM64015IN1: Approx. 346 lbs. as shipped PM640150N1: Approx. 355 lbs. as shipped
23" Equipment Rack Space and Hole Spacing	70" (40RU) rack spacing with tapped EIA #12-24 mounting holes
Materials	0.1" aluminum
Color	Off-white
<b>Electrical</b>	
Bonding and Grounding	Two 2x8 position ground bars inside CUBE External grounding points on rear and both sides
Cable Entry	See Figure 2 and section 3.7.9
<b>Thermal</b>	
PM64015IN1	
HVAC	1800W, 48VDC, Vikinor VAK-1800-DC
Cooling Capacity	6000BTU
PM640150Nx	
Heat Exchanger	1800W, 48VDC, Vikinor VHT-180-DC
Cooling Capacity at Full Speed	180W/K
Heating Capacity	500W
<b>Environmental</b>	
Operating Temp. Range, Outside Enclosure	-40° to +115°F, -40° to 46°C
Operating Temp Range, Inside Enclosure	-40° to +149°F, -40° to 65°C
Humidity	0 to 95% (non-condensing)
Altitude	Up to 2,000 meters (6560 feet)
<b>Kits and Replacement Parts</b>	
Touch-up Paint	02-000290-0
216 Type Security Tool	07-002070-0
Lift-Up Handle	39-000335-0
Latch	39-200949-0
1/4 Turn Latch	39-300163-0
1/4 Turn Latch with Padlock Hasp	39-000449-0
4-Wire Door Alarm Switch (Black)	17-400329-0
HVAC Cutoff Switch (Black with White Button)	17-400322-0
15A GFCI Outlet	04-100207-0
Overheat Thermostat	99-005205-0
Front to Back Rail Equipment Support Bracket Kit	97-003010-A
Rear Rail Equipment Support Bracket Kit	97-002424-A
Rear, Angled Equipment Support Bracket	97-002428-A
19-23" Rack Extender Kit, 2 RU, Left and Right	97-RACKEXT2RU
19-23" Rack Extender Kit, 4 RU, Left and Right	97-RACKEXT4RU
100AH Polarium Battery Rear Mounting Kit	97-002429-A
200AH Polarium Battery Rear Mounting Kit	97-002430-A
Enhanced Rail Support System	97-002433-A

Table 1 CUBE Specifications