

Charles Outdoor Hub Cabinet

OHC-864

General Description and Installation

1. GENERAL INTRODUCTION	1
1.1. Document Purpose	1
1.2. Product Purpose	1
1.3. Product Mounting and Location	1
2. PRODUCT DESCRIPTION.....	2
3. INSTALLATION	4
3.1. Inspecting the Product	4
3.2. Following and Using Safety Precautions.....	4
3.3. Obtaining Tools and Equipment	4
3.4. Preparing the Installation Site.....	4
3.5. Lifting the OHC.....	5
3.6. Mounting the OHC	5
4. FIBER ROUTING.....	7
4.1. Splitter Side	7
4.2. Feed Cable	8
4.3. Distribution Cable	8
4.4. Conduit Seals.....	10
5. PERIODIC MAINTENANCE.....	10
6. TECHNICAL ASSISTANCE AND REPAIR SERVICE	10
7. WARRANTY & CUSTOMER SERVICE	10
8. SPECIFICATIONS.....	10

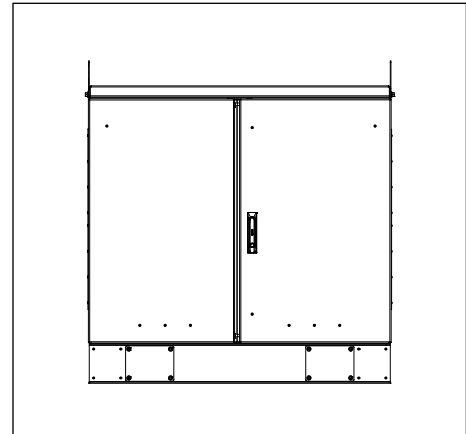

Figure 1 Front View of the OHC

1. GENERAL INTRODUCTION

1.1. Document Purpose

This document provides general information for the OHC-864 of the Charles Industries’ Outdoor Hub Cabinet (OHC) product line. Figure 1 shows a closed front view of the enclosure.

-NOTE-
Hereafter, the Charles Outdoor Hub Cabinet OHC-864 will be referred to as the “OHC.”

1.2. Product Purpose

This OHC is a connection hub for fiber splitting operations.

1.3. Product Mounting and Location

This enclosure is suitable for outside plant-type (OSP) locations and those that may require NEC compliance. The outdoor, weather-resistant OHC is to be mounted on a pad. Detailed mounting and installation information is covered in Section 3.

2. PRODUCT DESCRIPTION

The OHC cabinet has front and rear sides. The front side is for routing splitter connections, and the rear is for routing feed and distribution fiber.

Figure 2 shows the OHC dimensions. Figure 3 shows the main components of the OHC.

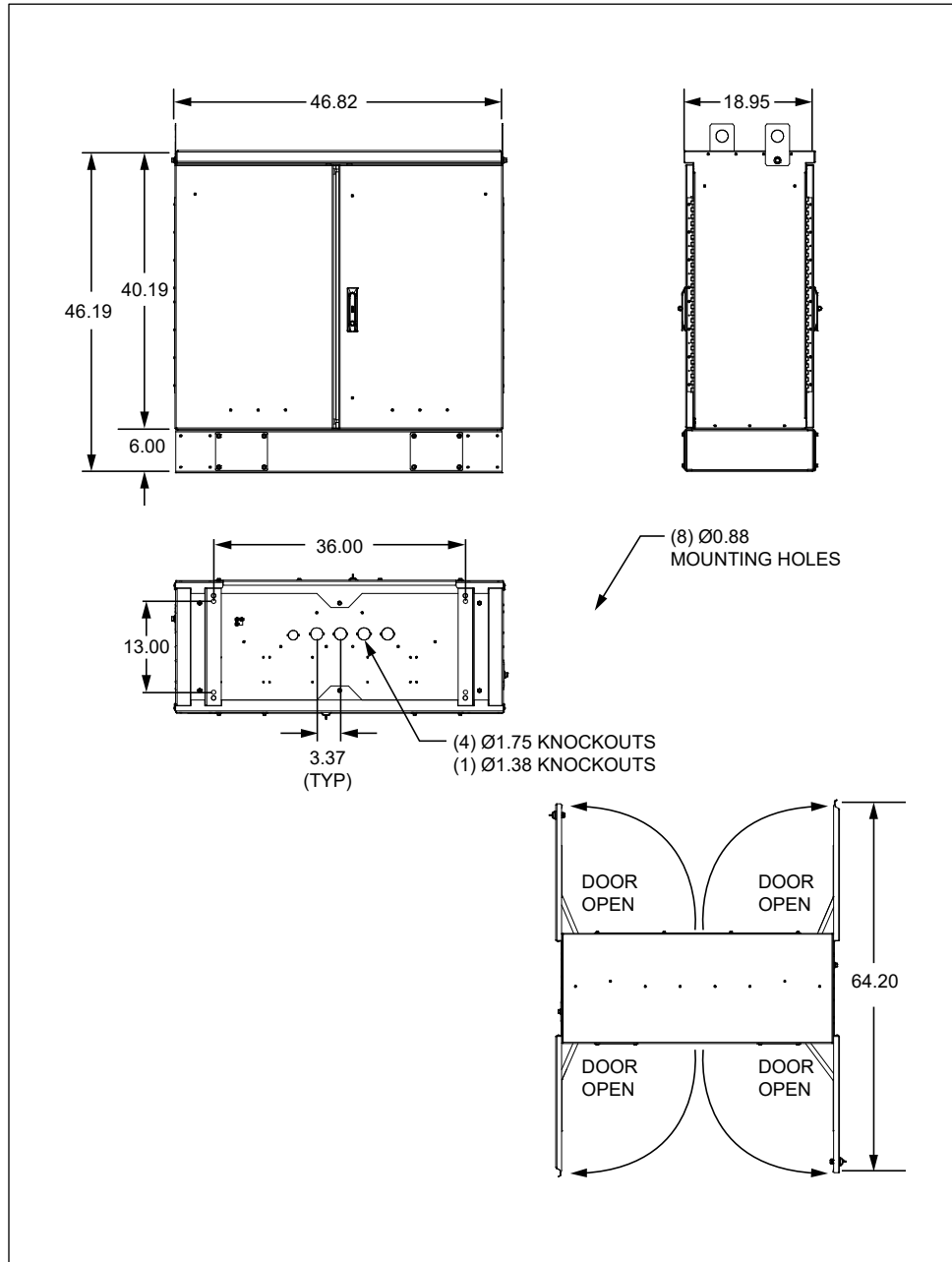

Figure 2 OHC Dimensions (in inches)

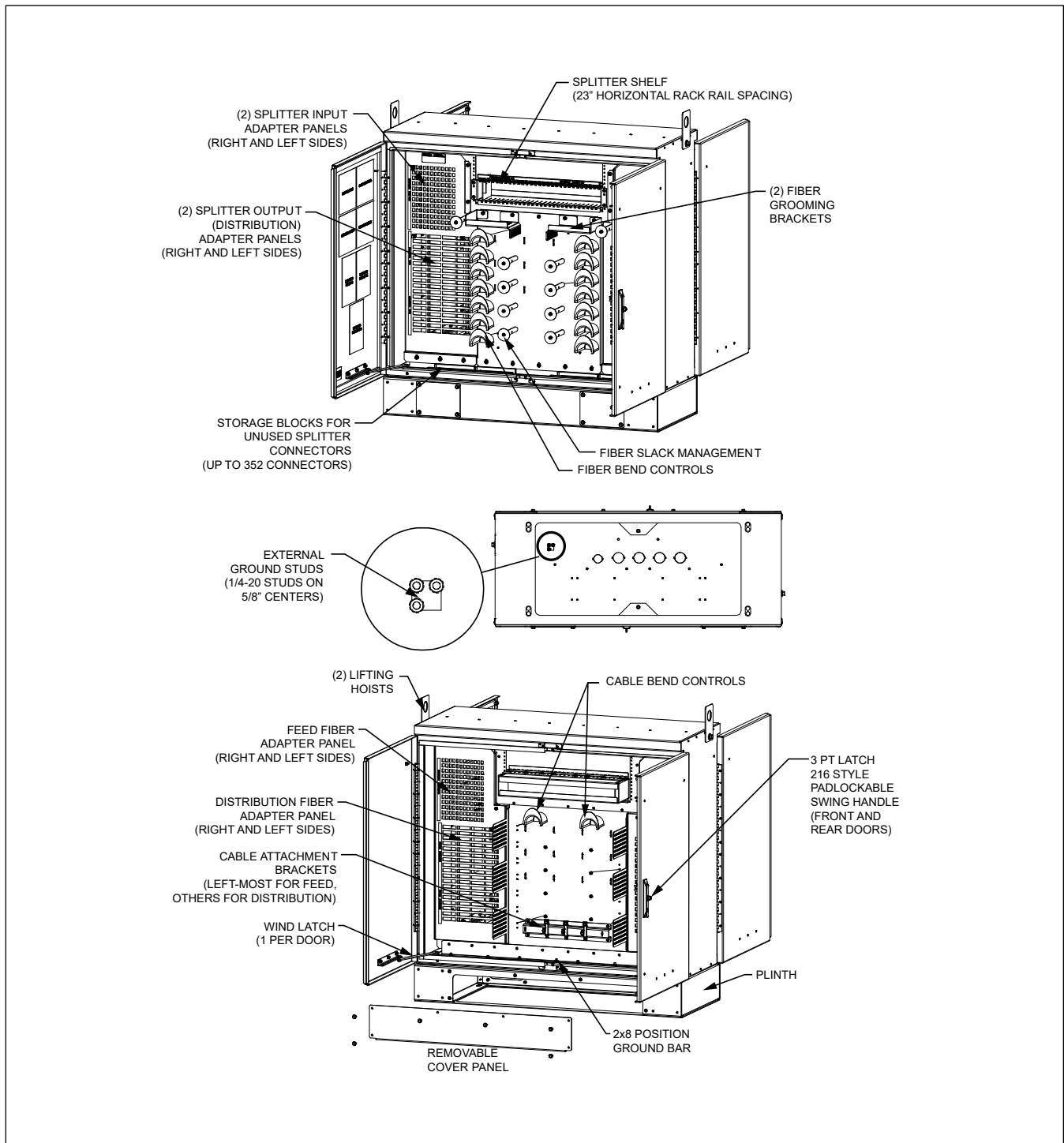

Figure 3 OHC Components
Top View: Front (Splitter) Side
Bottom View: Rear (Feed/Distribution) Side

3. INSTALLATION

3.1. Inspecting the Product

The OHC is shipped mounted on a skid. Remove the bolts, unpack the unit, and dispose of the packaging material.

-INSPECTION NOTE-

Visually inspect the unit for damages prior to installation. If the equipment was damaged in transit, immediately report the extent of the damage to the transportation company.

3.2. Following and Using Safety Precautions

Read the following site and safety tips, cautions, and warnings, then proceed with the paragraphs that follow.

- For installation, follow all National Electrical Codes (NEC) ANSI/NFPA 70, local, environmental, workplace, and company codes, safety procedures, and practices.
- Minimum spacing between the accessories and components and the housing for ITE equipment shall be maintained for safe operation of the equipment when installed in accordance with NEC ANSI/NFPA 70.
- Read all instructions, warnings and cautions on the equipment and in the documentation shipped with the product.
- Always connect ground connections first.
- Do not place this product on weak or unstable surfaces which may allow the product to fall, resulting in potentially serious damage(s) to persons or product.
- Only authorized trained personnel shall install the OHC.
- In windy conditions, be sure to engage the door latches to secure the door in a stationary position.

3.3. Obtaining Tools and Equipment

Obtain the following recommended or needed items for installing the OHC.

- Sufficient length and quantities of fiber cable (or pigtails)
- Cable scoring, opening, and cutting tools for cable sheathing, shields, wrappings, strength members and buffer tubes
- Cable, tube, wire, and fiber cleaning materials
- Protective and/or insulated work gloves
- Safety glasses
- Tape measure
- Marking utensil
- #6 ground wire or rod and earth ground materials
- Bond strap (optional, from cable bond clamp to bond post)
- Any exterior cable strain relief, per company practice
- Slotted and Phillips screwdrivers
- Assorted cable ties, clips, or fasteners (optional)
- Can wrench (216 type tool)
- Derrick for lifting
- Level

3.4. Preparing the Installation Site

Observe the following site preparation recommendations.

- Leave adequate horizontal and vertical space between multiple installations to allow for proper cable access, as well as enough room around the enclosure to open the door(s).
- The site must meet minimal personnel and equipment safety requirements.
- The distance from the cable entry point should be consistent with local installation practices.
- The pad must be able to support the weight of the OHC.
- Run all fiber and copper facilities to the site.

3.5. Lifting the OHC

See Table 1 for OHC weight. Charles recommends the following procedure for lifting the OHC.

3.5.1. Required Equipment

- One derrick (crane) capable of lifting the OHC
- Spreader bar
- Two lifting slings or chains with each having a 2,500 lbs. capacity
- Connecting links to attach slings to the OHC's lifting brackets
- 75-ft. long tagline rope

Insert the lifting sling connecting links securely through each of the lifting brackets as shown in Figure 4.

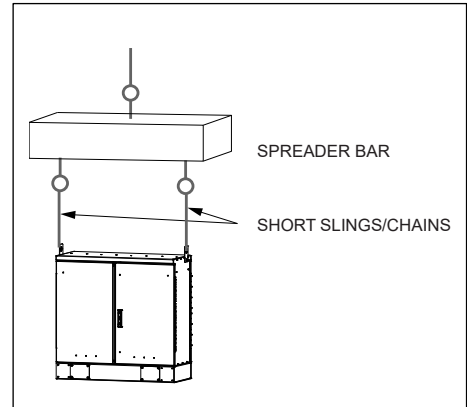



Figure 4 Lifting the OHC

3.5.2. Warnings and Specific Safety Precautions

	WARNING	Improper hoisting equipment and unsafe lifting procedures can result in serious injury or death
---	----------------	--

Observe the following local safety procedures when performing the tasks in this section.

- Keep the OHC away from any power lines.
- Keep bystanders away from the work operations at all times.
- Only trained operators shall operate the crane for lifting and setting the OHC.
- Do not suspend loads over people or equipment.
- All persons working with hoisting equipment shall wear standard safety gear according to local practices including safety helmets and steel-toed shoes.
- Do not operate the hoisting equipment until all stabilizer are extended and in firm contact with the ground or adequate support structure.
- Do not attempt to retract or extend the stabilizers while a load is suspended.

3.6. Mounting the OHC

The OHC can be mounted on a new or existing concrete or composite pad. Charles recommends the CPAD-S Universal composite pad. A loose gasket is provided for placing the OHC on a concrete pad. If the gasket becomes damaged during installation, order a replacement under part number 39-001462-0. The gasket is not needed if mounting on a CPAD. Ensure that the unit is level.

3.6.1. Mounting the OHC on a CPAD

First, follow the instructions that ship with the CPAD to ensure that the CPAD is securely installed in the ground. Then proceed to mount the OHC on the CPAD. Six customer supplied, corrosion resistant, 1/2"-13, 2" long fully threaded hex head bolts with flat and lock washers are required for mounting the OHC to the CPAD. Use the following steps to mount the OHC to a CPAD.

1. Clean any debris from the CPAD.
2. Remove the plinth cover panel to allow access to mounting holes.
3. Mount the OHC according to the instructions that come with the CPAD.
4. Once the OHC is secured, remove the slings and tagline. Replace the plinth cover panel.

3.6.2. Constructing a New Pad

- Use only concrete for new pad construction. Do not use substitute materials since they lack the rigidity for OHC placement.
- Observe local building practices for pad construction. Charles recommends that the pad should extend a minimum of 8” beyond the OHC base on all sides.
- Use a minimum of 6” of sand or gravel as a base for the pad for leveling purposes.
- Figure 2 shows the required conduit openings and mounting hole dimensions for entering/mounting the bottom of the OHC. Use these dimensions when designing the pad.

	WARNING	<p>When pad mounting, the compression strength of the pad must be at least 4000 psi as determined by ASTM C39 test of compression strength of concrete cylinders.</p> <p>The slump of the concrete shall be 2” to 4” as determined by ASTM C143 test method.</p>
---	----------------	--

3.6.3. Mounting the OHC on a Concrete Pad

Six customer supplied corrosion resistant 1/2”-13 hex head bolts with anchors are required for mounting the OHC to the concrete pad. Use the following steps to mount the OHC to a pad.

1. Layout, drill, and set the 1/2” anchors per manufacturer’s recommendations. The embedment depth is not to exceed 3.5”. Use the gasket as a mounting hole location template.
2. Clean any debris from the concrete pad.
3. Install the gasket by positioning it on the pad so that it is underneath the bottom of the OHC when the cabinet is installed. Line up the gasket so that the cutouts are in proper position around the conduit opening and the bolt holes
4. Remove the plinth cover panel to allow access to mounting holes.
5. Ensure that the OHC is parallel to the pad surface as it is placed onto the pad and that it aligns with the holes in the pad and the gasket. Dress the cable/conduit so that it aligns with the OHC openings as it is lowered onto the pad.
6. Place the OHC on the pad. Loosen the slings so that all the weight is on the pad. Check that the OHC is properly aligned and level.
7. Secure the OHC to the pad using the 1/2”-13 hex head bolts. Tighten all bolts securely.
8. Once the OHC is secured, remove the slings and tagline. Replace the plinth cover panel.

4. FIBER ROUTING

4.1. Splitter Side

The splitter connections are on the opposite side of the OHC from the feed and distribution connections. Route fiber fanouts from the feed input ports at the top of the cabinet to the splitter input connector.

The OHC can support a maximum of 56 splitters, depending on the configuration, with 32 outputs per splitter. Splitter installation starts at the #1 position on the splitter shelf. For each subsequent splitter installed, remove the divider panel and re-install it in the next slot. Connect splitter outputs to the distribution ports below the feed input ports.

Use the bend controls as needed to prevent strain, manage slack, and ensure the correct bending radius (Figure 5).

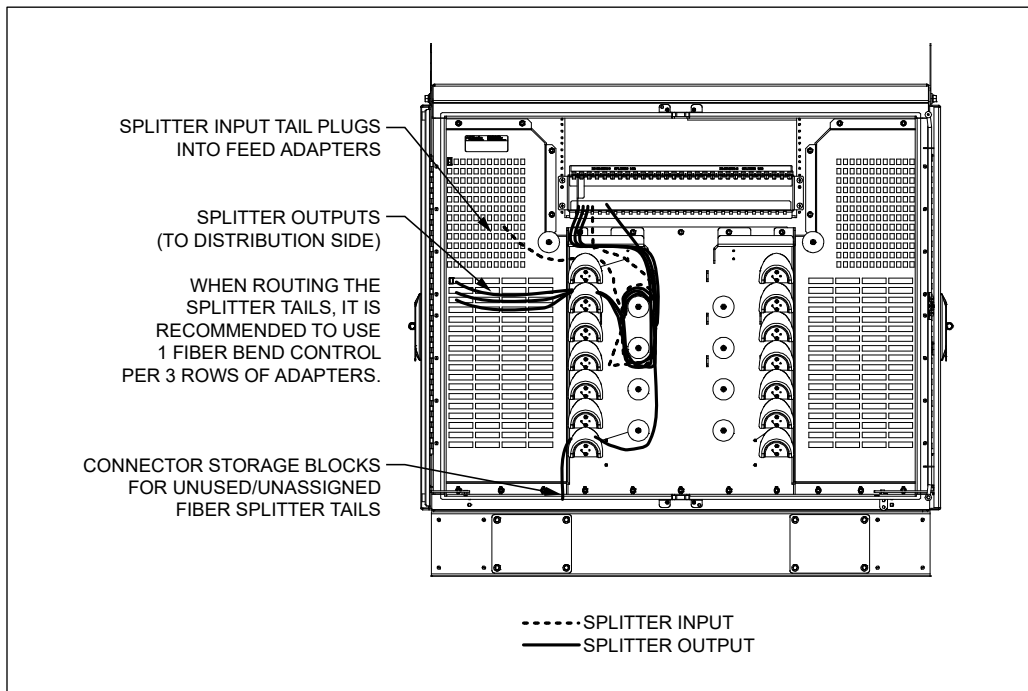

Figure 5 Splitter Side Fiber Routing

4.2. Feed Cable

Feed fibers are typically installed at the factory. For field-installed cables, follow these steps.

1. Route feed cable through the bottom cutout and upward through one of the knockouts on the floor of the cabinet.
2. Secure to the cable attachment hardware with a hose clamp.
3. Mark the cable sheathing between the two bolts on the attachment piece and remove the sheathing from the mark to the end of the cable (Figure 6).
4. Secure a bond clamp to the cable and use a bond strap to connect to the bond bar on the bottom of the cabinet (Figure 7).
5. Route feed buffer tubes around the basket, using the tie-down points and cable bend controls provided. Observe the proper bending radius for all buffer tubes. (Figure 8).
6. Connect fiber fanouts to the input ports for the splitters. Observe the proper bending radius for all fanouts (Figure 8).

4.3. Distribution Cable

Distribution fibers are typically installed at the factory. For field-installed cables, follow these steps.

1. Route distribution cable through the bottom cutout and upward through one of the knockouts on the floor of the cabinet.
2. Secure to the cable attachment hardware with a hose clamp.
3. Mark the cable sheathing between the two bolts on the attachment piece and remove the sheathing from the mark to the end of the cable (Figure 6).
4. Secure a bond clamp to the cable and use a bond strap to connect to the bond bar on the bottom of the cabinet (Figure 7).
5. Route distribution buffer tubes around the basket, using the tie-down points and cable bend controls provided. Observe the proper bending radius for all buffer tubes. (Figure 8).
6. Connect fiber fanouts to the output ports from the splitters. Observe the proper bending radius for all fanouts (Figure 8).

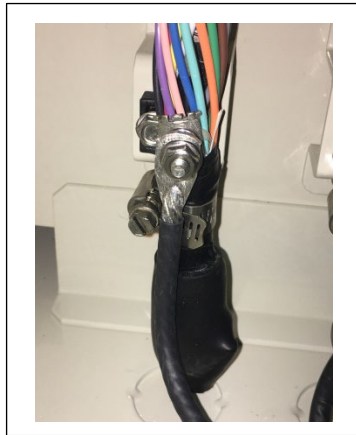

Figure 6
Cable Connected to Cable Attachment Hardware



Figure 7
Cable Attachment Hardware Connected to Ground Bar

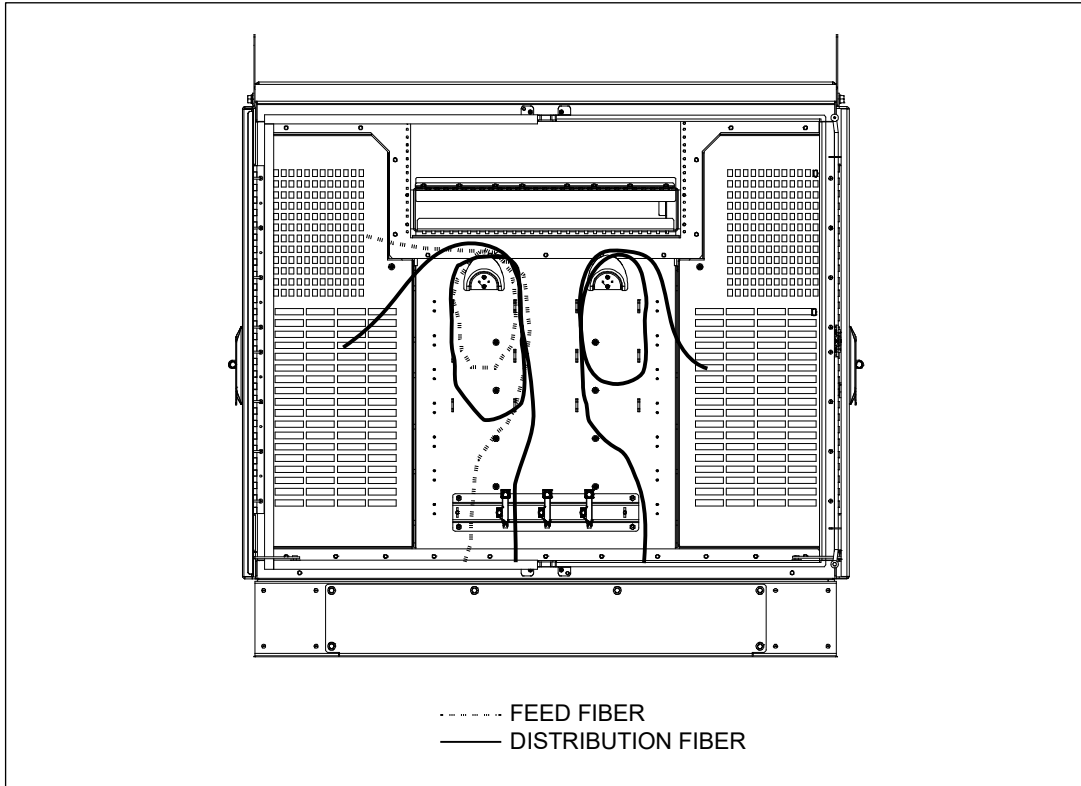

Figure 8 Feed and Distribution Routing, Single Fiber Shown

4.4. Conduit Seals

All conduit openings on the OHC must be completely sealed with a duct seal compound to prevent moisture from entering the OHC. Use a moldable, flame-retardant putty style duct seal material. Do not use an expanding foam seal. Mold the putty so that the open space around the wire or conduit is completely sealed, as shown in Figure 9. If the openings must be accessed at any time, remove the putty and set it aside. When work is complete, re-mold the putty to re-seal the opening.

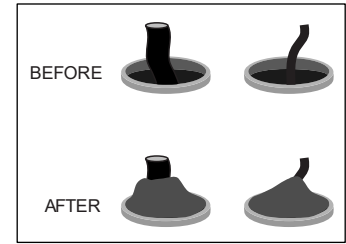

Figure 9 Applying Putty Seal

5. PERIODIC MAINTENANCE

In the event that the enclosure needs to be opened in freezing conditions, a narrow, pointed metallic object such as a screwdriver or chisel, along with a non-metallic device like a rubber mallet, may be used to remove excessive ice buildup around the door and locking mechanism. A commercial aerosol de-icer spray can be used to free up locks and latches if needed.

6. TECHNICAL ASSISTANCE AND REPAIR SERVICE

For questions on product repair or if technical assistance is required, contact Charles Technical Support.

847-806-8500
techserv@charlesindustries.com (email)
<http://www.charlesindustries.com/techserv.htm>

7. WARRANTY & CUSTOMER SERVICE

Charles Industries LLC offers a one-year warranty on the OHC product. The Charles warranty is limited to the operation of the OHC hardware as described in this documentation and does not cover equipment that may be integrated by a third party. The terms and conditions applicable to any specific sale of product shall be defined in the resulting sales contract. For questions on warranty or other customer service assistance, contact your Charles Customer Service Representative.

847-806-6300
mktserv@charlesindustries.com (email)
http://www.charlesindustries.com/main/telecom_sales_support.htm

8. SPECIFICATIONS

Physical	
Dimensions and Weight	46"Hx46"Wx19"D, Cabinet weight: Approx. 180 lbs. 144-fiber cable weight: 26 lbs. (qty 1) 288-fiber cable weight: 35 lbs.(qty 3) Total weight: 311 lbs.
Materials	0.125 aluminum
Color	Off-white
Environmental	
Operating Temp. Range, Outside Enclosure	-40° to +115°F, -40° to 46°C
Operating Temp Range, Inside Enclosure	-40° to +149°F, -40° to 65°C
Humidity	0 to 95% (non-condensing)
Altitude	Up to 2,000 meters (6560 feet)
Kits and Replacement Parts	
Touch-up Paint	02-000290-0
216 Type Security Tool	07-002070-0
Shim Kit for Leveling	97-000010-0
Replacement Gasket	39-001462-0
Optional Composite Mounting Pad	CPAD-S2BUNI4924 or CPAD-BH3048xxxx
Swing Handle	39-000148-0
1/4 Turn Latch with Padlock Hasp	39-000311-0

Table 1 OHC Specifications