

Figure 1. Typical CMPH Enclosure, Closed View

## Installation Instructions

for the

### Charles Multi-Purpose Housing (CMPH™) 5500 Series Enclosure

#### 1. GENERAL

##### 1.1 Document Purpose

This document provides installation instructions for the Charles Multi-Purpose Housing (CMPH™) 5500 Series enclosure, which provides a quick and easy way to attach, mount, and protect various types and quantities of copper and fiber cables, splices, cases, and equipment in a protective, outside plant (OSP), above-ground enclosure. See Figure 1 and Figure 2 for views of a typical CMPH model, Table 5 for general information on products in this series, or call Charles Industries (see Part 2) to request more information.

**- NOTE -**

Hereafter the Charles Multi-Purpose Housing will be commonly referred to as the "CMPH" or "enclosure." Specific model numbers are referenced where key differences apply.

##### 1.2 Document Status

Whenever this document is updated, the reason will be stated in this paragraph.

##### 1.3 Product Purpose and Description

The CMPH is a non-metallic, two-piece, rectangular, OSP enclosure that offers easy installation, superior structural strength, 360° technician access, generous internal equipment and cable storage capacity, and protection against corrosion, floods, fire, weather, dirt, insects, intrusion, dents and impact. The CMPH contains a base, a dome, and internal framework. The base has corrugated or ribbed walls, an open top, and an open bottom. Easy replacement installations and easy underground cable access is provided via the open bot-

tom. The top piece of the CMPH is the dome, designed to overlap the base for a flood-protective bell-jar effect. Inside the CMPH, sturdy framework with splice bars and brackets provides versatile mounting options for equipment (such as fiber optic splice closures, terminal blocks, and cases) as well as storage, containment, and attachment options for various types, sizes, and quantities of conduit, innerduct, and cabling.

#### 1.4 Product Mounting Type and Location

The CMPH is an above-grade enclosure, the base of which is typically installed in a trench or hole in the ground up to the base's ground line indicator. The ribbed or corrugated base walls provide excellent stability in most soil types. The dome mounts on the base and protects all equipment installed or mounted inside the CMPH. Stake mounting is achieved by attaching a stake at the center of the interior side walls.

#### 1.5 Installation

See Table 1 to perform a new CMPH enclosure installation. Table 2 describes a new CMPH installation with stakes, and Table 3 describes an installation to replace an existing enclosure (rehabilitation installation).

**- GROUNDING WARNINGS -**

Always follow local codes and company practices for performing proper cable and site bonding and grounding, and perform all bonding and grounding prior to other electrical, fiber, and communications connections.

**- CABLE DAMAGE WARNINGS -**

Be careful not to damage any buried cables or service wires while digging either to expose cables or to prepare a hole or trench, or while driving stakes.

Buffer tubes and fibers are sensitive to excessive bending, pulling, and crushing forces. To avoid kinking of buffer tubes and fiber damage or breakage, exercise great care when working with fiber, and do not exceed or violate minimum bend radius requirements for fibers, buffer tubes, and cables.

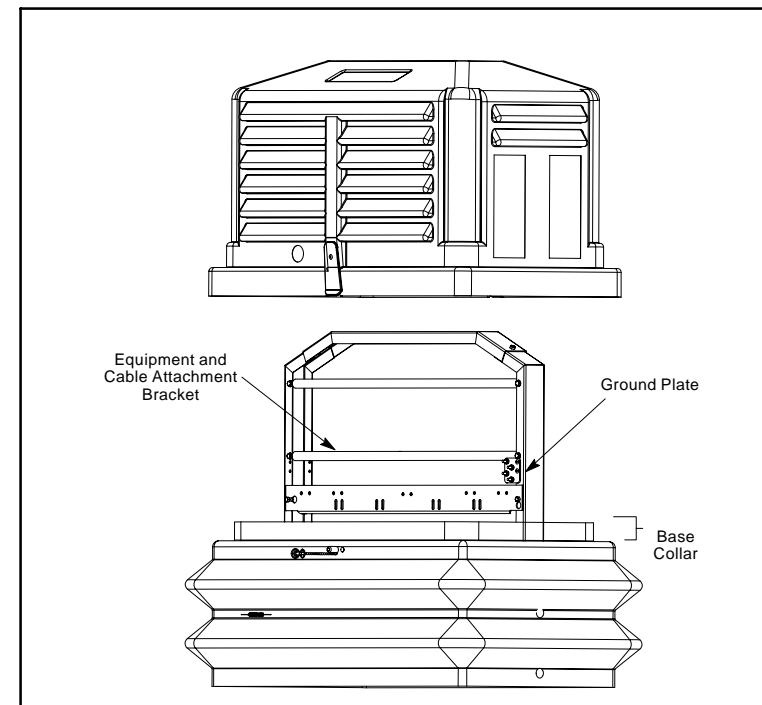

Figure 2. Typical CMPH Enclosure, Dome Lifted

**- BODILY HARM WARNINGS -**

**Risk of serious eye damage! Never look into the end of a fiber optic line or circuit nor use a magnifier in the presence of laser light or radiation. Always exercise caution when installing, testing, or performing maintenance on live circuits. If eye exposure to laser light or radiation has occurred or is suspected, immediately seek medical treatment by a professional eye care physician.**

Shards and cleaved glass fibers are very sharp and can easily pierce the skin. Do not let cut pieces of fiber stick to your clothing or drop in the work area where they can later cause injury. Use tweezers to pick up cut or broken pieces of glass fibers and place them on a loop of tape or in a container specifically meant for this purpose.

The corrugated metal or armor that may be present in the feed cable is very sharp at the cut or exposed edges. Extreme caution should be taken to prevent personal injury. Protective work gloves are recommended when handling armored cable.

Cable and fiber cleaning solvents may contain hazardous materials or harmful ingredients. Always read and follow the manufacturer's precautions, warnings, and instructions when working with cleaning solvents or products.

**- NOTE -**  
Never grasp or use the flap-latches as handles to lift the dome off the base; latch breakage and possible enclosure intrusion could result.

| Step # | Instruction   |
|--------|---|
| 1.     | <p><b>Obtain tools, materials and equipment.</b> Gather the following equipment to perform the CMPH installation.</p> <ul style="list-style-type: none"> <li>□ 216 tool or can wrench</li> <li>□ Charles CMPH model</li> <li>□ Scissors, knife or snips</li> <li>□ Level</li> <li>□ Measuring tape</li> <li>□ Soil tamping tool(s)</li> <li>□ Soil for backfill</li> <li>□ Site cleanup tools</li> <li>□ Trenching and digging equipment and tools</li> <li>□ Cable grounding materials and tools</li> <li>□ Cable opening and management equipment</li> <li>□ Clean, dry, pea gravel (3/8"-5/8" diameter)</li> <li>□ Conduit and conduit caps (optional)</li> <li>□ Wrenches or socket set</li> <li>□ Insulated work gloves (optional, to handle metallic stakes)</li> </ul> |
| 2.     | <p><b>Prepare trench. Do not damage any buried cables or wires while digging.</b> Dig and prepare the cable trench, per company practice.</p>   |
| 3.     | <p><b>Place cables (or conduit or innerduct) in trench.</b> Follow company practice to lay, place, and cut any cables and innerduct or conduit.</p>   |
| 4.     | <p><b>Unpack and inspect equipment.</b> Without damaging the CMPH exterior, remove the CMPH from its packaging. Inspect the unit upon delivery; if damaged in transit, report the damage to the shipping company.</p>   |
| 5.     | <p><b>Unlock the CMPH.</b> Unlock the CMPH using a 216 tool or can wrench at the two cup-washer screws (one at each side of the CMPH); turn the cup-washer screws counter-clockwise until they freely hang from their lanyard. When locked, the cup-washer screws prevent movement of the flap-latches.</p>   |
| 6.     | <p><b>Disengage the flap-latches.</b> Each limited-flexibility flap-latch contains a hole in it which accepts the round stand-off protruding from the side of the base collar. Each latch must be pulled out or away from base side wall just enough to clear the length of the protruding stand-off. Maintain the flexed or pulled-out latch position by temporarily inserting the cup-washer screw or an item of similar diameter or thickness under each latch (between the latch and the side wall). <b>Do not pry or flex the latches too far, only enough to clear the stand-off.</b> <b>Never grasp or use the flap-latches as handles to lift the dome off the base; latch breakage and possible enclosure intrusion could result.</b></p>                            |

| Table 1 (Continued) - Installing a New CMPH Enclosure |   |
|---|---|
| 7.  | <p><b>Remove the dome.</b> While the flap-latches are properly disengaged from the base stand-offs, grasp the ribs at each side of the dome and lift up to remove the dome from the base. The cup-washer screws remain attached to the base via the lanyard (or chain). Set aside the dome for later use.</p>   |
| 8.  | <p><b>Find and remove red plastic bag.</b> Remove the red bag labelled "moisture barrier" hanging on one of the frame's splice bars or brackets. Set it aside for later use.</p>  |
| 9.  | <p><b>Optional - Replacement or rehabilitation mountings only.</b> For applications to replace old enclosures, continue with the steps in Table 3.</p>  |
| 10.   | <p><b>Determine and mark base installation location.</b> To determine exactly where to place the base in the trench, use the base itself as a positioning template by placing it up over the top of the conduit, innerduct, or cables (route the cables through the base) and lowering the base to the ground. Analyze the site and position the base at its proposed final orientation and horizontal positioning in the trench or hole and adjust accordingly. Mark this proposed final spot by removing a shallow layer of top soil from around the outside perimeter of the base about 2-4 inches wider than the base. Remove the base and set it aside.</p>                |
| 11.   | <p><b>Dig a hole for the base. Caution: Avoid damaging buried cables, wires, innerduct, conduit or ground equipment whenever digging.</b> At and within the marked perimeter boundary, dig straight down to a depth of 9 inches. Do not dig too deep.</p>   |
| 12.   | <p><b>Optional - Stake mountings only.</b> For stake mounting applications, continue with the steps in Table 2.</p>   |
| 13.   | <p><b>Put base in hole or trench and route cable(s) through base.</b> Route the cables and conduit or innerduct up through the bottom of the base, then put the base in the prepared hole or trench.</p>  |
| 14.   | <p><b>Verify proper base depth.</b> Before backfilling, verify the base is at the proper depth, approximately 9 inches deep. Rest the base on solid or well-tamped soil when measuring this distance. Verify the base ground line indicator is at the same level as the final-grade ground line. Remove, add, or tamp more soil as necessary.</p>   |
| 15.   | <p><b>Level the base.</b> Verify the level (or plumb) of the base. Check the level at either the top surface of the base, or against one of the interior vertical channels of the metal frame. Check the level in both dimensions; front to back, and side to side. Make any needed base-bottom soil adjustments to get a good or true level or plumb line.</p>   |
| 16.   | <p><b>Prepare earth ground. Always follow local codes and company practice when preparing earth ground and when grounding cables or equipment.</b> If an earth ground is not present at the CMPH site and local code or practice requires an earth ground, prepare one now. Attach the earth ground to the CMPH's ground lug on the ground plate (Step 22) using a ground wire of proper gauge, per company practice.</p>   |
| 17.   | <p><b>Backfill and tamp outside the base.</b> With the base in place, backfill the trench or hole outside of the base. While backfilling, tamp the soil or fill and check the base level once or twice. Continue to add and tamp the soil until the soil is at the base ground-line mark.</p> <p><b>Backfill soil inside the base and tamp.</b> First plug, cap, or cover all channel, conduit, or innerduct openings. Then per company practice, backfill soil inside the base, tamping soil periodically, to the ground line mark. This adds stability and prevents any company-approved gravel (Step 19) from falling or slipping under the base sides when it is added.</p> |

| Table 1 (Continued) - Installing a New CMPH Enclosure |  |
|---|--|
| 18.   | <p>□ <b>Place the red-plastic bag or sheet.</b> Retrieve the provided, red-plastic, vapor-barrier bag previously set aside, cut it open on all but one long edge to make one large plastic sheet, verify it does not have any large holes in it (if it does, seal them with duct tape), and place it into the base on top of the soil fill. Completely cover the soil. Fit the bag around and encircle the cables, conduit, or innerduct, <u>spread it outward from the center, and press all sheet edges downward where they make contact with the base walls.</u> Alternately, cut a hole or "X" in the center of the sheet, drop the sheet down over the centered cables or conduit group, bring it all the way down to the tamped soil or fill, fit the sheet's inner hole edges snugly around the cables or conduit, and spread it out as underlined above. When installed properly, this sheet acts as a vapor barrier and aids moisture run-off into the soil. <b>Failure to use the plastic moisture-barrier bag on top of the soil significantly increases the risk of condensation inside the enclosure.</b></p> |
| 19.   | <p>□ <b>Add gravel inside the base.</b> Pour 3-5 vertical inches of company-approved gravel (gravel minimizes condensation and drains well) into the base (about to the top base rib, or 1" below any innerduct or conduit opening) on top of the soil. Use 5/8" (or less) diameter pea gravel, or clean, dry, non-porous, gravel rock only (cut stone retains more moisture). Five 18-pound bags work well. Spread out and level the gravel.</p>  |
| 20.   | <p>□ <b>End of base installation - determine next procedure.</b> If cable work will now be performed, continue with the next steps and consult local practices and equipment manufacturer instructions for the proper procedures. If further cable work will NOT be performed at this time, skip to Step 25 to close the CMPH enclosure.</p>   |
| 21.   | <p>□ <b>Perform cable routing and mounting.</b> Per company practice and local codes, perform all cable routing, mounting, and management procedures.</p>  |
| 22.   | <p>□ <b>Bond and strain-relief the cables.</b> Ground or bond the cable(s) to the ground posts provided on the ground plate. Perform cable strain relief and bonding per company practice.</p> <div style="text-align: right;"> </div>   |
| 23.   | <p>□ <b>Finish cable work &amp; equipment mounting.</b> Per company practice, perform all cable opening and splicing procedures, and equipment mountings and connections.</p>  |
| 24.   | <p>□ <b>Re-check cable management.</b> Verify all equipment and cabling is organized and will not contact the interior walls of the dome when installed (keep items at least 1" from the vertical plane of the base collar). This assures safe and smooth dome placement.</p>  |
| 25.   | <p>□ <b>Install dome.</b> Locate the dome and lift it up and over the interior framework and equipment. Lower the dome until it overlaps and self-latches to the base. Verify the stand-offs protrude through the holes in the latches (self-latch feature).</p> <div style="text-align: right;"> </div>   |
| 26.   | <p>□ <b>Lock the CMPH.</b> Lock the CMPH by re-inserting and turning the cup-washer screws clockwise into the threaded holes provided for them in the standoffs. Tighten the cup-washer screws with a 216 tool or can wrench.</p> <div style="text-align: right;"> </div>  |
| 27.   | <p>□ <b>End of CMPH placement. Clean up site.</b> If no more equipment or cable work will be performed at this time, clean up the site, fill and tamp any trenches, replace any removed sod, restore the landscape to its original condition, pick up all equipment, and optionally leave this document inside the CMPH for future reference.</p>  |

| Table 2. Installing the CMPH with New Charles Stakes   |  |
|--|--|
| Step #   | Instructions   |
| <p><i>Charles offers some CMPH models which include two mounting stakes (either 30", 36", or 42" long). All stakes have identical hole patterns. This table describes how to install these models.</i></p> |  |
| 1.   | <p>□ <b>Prepare the CMPH, trench, and cable.</b> Perform Steps 1-11 of Table 1 to open the enclosure and prepare the hole or trench and the cables or conduit. Verify the base installation site is ready and suitable for metallic stakes.</p>  |
| 2.   | <p>□ <b>Remove stakes from CMPH framework.</b> Two mounting stakes are packed with the CMPH and attached to the frame with cable ties. Detach the stakes from the frame and remove the packing used for shipping purposes.</p> <div style="text-align: right;"> </div>   |
| 3.   | <p>□ <b>Attach stakes to base.</b> On the inside of the base, remove the nuts and washers from the bolts (which are 4" apart) that secure the frame channels in place. While holding the frame channels in place, insert the top of each stake into the base from the bottom. Rotate each stake to align the holes in the stake with the bolts protruding through the frame channels and through the side wall of the base. Attach the lock washers and nuts (removed previously) to secure both the mounting stakes and frame channels in place.</p> <div style="text-align: right;"> </div>  |
| 4.   | <p>□ <b>Verify hole or trench accommodates stake length.</b> Lift the base and attempt to place it back in place in the trench or hole. If the trench is deep enough to accommodate the length of stake protruding from the bottom of the base, skip the rest of this step. If the hole or trench is not deep enough to accept the stakes, and the weight of the base is not enough to drive the stakes the length needed to allow the base to rest at its proper depth, then once again use the base as a template to mark the exact stake locations in the ground where more soil must be removed. Remove the base from the hole, and at the stake-hole indentations, dig down just enough to accommodate the length of the stake.</p> |
| 5.   | <p>□ <b>Set base in place, bring cables into base.</b> When the hole is deep enough for the stakes, again lift the base by its walls or ribs and set it back into the hole, being sure to enclose or encompass within the base all cables, innerduct, conduit or equipment present at the site and intended for storage inside the enclosure.</p>  |
| 6.   | <p>□ <b>Finish the installation.</b> Perform Steps 14 through 27 in Table 1 to finish the installation. Be sure to backfill and firmly tamp soil into the stake holes when backfilling.</p>  |

| Table 3. Installing Replacement or Rehabilitation Enclosures   |   |
|--|---|
| Step #   | Instructions  |
| <p><i>The Charles CMPH has the same footprint as the UPC 1200 series. These instructions describe how to replace a UPC 1200 with a Charles CMPH. To replace enclosures with smaller footprints, remove the smaller enclosure and dig a wider hole, as described in Step 10 of Table 1.</i></p> |   |
| 1.   | <p>□ <b>Prepare the base, trench, and cables.</b> Locate the old or existing enclosure (such as the UPC 1200 series) to be replaced. Perform Steps 1-8 of Table 1 to prepare the new Charles CMPH enclosure, the hole or trench, and the cables or conduit (skip Steps 2-3 if trenching and new cable placement is not required).</p>   |
| 2.   | <p>□ <b>Dig around existing enclosure.</b> Remove the dirt from around the existing enclosure. Dig deep enough to allow the enclosure to be lifted and removed.</p>   |
| 3.   | <p>□ <b>Prepare existing enclosure for removal.</b> Remove the bottom panels of the UPC 1200. Locate the mounting stakes and remove the nuts and bolts from them. Remove all attachments to the enclosure, including cable supports and tie wraps, bonding connections, and grounding connections.</p>  |
| 4.   | <p>□ <b>Remove the old enclosure.</b> Completely remove the existing enclosure.</p>   |
| 5.   | <p>□ <b>Protect cables and connections.</b> Per company practice, wrap the existing splice as tightly as possible without damaging the wire (or fiber) connections.</p>   |
| 6.   | <p>□ <b>Analyze condition of existing mounting stakes.</b> Inspect the existing mounting stakes for possible re-use. If they are deteriorated, bent, out of alignment, or have a hole pattern that will not work with the Charles CMPH base, carefully remove the stakes and install new ones per company practice (consult Table 2 if desired).</p>  |
| 7.   | <p>□ <b>Optional - remove the CMPH's horizontal splice bars and/or ground bracket.</b> Analyze whether or not it will be necessary to temporarily remove any of the CMPH's internal, horizontal, supportive splice bars or brackets in order to fit the existing cabling, connections, splices, and equipment into the CMPH during the base installation. After base installation, re-attach the bars and brackets (Step 10).</p>         |
| 8.   | <p>□ <b>Set base in place.</b> Lift the base over the existing cabling and equipment, and route the wrapped splice and all equipment up through the base bottom while lowering the base to the bottom of the hole. If the existing stakes were used, verify they are inside the base. If new stakes were attached to the base, insure the hole accommodates them. Perform Steps 14-15 of Table 1 for the proper base depth and level.</p> |
| 9.   | <p>□ <b>Attach base to re-used stakes.</b> Remove the nuts and washers from the 4 bolts located inside the CMPH base that secure the frame channels in place (2 bolts on each side, 4" apart). Manipulate the base and/or stake tops so the re-used stakes abut the interior of the base walls. Align the base bolts with the stake holes, and re-attach the washers and nuts onto the bolts. Firmly tighten nuts.</p>                    |
| 10.  | <p>□ <b>Attach cables to bars and brackets.</b> If the splice bars or brackets were removed, re-install them now in the best positions to support (and ground) the equipment. Per company practice, attach or mount all cables and equipment to the internal framework (bars, brackets) of the CMPH. Re-attach any grounding, bonding, and cable connections previously unattached to remove the old enclosure.</p>                       |
| 11.  | <p>□ <b>Close the CMPH and clean the site.</b> Perform Steps 24 to 27 of Table 1 to close the CMPH and restore the site to its previous condition.</p>  |

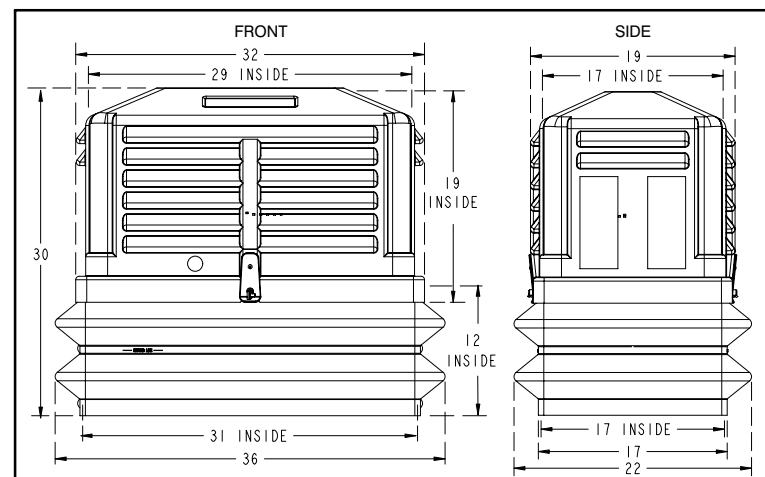

Figure 3. Front and Side Views of CMPH-5500

| Table 4. Physical Specifications |            |         |
|----------------------------------|------------|---------|
| Feature                          | U.S.       | Metric  |
| Height, overall                  | 30 in.     | 76.2 cm |
| Height, base only, incl. collar  | 12.437 in. | 31.6 cm |
| Height, dome only                | 19.5 in.   | 49.5 cm |
| Depth, base                      | 22 in.     | 55.9 cm |
| Depth, dome                      | 19 in.     | 48.3 cm |
| Width, base                      | 36 in.     | 91.4 cm |
| Width, dome                      | 32 in.     | 81.3 cm |
| Weight, dome                     | 17 lbs.    | 7.7 Kg  |
| Weight, base                     | 21 lbs.    | 9.5 Kg  |
| Weight, two 30" stakes           | 5 lbs.     | 2.2 Kg  |
| Weight, two 36" stakes           | 6 lbs.     | 2.7 Kg  |
| Weight, two 42" stakes           | 7 lbs.     | 3.2 Kg  |

NOTE: All dimensions and weights are approximate.

| Table 5. Model Number Ordering Information and Options |   |
|--|---|
| Model #  | Description   |
| CMPH-55ABCD  | <p>Charles Multi-Purpose Housing. All sturdy self-locking CMPH models come with a polyethylene base, an overlapping polyethylene dome, and internal metallic framework for mounting equipment and cabling, a ground plate with a ground lug and bond posts, instructions, and a plastic moisture-barrier sheet.</p> <p>Order model CMPH-55_A_B_C_D, where A, B, C, or D represents one of the features as listed below.</p> <p>A (stake size): 0 = No stakes. 1 = 30" stakes. 2 = 36" stakes. 3 = 42" stakes.<br/>           B (bar or bracket type): 0 = Standard copper type. F = Fiber type (offset, see Step 2 Table 2).<br/>           C (material): F = Flame retardant. N = Non-flame retardant.</p> |
| <b>Optional Equipment for Use with CMPHs</b>           |   |
| CMPH-BOND10  | <p>Package of 10 ground plates, each plate contains a ground lug and 6 bond posts. Attaches to internal, horizontal, ground bracket.</p> <div style="text-align: right;"> </div>  |
| CKPL-99  | <p>Mounting bracket kit for either one 12-pair or one 25-pair terminal block. Includes 2 brackets and mounting hardware.</p> <div style="text-align: right;"> </div>  |

Various replacement and optional parts are available, including bracket kits for vault-mounting. Contact Charles Industries for more information.

## 2. CUSTOMER TECHNICAL SERVICE

If technical assistance or customer service is required, contact Charles Industries by calling or using one of the following options:

847-806-8500 (Tech. Service local)      847-806-6300 (Customer Service)  
 800-607-8500 (Tech. Service toll-free)      847-806-6653 (Customer Service FAX)  
 847-806-8556 (Tech. Service FAX)      mktsterv@charlesindustries.com (email)  
 techsterv@charlesindustries.com (email)      www.charlesindustries.com (website)