

Charles 6” Plinths for CUBE-SS4C2288V1 and CUBE-SS4C2288V2

97-PLNTHSS8V1 and 97-PLNTHSS8V2

General Description and Installation

- 1. GENERAL INTRODUCTION 1
 - 1.1. Document Purpose 1
 - 1.2. Product Purpose..... 1
- 2. INSTALLATION..... 2
 - 2.1. Inspecting the Product 2
 - 2.2. Following and Using Safety Precautions..... 2
 - 2.3. Obtaining Tools and Equipment 2
 - 2.4. Mounting the Kit..... 2
- 3. TECHNICAL ASSISTANCE AND REPAIR SERVICE 4
- 4. WARRANTY & CUSTOMER SERVICE 4
- 5. SPECIFICATIONS..... 4

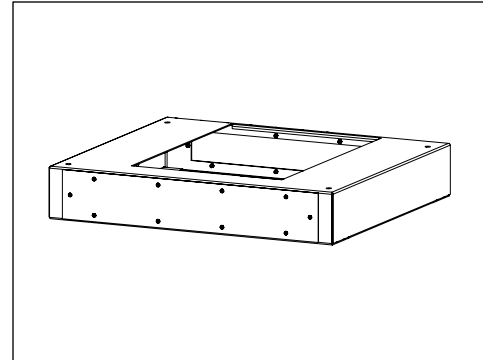

Figure 1 Plinth

1. GENERAL INTRODUCTION

1.1. Document Purpose

This document provides general information for the 97-PLNTHSS8V2 6” plinth kit for the CUBE-SS4C2288V2 cabinets. Figure 1 shows the plinth. Mounting hardware is not shown.

-NOTE-

Hereafter, the Charles 97-PLNTHSS8V2 6” plinth kit will be referred to as the “kit.” The Charles CUBE-SS4C2288V1 and CUBE-SS4C2288V2 will be referred to as the “CUBE.”

1.2. Product Purpose

The kit is intended for use in mounting the CUBE on a concrete pad. The plinth provides a storage space for cable slack. The kit includes hardware for mounting the CUBE onto the plinth. Hardware for securing the plinth to the concrete pad is customer supplied. Plinth dimensions are shown in Figure 2.

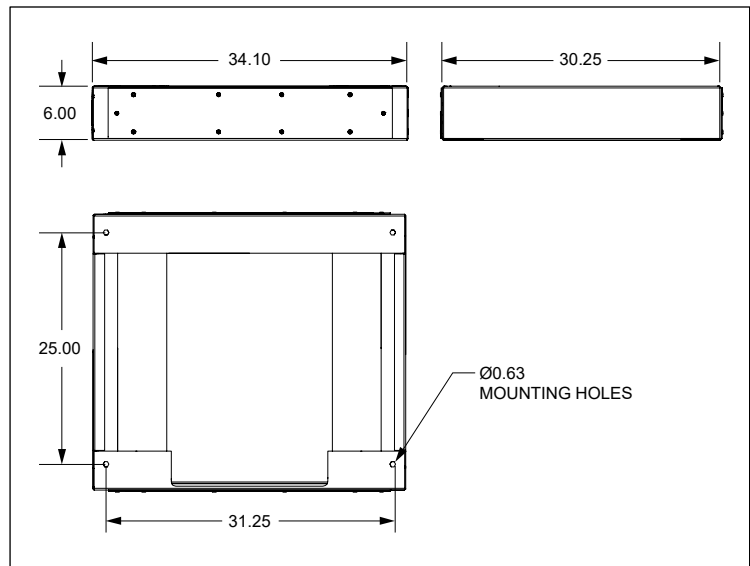

Figure 2 Dimensions (in inches)

2. INSTALLATION

2.1. Inspecting the Product

The kit is shipped in a carton. Unpack the unit, and dispose of the packaging material.

-INSPECTION NOTE-

Visually inspect the unit for damages prior to installation. If the equipment was damaged in transit, immediately report the extent of the damage to the transportation company.

2.2. Following and Using Safety Precautions

Read the following site and safety tips, cautions, and warnings, then proceed with the paragraphs that follow.

- For installation, follow all National Electrical Codes (NEC) ANSI/NFPA 70, local, environmental, workplace, and company codes, safety procedures, and practices.
- Minimum spacing between the accessories and components and the housing for ITE equipment shall be maintained for safe operation of the equipment when installed in accordance with NEC ANSI/NFPA 70.
- Read all instructions, warnings and cautions on the equipment and in the documentation shipped with the product.
- Always connect ground connections first.
- Do not place this product on weak or unstable surfaces which may allow the product to fall, resulting in potentially serious damage(s) to persons or product.
- Only authorized trained personnel shall install the kit.

2.3. Obtaining Tools and Equipment

Obtain the following recommended or needed items for installing the kit.

- Protective and/or insulated work gloves
- Safety glasses
- Any exterior cable strain relief, per company practice
- Slotted, hex, and Phillips screwdrivers
- Torque wrench

2.4. Mounting the Kit

2.4.1. Torque Requirements

Torque all hardware as shown below (unless otherwise noted). These values apply to SAE Grade 1 & 2 Low Carbon Steel, ASTM A307 Low Carbon Steel, and Stainless Steel Grade 18-8.

Thread Size	In-lbs	Ft-lbs
4-40	4±10%	
6-32	8±10%	
8-32	16±10%	
10-32	26±10%	
12-24	50±10%	
1/4-20/M6	60±5%	5±5%
5/16-18	125±5%	10.4±5%
3/8-16	180±5%	15.0±5%
1/2-13	500±2%	41.7±2%
5/8-11	1000±1%	83.3±1%

2.4.2. Installing the Kit

Prepare the concrete pad according to the instructions that ship with the CUBE. See Figure 2 for mounting hole dimensions for the plinth.

Four customer supplied, corrosion resistant, 1/2"-13 hex head bolts with anchors are required for mounting the CUBE and the kit to the concrete pad. Use the following steps for mounting. Note that the gasket shown in this section ships with the CUBE.

1. Layout, drill, and set the 1/2" anchors per manufacturer's recommendations. The embedment depth is not to exceed 3.5". Use the gasket as a mounting hole location template.
2. Clean any debris from the concrete pad.
3. Install the gasket by positioning it on the pad with all mounting holes aligned with the holes on the pad as shown in Figure 3.
4. Position the plinth so that the mounting holes in the plinth are aligned with those on the gasket and the pad.
5. Secure the plinth to the pad using four customer supplied, corrosion resistant, 1/2"-13 hex head bolts with anchors.
6. See the instructions that ship with the CUBE for lifting and moving the CUBE.
7. Open the CUBE door to allow access to mounting holes.
8. Ensure that the CUBE is parallel to the pad and plinth surface as it is placed onto the plinth and that it aligns with the holes in the plinth.
9. Lower the CUBE onto the plinth, ensuring that the mounting holes on the CUBE are aligned with the holes on top of the plinth (Figure 3).
10. Secure the CUBE to the plinth using hardware that ships with the kit.

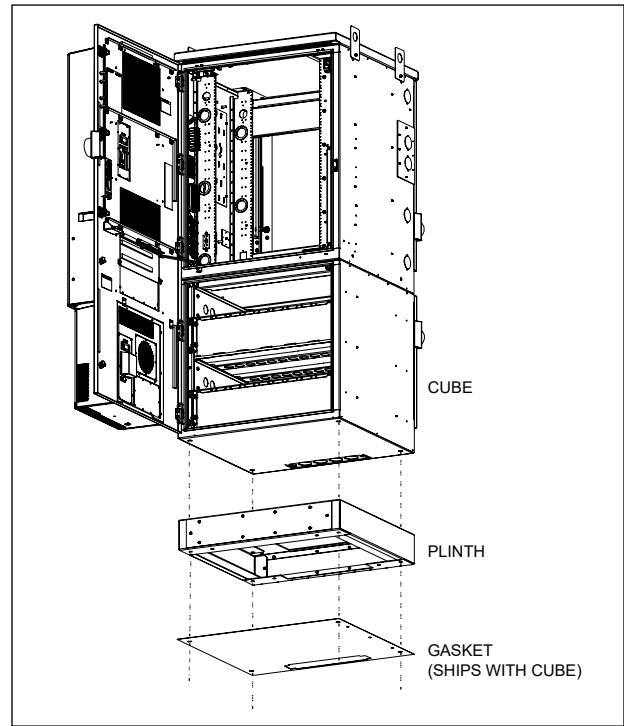

Figure 3
Mount Plinth with Gasket and CUBE

2.4.3. Opening the Plinth

To access the storage space inside the plinth, remove the plate on either the front or rear plinth panels by removing the ten screws from the outside (Figure 4). Reinstall the plate when finished.

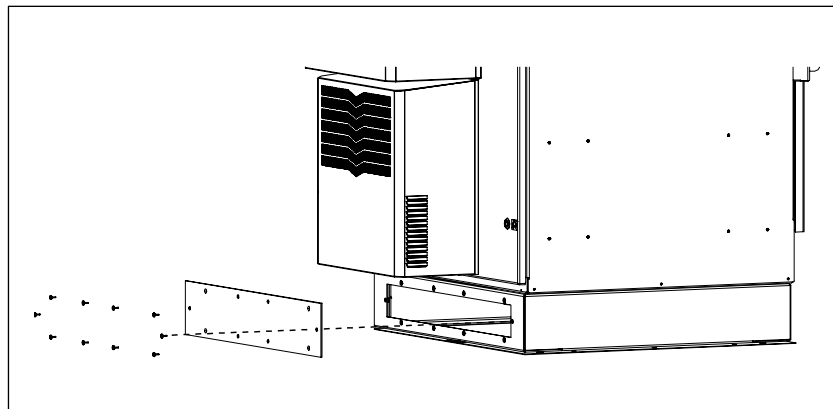

Figure 4 **Access Storage Area**

3. TECHNICAL ASSISTANCE AND REPAIR SERVICE

For questions on product repair or if technical assistance is required, contact Charles Technical Support.

847-806-8500
techserv@charlesindustries.com (email)
<http://www.charlesindustries.com/techserv.htm>

4. WARRANTY & CUSTOMER SERVICE

Charles Industries LLC offers a one-year warranty on the kit product. The Charles warranty is limited to the operation of the kit hardware as described in this documentation and does not cover equipment that may be integrated by a third party. The terms and conditions applicable to any specific sale of product shall be defined in the resulting sales contract. For questions on warranty or other customer service assistance, contact your Charles Customer Service Representative.

847-806-6300
mktserv@charlesindustries.com (email)
http://www.charlesindustries.com/main/telecom_sales_support.htm

5. SPECIFICATIONS

Physical	
Weight	Approx. 54 lbs. as shipped
Material	0.125" aluminum with steel structural channels
Color	Off-white
Touch-up Paint	02-000290-0

Table 1 Kit Specifications