

Installation Instructions: Vault Mount Square Base

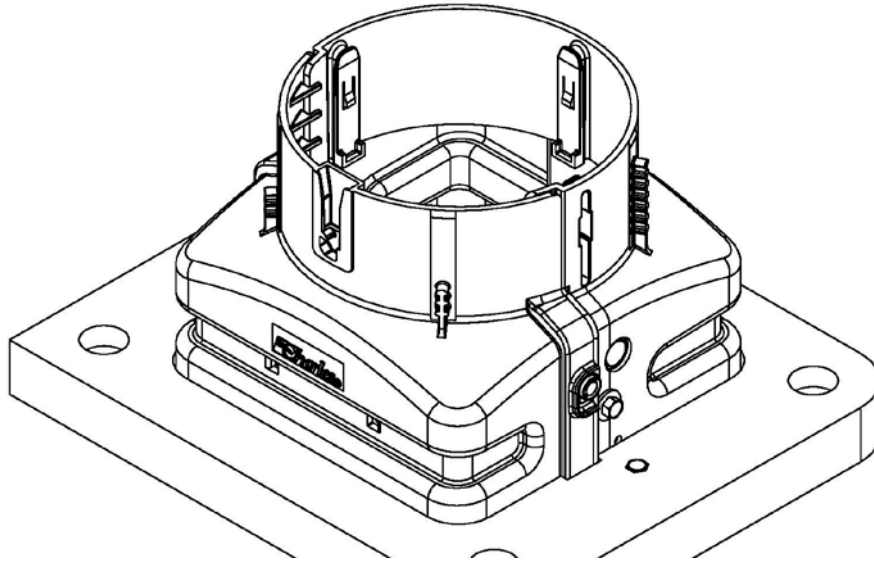

These instructions are intended for the installation of Charles Industries vault mounted square base. The following tools will be needed to complete the installation:

- 216 Tool
- 3/8" socket wrench with 3/8" socket or a 3/8" open end wrench

Note: Failure to follow this procedure could result in the kit not performing properly.

Step	Action
1.	Remove the hardware components from the plastic bag and inventory its content. There should be two (2) mounting brackets, two (2) 3/8"-16 x 4" hex bolts, two (2) 3/8"-16 x 1.5" hex bolts, two (2) 3/8"-16 x .75" hex bolts, four (4) 3/8"-16 hex nuts, eight (8) 3/8" flat washers, four (4) 3/8" split lock washers. <i>If missing hardware, call Charles Industries Technical Support at 800-607-8500.</i> Included separately: One (1) foam moisture barrier. <i>*Moisture barrier not included with all vault base assemblies.</i>
2.	Using the figure below, attach the base to the vault lid making sure to tighten the nuts securely.
3.	Install the foam moisture barrier.
4.	Install the dome onto the base, making sure the lock is engaged.

3/8"-16 x 1 1/2" Hex Bolt

Moisture Barrier
(not included with all vault base assemblies)

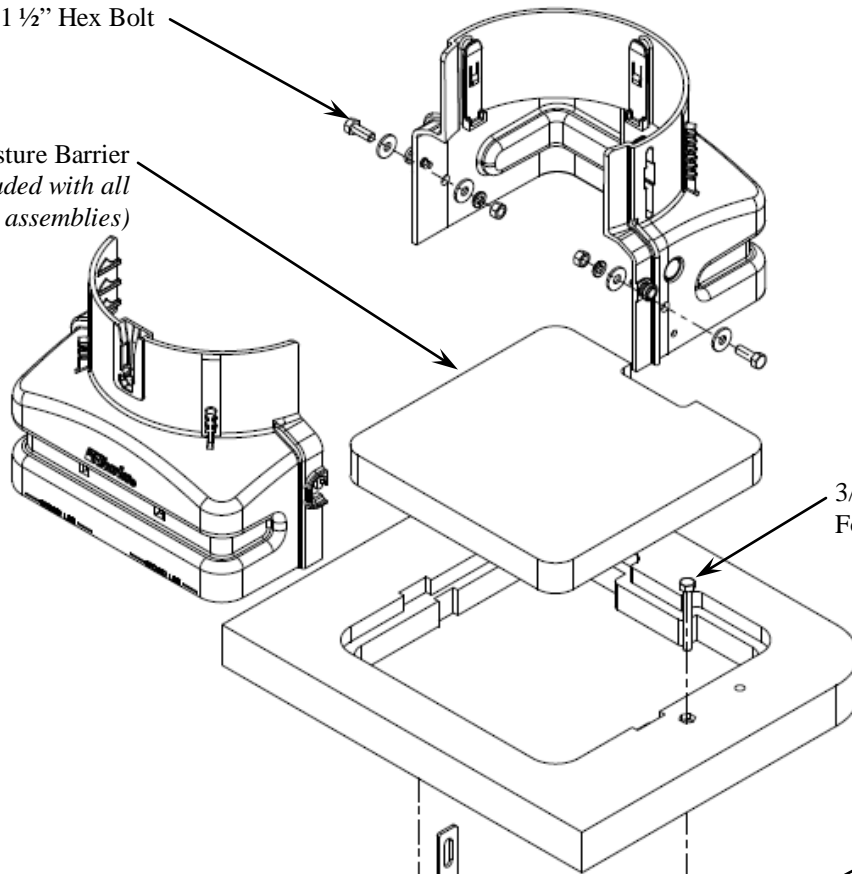

3/8"-16 x 4" Hex Bolt
For thru hole mounting to lid

3/8"-16 x .75" Hex Bolt
For blind insert hole
mounting to lid

Mounting Bracket

3/8" Flat Washer

3/8" Split Lock Washer

3/8"-16 Hex Nut

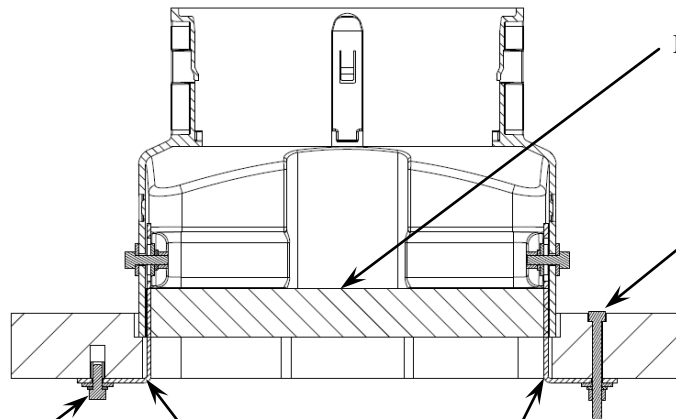

Moisture Barrier Placement
(not included with all vault base assemblies)

Hardware installation
shown for thru hole
mounting to lid

Hardware installation
shown for blind insert
hole mounting to lid

Mounting brackets attached
to inside of pedestal base
and underside of vault lid.