

Charles Universal Broadband Enclosures (CUBE) CUBE PM576 Series



PM576 Series Enclosures can serve a wide range of equipment such as power plants, routers, base band units, protection, site monitoring and fiber panels. With 38 RU of 19" rackmount space in both bays, these rugged enclosures feature a double-door design for technician-friendly access, and air conditioners for thermal management.

Specifications

Construction 0.125" Aluminum Welded Construction, Powder Coated Off White Finish
 Mounting Style Pad Mount
 Thermal Management 2K BTU AC (x1 or x2)
 Rack Mounting 19", 38RU in both bays, total of 76RU
 Door Latching 3-Point Latching with Pad Lockable Handles (Front and Rear)
 AC Termination 8 Position Load Center
 Certifications Telcordia GR-487-CORE, UL 60950

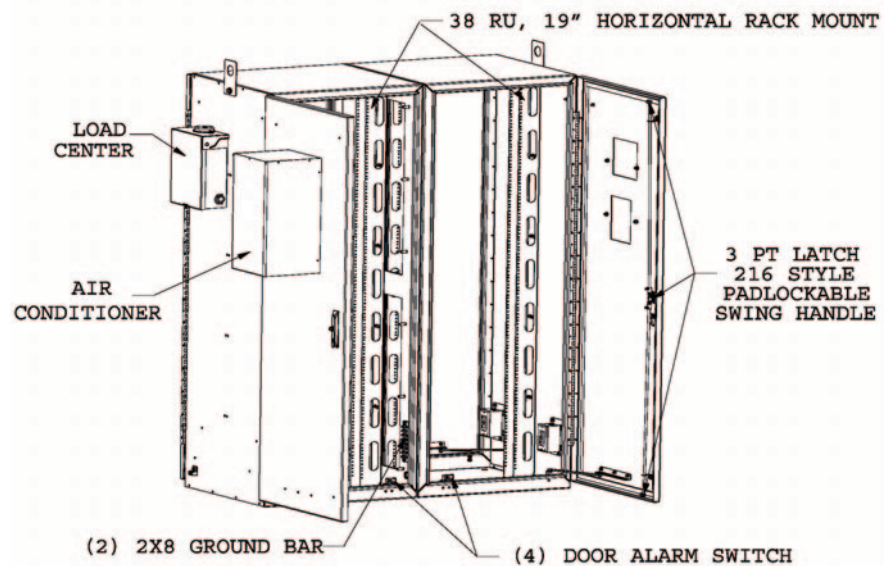

| Charles Part # | Overall Dimensions | RU | Mounting Rails | Equipment Chamber Door | Equip. Chamber Dim. (in) | Battery Chamber Dim. (in) | Handoff Chamber Dim. (in) | Load Center | Thermal Specs | Weight Empty |
|-----------------|--------------------|----------------------|----------------|------------------------|--------------------------|---------------------------|---------------------------|-------------|---------------|--------------|
| CUBE-PM57625EB1 | 72x50x26 | 38 per bay, 76 total | 19" Fixed Rail | Front & Rear | 72x50x26 | None | None | 8 position | 2K BTU AC | 360 |
| CUBE-PM57625EB3 | 72x50x26 | 38 per bay, 76 total | 19" Fixed Rail | Front & Rear | 72x50x26 | None | None | 8 position | (2) 2K BTU AC | 500 |

For additional product information, please visit www.charlesindustries.com

CUBE PM576 Series

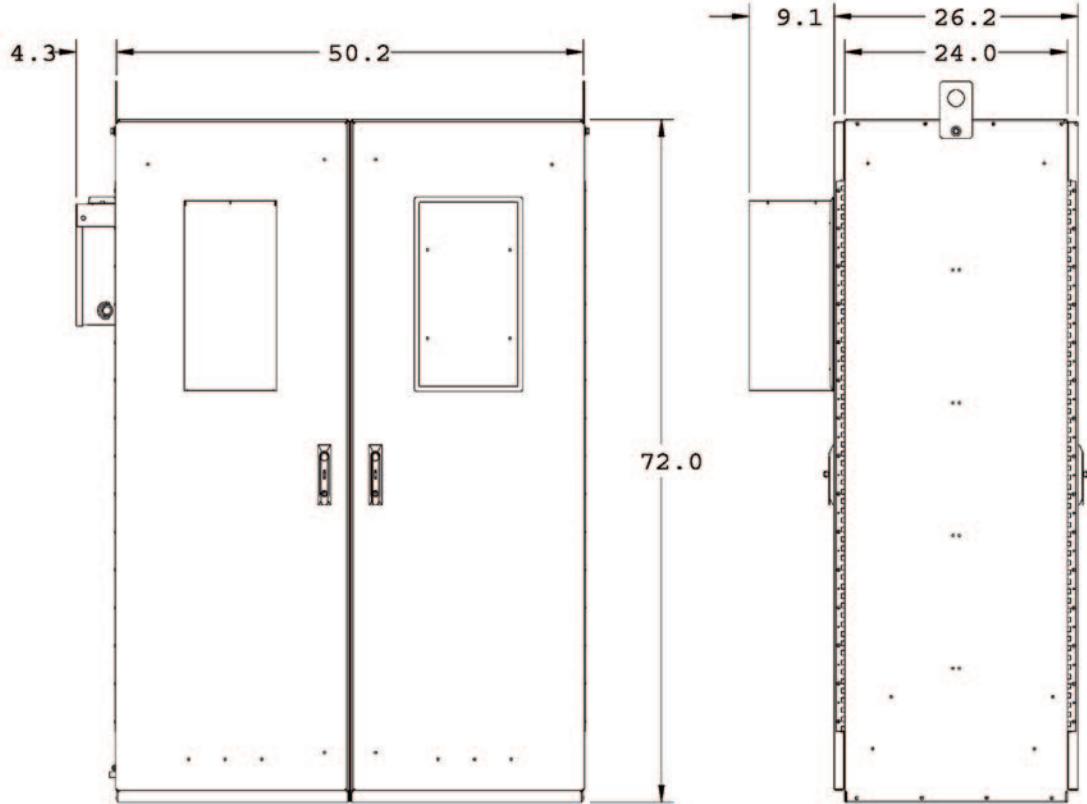

FRONT VIEW

SIDE VIEW

All measurements given in inches.

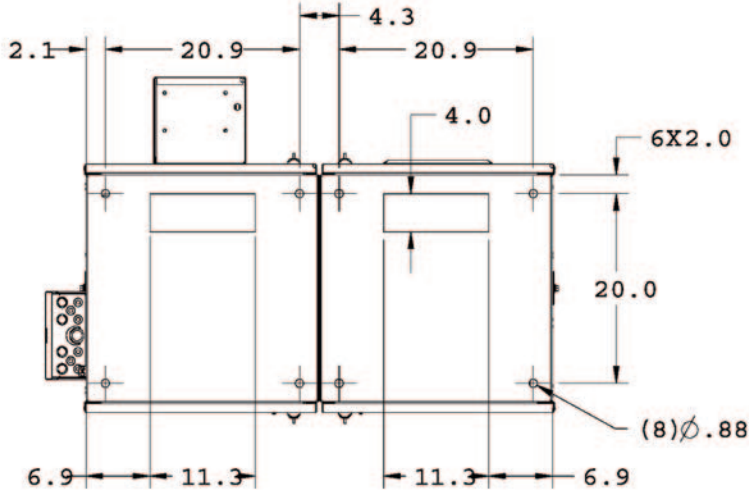

BOTTOM VIEW

